

**Fields and Waves I**  
**Homework 8**  
**Fall 2002**  
**Due: 5 December 2002**

**1. Short Questions (25 Points)** \_\_\_\_\_

**2. Multiple Choice (25 Points)** \_\_\_\_\_

**3. Boundary Conditions (25 Points)** \_\_\_\_\_

*Do One of the Following Two Problems:*

**4. Frequency Dependence (25 Points)** \_\_\_\_\_

**5. Laplace/Poisson (25 Points)** \_\_\_\_\_

*Do One of the Following Two Problems:*

**6. Electrostatics (25 Points)** \_\_\_\_\_

**7. Magnetostatics (25 Points)** \_\_\_\_\_

*Do One of the Following Two Problems:*

**8. Trans Lines – Pulses (25 Points)** \_\_\_\_\_

**9. Trans Lines – Sinusoidal (25 Points)** \_\_\_\_\_

*Do Both of the Following Two Problems:*

**10. Waves in Lossy Media (25 Points)** \_\_\_\_\_

**11. Waves – Oblique Incidence (25 Points)** \_\_\_\_\_

**Total (200 Points)** \_\_\_\_\_

Notes:

- 1) In the multiple choice section, each question may have more than one correct answer. Circle all of them.
- 2) For both the short questions and multiple choice questions, you may add some comments to justify your answer.
- 3) Make sure your calculator is set to perform trigonometric functions in radians, not degrees.



1. Short Questions

a. What is the charge density of a spherical shell at  $r = a$  and total charge  $Q$ . Assume a uniform distribution. (Include units)

b. What is the input impedance of a  $\frac{\lambda}{4}$  transmission line with a short circuit load?

c. What is the reflection coefficient of a matched transmission line and load?

d. What is the source impedance of the function generators we have used in class?

e. A conducting bar of length  $L$  aligned with the  $x$ -axis is moving through a uniform,  $z$  directed magnetic field  $\vec{B} = B_0 \hat{z}$  with a velocity  $\vec{v} = v_0 \hat{y}$ . What voltage is induced between the ends of the conducting bar?

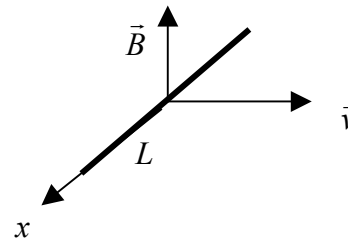

2. Multiple Choice Questions (Select all that are correct.)

- a. An  $N$  turn circular loop is placed in a sinusoidally varying magnetic field such that an  $EMF$  is measured. If we want to increase the  $EMF$ , we can
  - i. Increase the number of turns
  - ii. Increase the radius of the loop
  - iii. Lower the resistance of the wire used for the loop
  
- b. Which of the following is true of equipotentials:
  - i. They are parallel to electric fields lines
  - ii. A perfect conductor is an equipotential
  - iii. Equipotential surfaces are perpendicular to conducting surfaces
  
- c. The reluctance of a magnetic circuit:
  - i. Increases when the cross-sectional area perpendicular to  $B$  increases
  - ii. Increases when the path length of the  $B$  field increases
  - iii. Increases if an iron-iron contact is separated to form an air gap
  
- d. An air insulated coaxial cable has a total capacitance  $C$ . Assume that a hollow plastic pipe is slipped in between the two conductors and that the pipe does not fully fill the space.



- When the plastic pipe is placed partially inside the coaxial cable,
- i. The total capacitance of the cable becomes larger than  $C$
  - ii. There is at least a small force pulling the plastic pipe into the region between the conductors
  - iii. The maximum electric field in the air regions will be smaller with the plastic pipe inserted than without the plastic pipe inserted.
- e. Which of the following common devices involve concepts or technology connected with this course?
    - i. Credit cards
    - ii. Cell phones
    - iii. Xerography

## 3. Boundary Conditions

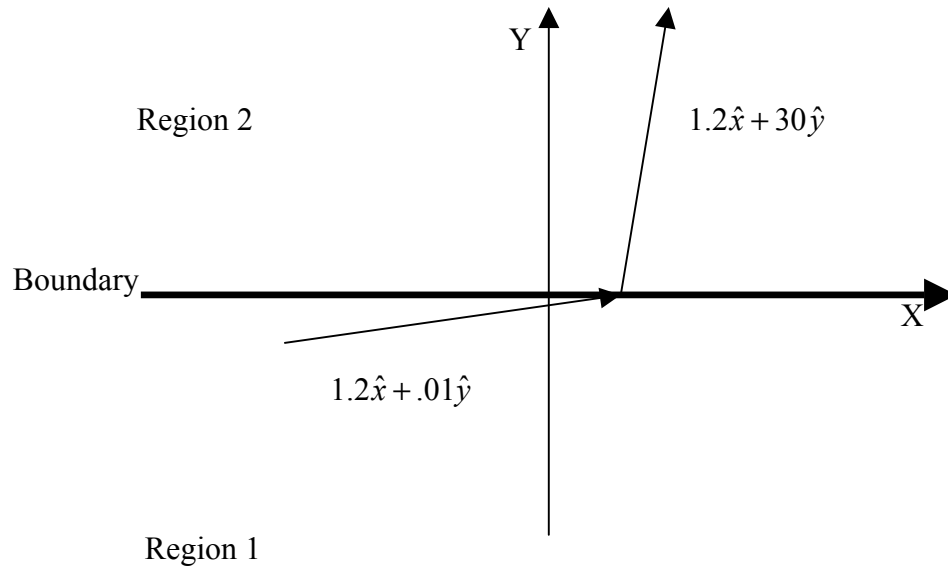

The figure represents one of two possible field lines and materials. It is either an electric field line across a dielectric-air boundary or a magnetic field line across a ferromagnetic-air boundary. Answer all the following questions.

a. If it is an  $\vec{E}$  field line, which region is air and what is the relative permittivity of the dielectric?

b. If it is an  $\vec{H}$  field line, which region is air and what is the relative permeability of the ferromagnetic material?

c. Given the materials we have worked with in class, which type of field line would you assume the figure represents? Why?

## 4. Frequency Dependence

As we have discussed many times, the characterization of a problem is often dependent on the frequency of operation. For each of the following problems, indicate which of the following frequencies are suitable.

Frequencies: 1 Hz 1 kHz 100 kHz 10MHz 1GHz  
Circle all correct answers in each case.

a. Silicon has a relative permittivity of 11.7 and a conductivity of  $4.4 \times 10^{-4}$ . At what frequencies can we consider the material to be a good insulator.

Frequencies: 1 Hz 1 kHz 100 kHz 10MHz 1GHz

b. We attach a load to a 1 [m] length of transmission line with a velocity rating of  $1.9 \times 10^8$  [m/s]. At what frequencies can we consider the line length to be a short (do not confuse this with a short circuit)? In other words, when will  $Z_{in} \approx Z_l$ ?

Frequencies: 1 Hz 1 kHz 100 kHz 10MHz 1GHz

c. If we construct a short circuit channel blocker such that the lowest frequency blocked is 1 MHz, what other frequencies will be blocked?

Frequencies: 1 Hz 1 kHz 100 kHz 10MHz 1GHz

d. The little holes in the screen on the door of a microwave oven block all frequencies up to and including the operating frequency of the oven. Which frequencies will be blocked?

Frequencies: 1 Hz 1 kHz 100 kHz 10MHz 1GHz

## 5. Laplace's and Poisson's equations

Using Laplace's or Poisson's equation, determine the voltage as function of position for a cylindrical capacitor (coaxial cable). The inner conductor is located at  $r = a$  and the outer conductor is located at  $r = b$ , where  $a < b$ . Charge only exists on surface of the conductors. Assume that the voltage on the inner conductor is  $V_o$  and the outer conductor is grounded. Be sure that you draw the figure before you attempt to solve for voltage. Also, you must demonstrate that your answer satisfies either Laplace's or Poisson's equation.

## 6. Electrostatics

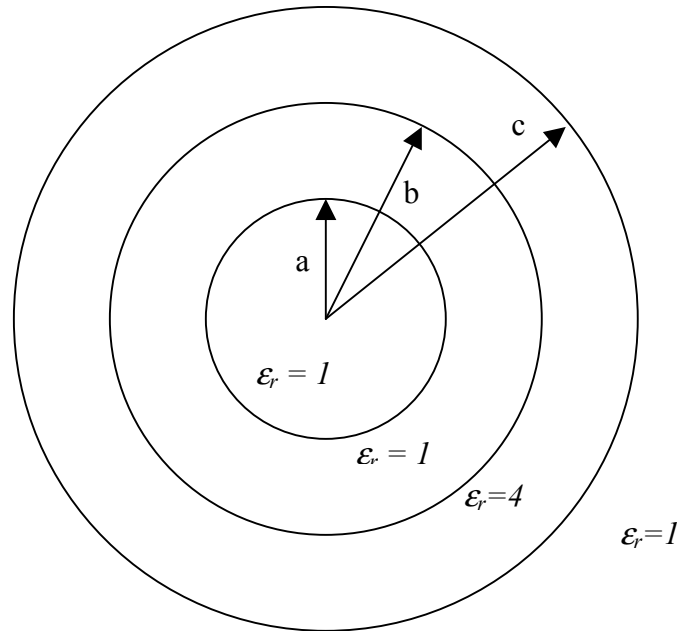

A cross-section of a cylindrical charge distribution is shown in the figure. A charge density exists in the region  $a < r < b$ , such that  $\rho = \frac{a\rho_0}{r}$  [ $C/m^3$ ]. Additionally, the charge distribution is enclosed by a dielectric cylindrical shell in the region  $b < r < c$ . For further clarification, the charge density ‘stops’ at the location  $r = b$  where the dielectric material ‘begins’. Also note that the region beyond the dielectric is free space.

a. Sketch the Gaussian surface you would apply to determine the electric field. Do your best to make a three-dimensional surface and indicate any surfaces where  $\vec{D} \cdot d\vec{S}$  is zero. EXPLAIN WHY.

**Fields and Waves I**

Name \_\_\_\_\_ **ECSE-2100** **Fall 2002** Section \_\_\_\_\_

b. Determine  $\vec{D}$  and  $\vec{E}$  everywhere. Include units and direction in your solution.

c. Verify your solution using the differential forms of Maxwell's equations in the region where charge exists.



7. Magnetostatics \_\_\_\_\_

A long solenoid that has a square cross-section with sides of length,  $a$ , and  $n$  turns/m is shown in the figure. The core is iron with  $\mu_r = 4000$ . The dashed line represents the current.

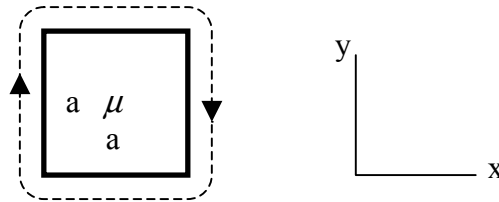

Cross-sectional View

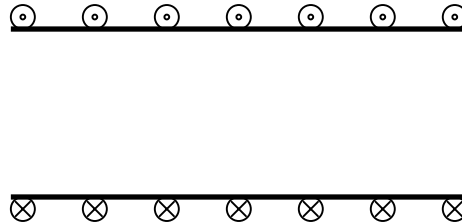

Side View

a. Sketch the surface you would use to apply Ampere's Law to this problem. Be careful in your drawing and make the loop that bounds the surface consistent with the integration path you would choose. Label the coordinate directions in your figure.

**Fields and Waves I**

Name \_\_\_\_\_ ECSE-2100 Fall 2002 Section \_\_\_\_\_

b. Determine  $\vec{B}$  and  $\vec{H}$  everywhere. Be sure to include units, direction and specify the regions that correspond to your solutions.

c. Determine the total flux linked inside the solenoid.

d. Determine the inductance of the solenoid.

e. Determine the energy stored in the solenoid.

8. Transmission Lines - Pulse Propagation

a. Two circuits are shown on this page. The following page has three plots, measuring the voltage at the location of the marker (the node between T1, T2, and T3). The source sends a 1V, 5ns pulse every 100ns, as indicated in the circuit diagrams. For each plot, identify the corresponding circuit. (There is, of course, one extra plot.) Additionally, for Circuit 1, add the plot across R4 on to the plot given. Each line has a propagation delay of 40ns and a characteristic impedance of 50  $\Omega$ .

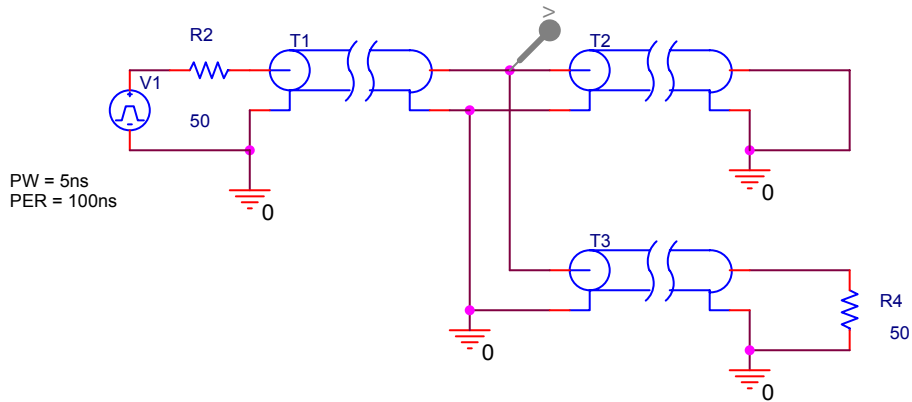

Circuit 1

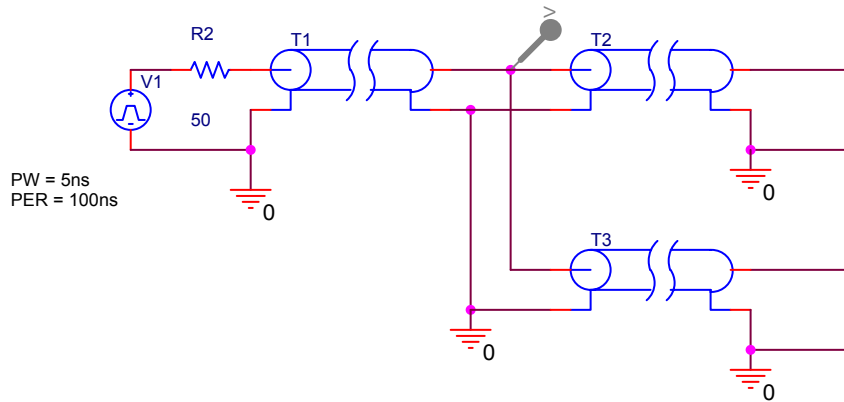

Circuit 2

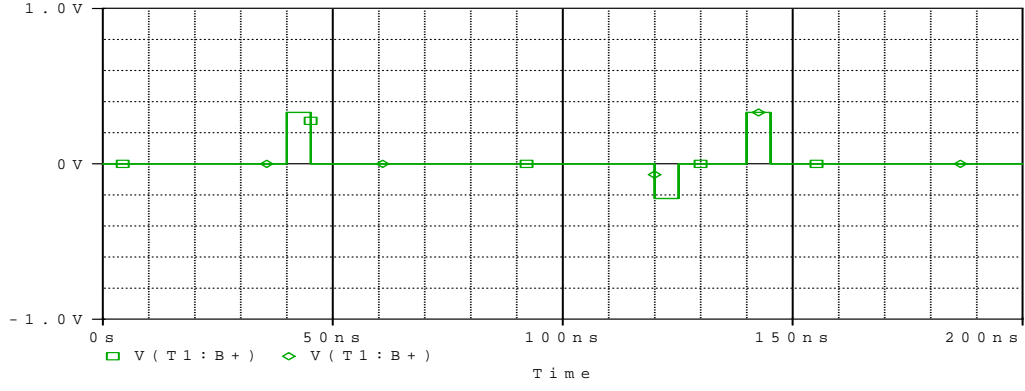
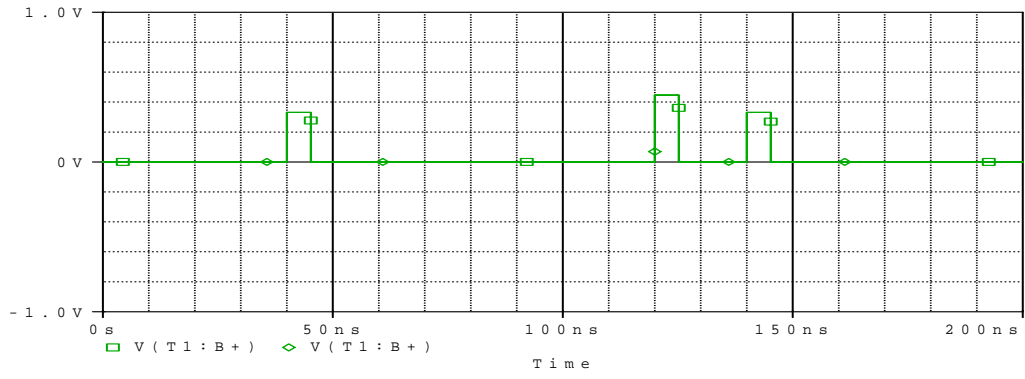
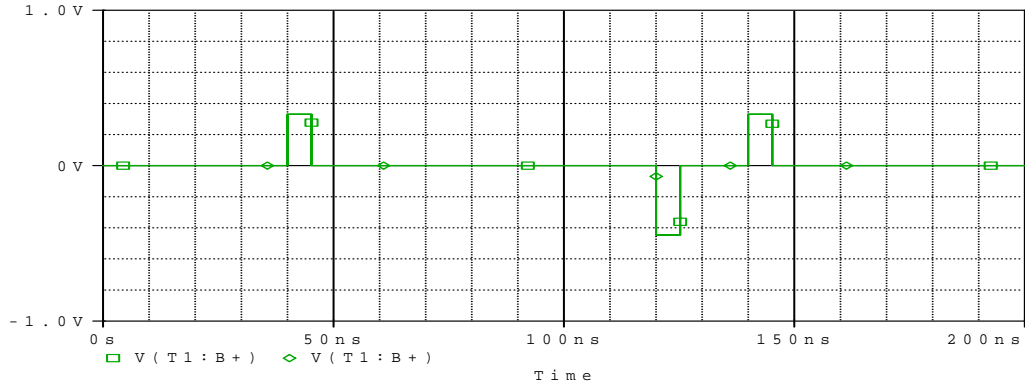

9. Transmission Lines – Sinusoidal Sources

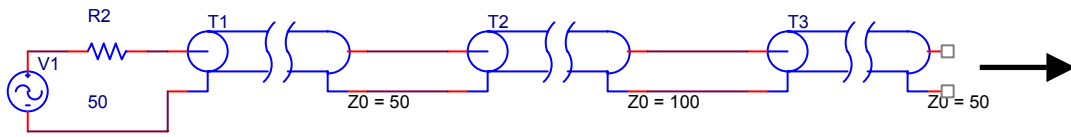

A 150 MHz source feeds into a transmission line network. Unfortunately, it was necessary to splice a short section of line (T2) to form a connection between the T1 and T3. Even more unfortunate for you, the cable available has a different characteristic impedance as shown on the bottom right of each section. Assuming all lines are filled with the same insulating material (polyethelene,  $\epsilon_r = 2.4$ ), determine the shortest (nonzero) length of line you can use to make the splice such that there are no reflections back toward the source. Assume T3 continues indefinitely so that you do not need to worry about how that line is terminated.

10. Waves in Lossy Media

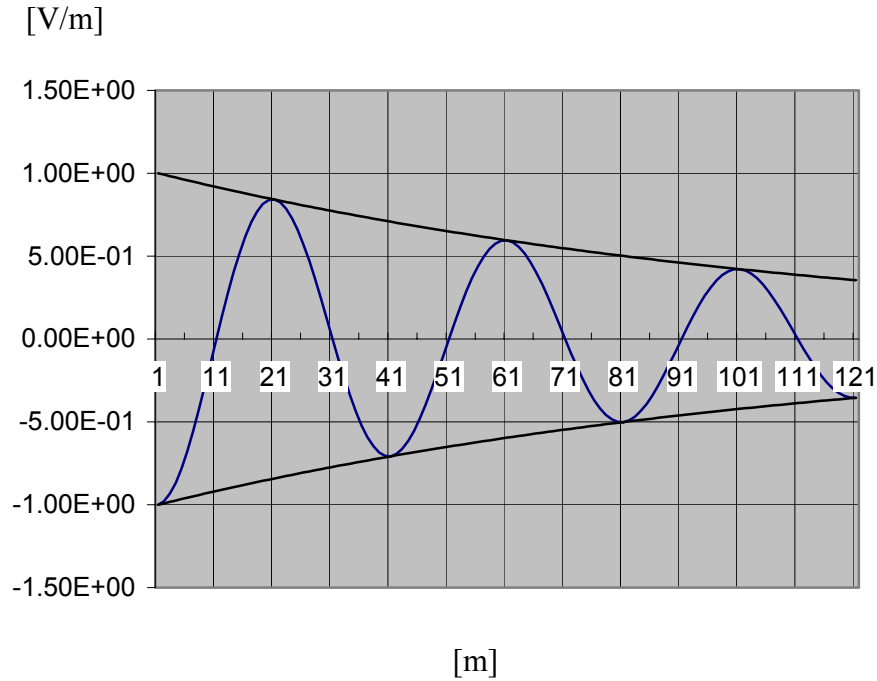

The figure is a plot of the Electric field plane wave magnitude in a lossy material with a frequency of 5 MHz. The plot is at the time,  $t = 0$  (this is important).

a. Determine the spatial frequency,  $\beta$ , the attenuation constant,  $\alpha$ , the amplitude of the wave, and the radial frequency,  $\omega$ .

b. The wave is propagating in the  $\hat{x}$  direction, and the electric field is  $z$  directed. Determine the electric field in phasor form.

11. Uniform Plane Waves – Oblique Incidence

A red laser beam ( $\lambda = 656\text{nm}$ ) is incident obliquely as shown from air on the inside of a corner reflector cut out of a dielectric material with  $\epsilon = 4\epsilon_0$ .

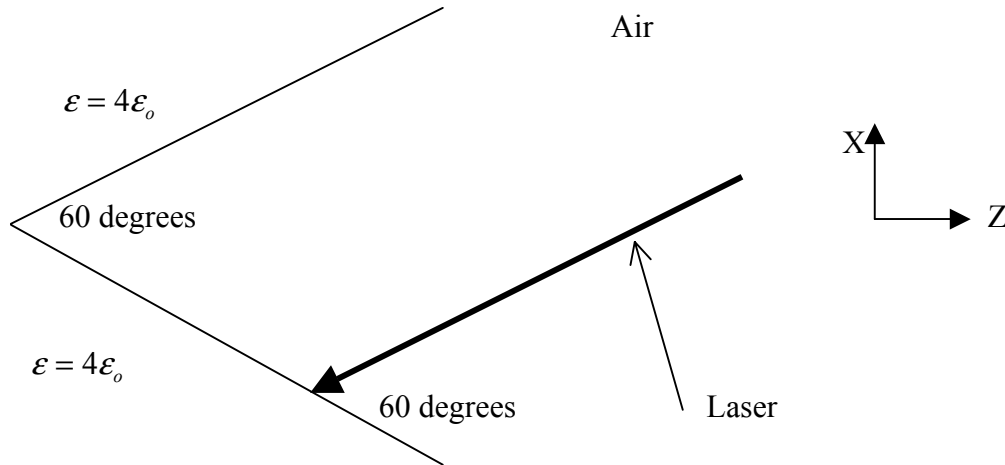

- The wave will reflect off of the first boundary, propagate to the second boundary and then reflect off of the second boundary. Show the complete path of the wave in the air region, labeling all of the angles.
- Determine the phasor form of the incident electric field if it is in the y-direction and has a magnitude of  $100\text{ V/m}$ .
- Determine the phasor form of the electric field after it has reflected both times.
- What percentage of the power is left after the second reflection?