

Lab 9. Light Sensitive Flash Camera

Overview of this Session

In this laboratory, you will learn:

- How to solder
- How to trigger a flash circuit in a disposable camera

Introduction

- This lab is designed to teach you how to trigger the flash in a disposable camera with a light detecting circuit. When operating properly, the flash should go off every 7 seconds for as long as no light is getting into the IR detector.

Background

In lecture you learned that a transformer could be used to take a small AC signal and create a large one, or vice-versa. The Flash camera uses this property to create a large rectified AC signal to charge a capacitor to 320 volts. The energy from this cap is used to ignite the gas in the Xenon flash. Xenon is normally a good insulator, however when it is charged separately by another high voltage field it starts to become more of a conductor which then allows the field around it to become greater, which in turn makes it even more of a conductor. This avalanche effect eventually brings the resistance down so low (to around 1 ohm) that the large capacitor that was holding 320V discharges and causes a bright light. After all the current has dissipated, the Xenon gas acts like an insulator again and the process can start over again.

The charge time for the capacitor is around 7 seconds, so a 555 timer will be used to trigger the flash every seven seconds.

WARNING: The TA's will show you how much energy the capacitor holds. **320 DC volts will not kill you, but it will hurt if it burns you.** Solder the circuit without the battery in place. Remember to discharge the circuit (the TA will show you how) before the TA helps you. The TA will also show you how to prevent accidental pain by insulating the camera with electrical tape after you do your soldering.

At the end of this lab, you may keep your camera and protoboard.

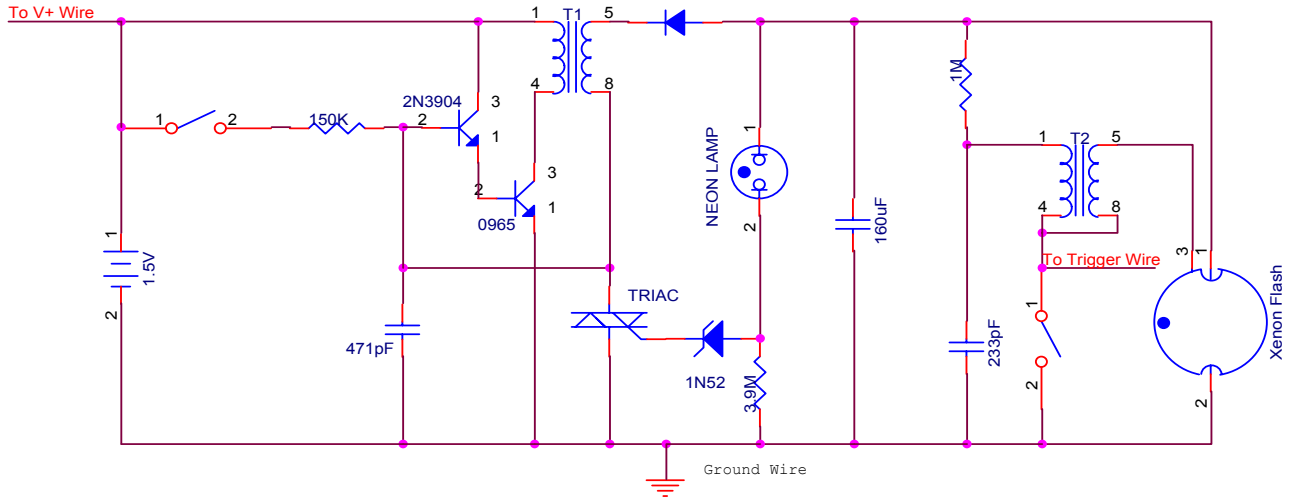
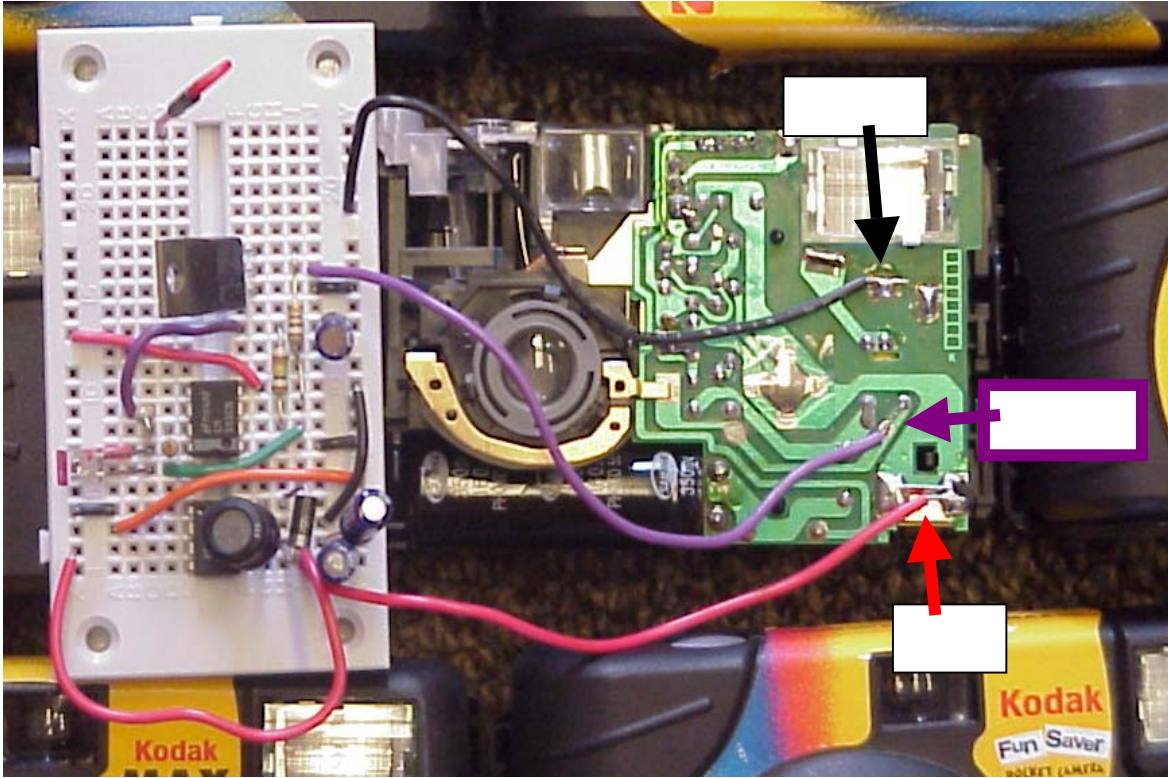

PART 1: Soldering wire to the camera

The photo above shows where you need to solder the wires. Please choose appropriate color for each wire. Make Red the V+ wire and Black the GND wire. This will avoid confusion. The trigger wire may be any color you wish.

A good solder joint is created by heating the parts you want to connect before applying the solder. Tin the iron tip before applying solder to the joint. Place the solder iron tip on both the pad on the circuit board and the wire end. Place solder near the soldering iron tip and the pad and wire. You should be making a

neat solder blob that covers the pad and the wire. Pull away the solder and the iron. Let it cool and test the connection by pulling on the wire lightly.

PART 2: The DC-DC converter

Build this circuit:

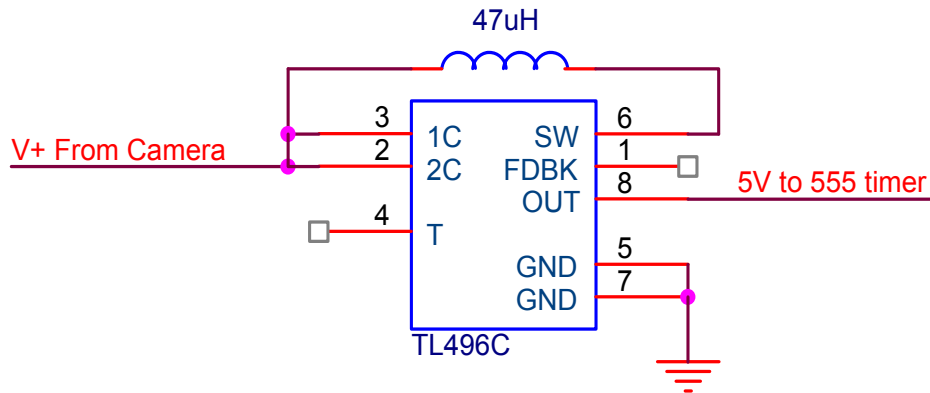

9.1 What is the voltage into this circuit (i.e. from the camera)?

9.2 What is the voltage the converter make when powered?

PART 3: The Trigger Circuit

Build this circuit:

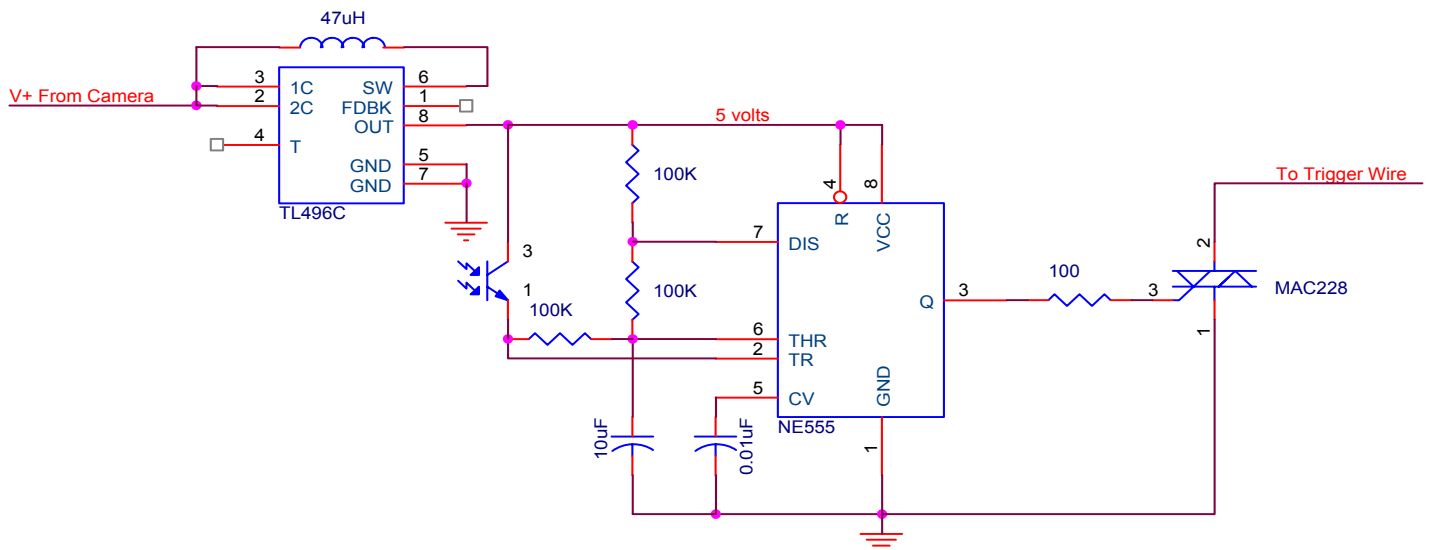

You should read the data sheet for the MAC228 triac for how to hook it up. Basically it is a high voltage switch. When a small current from the output of the 555 timer goes into the gate (pin 3) of the switch it allows through large AC voltages from MT1 to MT2 (pins 1 and 2). The trigger voltage is essentially a large change in voltage.

- 9.3 When the photo detector is not covered, why doesn't the circuit trigger a flash?
- 9.4 When the photo detector is covered, at what rate does the flash go off?

Data Sheets for New Components

TL496C, TL496Y 9-V POWER-SUPPLY CONTROLLERS

SLVS012B – AUGUST 1978 – REVISED AUGUST 1995

- Internal Step-Up Switching Regulator
- Fixed 9-V Output
- Charges Battery Source During Transformer-Coupled-Input Operation
- Minimum External Components Required (1 Inductor, 1 Capacitor, 1 Diode)
- 1- or 2-Cell-Input Operation

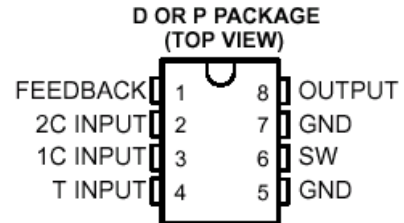

Terminals 5 and 7 are connected together internally.

description

The TL496C power-supply control circuit is designed to provide a 9-V regulated supply from a variety of input sources. Operable from a 1- or 2-cell battery input, the TL496C performs as a switching regulator with the addition of a single inductor and filter capacitor. When ac coupled with a step-down transformer, the TL496C operates as a series regulator to maintain the regulated output voltage and, with the addition of a single catch diode, time shares to recharge the input batteries.

The design of the TL496C allows minimal supply current drain during standby operation (125 μ A typical). With most battery sources, this allows a constant bias to be maintained on the power supply. This makes power instantly available to the system, thus eliminating power-up sequencing problems.

TL496C, TL496Y 9-VOLT POWER-SUPPLY CONTROLLERS

SLVS012B – AUGUST 1978 – REVISED AUGUST 1995

functional description

The TL496C is designed to operate from either a single-cell or two-cell battery source. To operate the device from a single cell (1.1 V to 1.5 V), the source must be connected to both inputs 1C INPUT and 2C INPUT as shown in Figure 1. For a two-cell operation (2.3 V to 3 V), the input is applied to 2C INPUT only and 1C INPUT is left open (see Figure 2).

battery operation

The TL496C operates as a switching regulator from a battery input. The cycle is initiated when a low-voltage condition is sensed by the internal feedback (the thresholds at terminals 1 and 8 are approximately 7.2 and 8.6 V respectively). An internal latch is set and the output transistor is turned on. This causes the current in the external inductor (L) to increase linearly until it reaches a peak value of approximately 1 A. When the peak current is sensed, the internal latch is reset and the output transistor is turned off. The energy developed in the inductor is then delivered to the output storage capacitor through the blocking diode. The latch remains in the off state until the feedback signal indicates the output voltage is again deficient.

MAC228A Series

Preferred Device

Sensitive Gate Triacs

Silicon Bidirectional Thyristors

Designed primarily for industrial and consumer applications for full wave control of ac loads such as appliance controls, heater controls, motor controls, and other power switching applications.

- Sensitive Gate Triggering in 3 Modes for AC Triggering on Sinking Current Sources
- Four Mode Triggering for Drive Circuits that Source Current
- All Diffused and Glass–Passivated Junctions for Parameter Uniformity and Stability
- Small, Rugged, Thermowatt Construction for Low Thermal Resistance and High Heat Dissipation
- Center Gate Geometry for Uniform Current Spreading
- Device Marking: Logo, Device Type, e.g., MAC228A4, Date Code

TRIACS
8 AMPERES RMS
200 thru 800 VOLTS

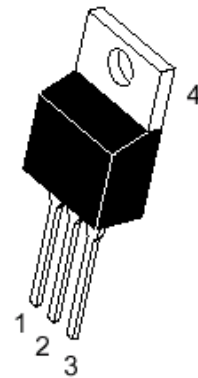

TO-220AB
CASE 221A
STYLE 4

PIN ASSIGNMENT	
1	Main Terminal 1
2	Main Terminal 2
3	Gate
4	Main Terminal 2

PACKAGE DIMENSIONS

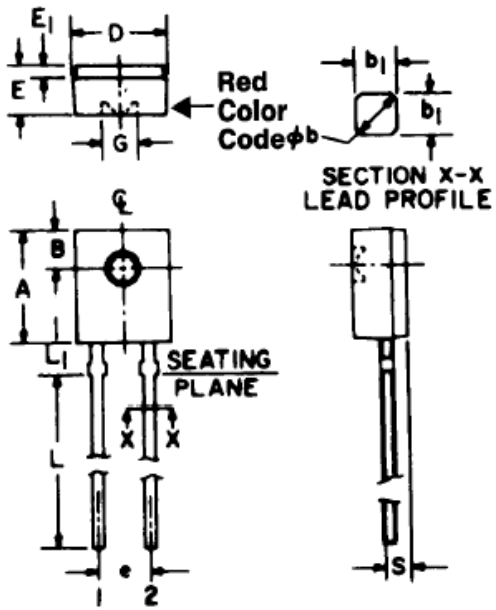

DESCRIPTION

The L14Q1 is a silicon phototransistor encapsulated in a clear, wide angle, sidelooper package.

FEATURES

- Good optical to mechanical alignment
- Mechanically and wavelength matched to the F5F LED
- Plastic package with a color stripe for easy recognition from LED

ST1335

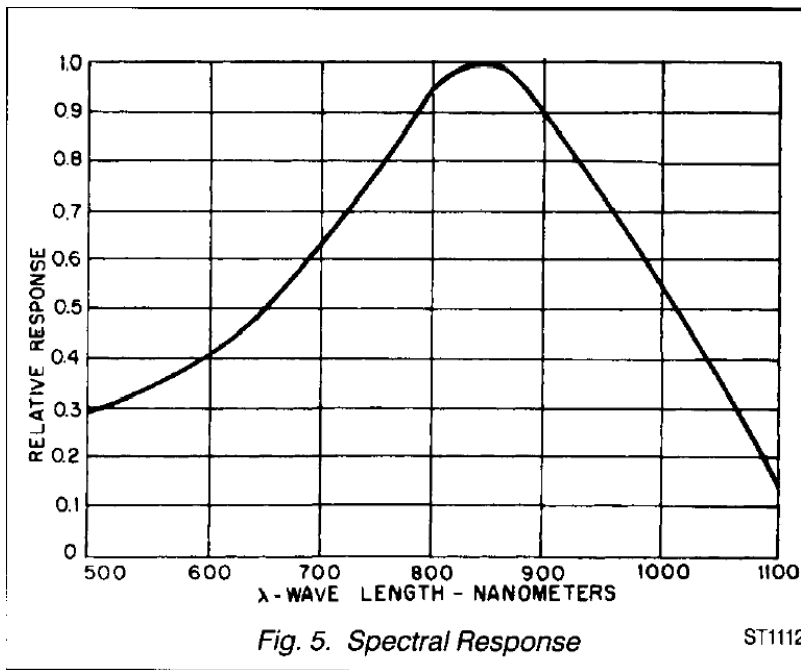
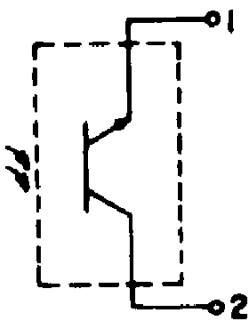

Fig. 5. Spectral Response

ST1112

