

Agilent PNA Series Microwave Network Analyzers

Configuration Guide

PNA-X N5241A	10 MHz to 13.5 GHz
PNA-X N5242A	10 MHz to 26.5 GHz
PNA-X N5244A	10 MHz to 43.5 GHz
PNA-X N5245A	10 MHz to 50 GHz
PNA E8362C	10 MHz to 20 GHz
PNA E8363C	10 MHz to 40 GHz
PNA E8364C	10 MHz to 50 GHz
PNA E8361C	10 MHz to 67 GHz
PNA N5250C	10 MHz to 110 GHz
PNA-L N5230C	300 kHz to 6, 13.5, or 20 GHz, 10 MHz to 20, 40, or 50 GHz

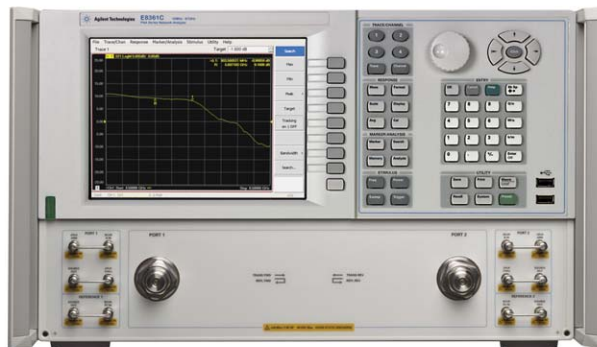
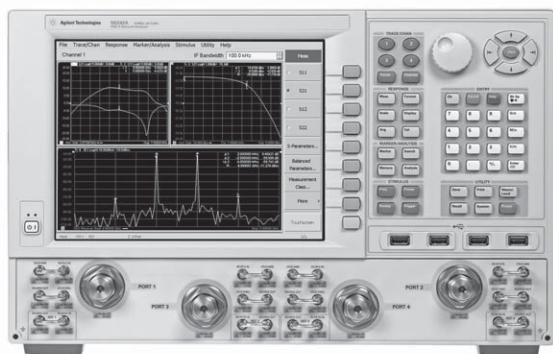

This configuration guide describes standard configurations, options, accessories, upgrade kits and compatible peripherals for the PNA Series microwave network analyzers. This guide should be used with the *Agilent PNA Series Microwave Network Analyzers Data Sheet* for a complete description of these analyzers.



Table of Contents

PNA-X Series Network Analyzer	4
Option configurations	4, 5
Test set and power configuration options	6, 7
Measurement applications	8
Nonlinear vector network analysis	9
Pulse, antenna, millimeter-wave	9
Accessories	9
Upgrade kits	10, 11
PNA Series Network Analyzer	12
Option configurations	12
Test set and power configuration options	13
Measurement applications	13
Pulse, antenna, millimeter-wave	14
Accessories	14
Configuration details	14
Simplified test set block diagrams	15-19
N5250C millimeter-wave system	20, 21
Upgrade kits	22
PNA-L Series Network Analyzer	23
Option configurations	23
Test set and power configuration options	24
Measurement applications	25
Upgrade kits	26
Measurement Accessories	27
Calibration kits, cables, adapters	27
For devices with 1.0 mm connectors	28
For devices with 1.85 mm connectors	28
For devices with 2.4 mm connectors	29
For devices with K (2.92 mm) connectors	29
For devices with 3.5 mm or SMA connectors	31, 32
For devices with Type-N connectors	32
For devices with 7 mm connectors	33
For devices with waveguide	33, 34
Verification kits	34
General Accessories	35
USB	36
Hard drive	35
Probe	35
Power meters and sensors	35
Amplifiers	35
Couplers	35
Equipment rack accessories	35
Monitors	35
Printers	35
Interface cables	35
Applications	36

Agilent offers the following options for all PNA family network analyzers

Certification options

Commercial calibration certification with test data (Option UK6)

Complete set of measurements which tests unit to manufacturer's published specifications. Includes calibration label, calibration certificate, and data report. Conforms to ISO 9001.

ISO 17025 compliant calibration (Option 1A7)

Complete set of measurements which tests unit to manufacturer's published specifications. Includes calibration label, ISO 17025 calibration certificate, and data report, measurement uncertainties and guardbands on all customer specifications. Conforms to ISO 17025 and ISO 9001.

ANSI Z540 compliant calibration (Option A6J)

Complete set of measurements which tests unit to manufacturer's published specifications. Includes pre- and post-adjustment data with measurement uncertainty information compliant to the ANSI/NCSL Z540 standard.

Warranty and service

1-, 3-, and 5-year warranty and service plans are available at the time of instrument purchase. Standard warranty is 1 year.

Documentation

The PNA Series instruments are equipped with an Online Help system available within the instrument in the following languages: English, Japanese, Chinese, German, Spanish, and French. Service guides and the Online Help system are available on the web: www.na.tm.agilent.com/pna

Calibration Software Licenses

Perpetual license for built-in performance test software for Agilent inclusive cal (Option 897)

Adds built-in performance testing and calibration software for self-maintainers. Requires additional equipment. See the analyzer's Service Guide for more information on equipment required.

Perpetual license for built-in performance test software for Standards compliant cal (Option 898)

Adds built-in performance testing and calibration software for self-maintainers. Requires additional equipment. See the analyzer's Service Guide for more information on equipment required.

PNA-X Series Network Analyzer

N5241A	10 MHz to 13.5 GHz
N5242A	10 MHz to 26.5 GHz
N5244A	10 MHz to 43.5 GHz
N5245A	10 MHz to 50 GHz

Option configurations

To add options to a product, order the corresponding item number.

	Description	For N5241A	For N5242A	For N5244A	For N5245A	Additional information
Test set						
Option 200	2-ports, single source	N5241A-200	N5242A-200	N5244A-200	N5245A-200	
Option 224	2-ports, add internal 2nd source, combiner and mechanical switches	N5241A-224	N5242A-224	N5244A-224	N5245A-224	Requires Options 200, 219 and 080
Option 400	4-ports, dual source	N5241A-400	N5242A-400	N5244A-400	N5245A-400	Option 080 recommended
Option 423	4-ports, add internal combiner and mechanical switches	N5241A-423	N5242A-423	N5244A-423	N5245A-423	Requires Options 400, 419 and 080
Power configuration						
Option 219	2-ports, extended power range and bias-tees	N5241A-219	N5242A-219	N5244A-219	N5245A-219	Requires Option 200
Option 285 ^{1,2}	2-ports, extended power range, high-power configuration (no bias-tees)	N5241AS-285 ¹	N5242AH85-285 ²	N5244AS-285 ¹	N5245AS-285 ¹	Requires Option 200
Option 419 and bias-tees	4-ports, extended power range	N5241A-419	N5242A-419	N5244A-419	N5245A-419	Requires Option 400, Option 080 recommended
Option 485 ^{1,2}	4-ports, extended power range, high-power configuration (no bias-tees)	N5241AS-485 ¹	N5242AH85-485 ²	N5244AS-485 ¹	N5245AS-485 ¹	Requires Option 400, Option 080 recommended
Measurement applications						
Option 010	Time-domain measurements	N5241A-010	N5242A-010	N5244A-010	N5245A-010	
Option 029 ³	Fully-corrected noise figure measurements,	N5241A-029	N5242A-029	n/a	n/a	Requires one of Options 219, 224, 285, 419, 423, or 485, and Option 080
Option 080	Frequency offset	N5241A-080	N5242A-080	N5244A-080	N5245A-080	
Option 082 ⁴	Scalar-calibrated converter measurements	N5241A-082	N5242A-082	N5244A-082	N5245A-082	Requires Option 080
Option 083 ⁴	Vector- and scalar-calibrated converter measurements	N5241A-083	N5242A-083	N5244A-083	N5245A-083	Requires Option 080
Option 084	Embedded LO measurements	N5241A-084	N5242A-084	N5244A-084	N5245A-084	Requires at least one of Options 029, 082, 083, or 087
Option 086	Gain compression application	N5241A-086	N5242A-086	N5244A-086	N5245A-086	Options 219 or 419 recommended
Option 087	Intermodulation distortion application	N5241A-087	N5242A-087	N5244A-087	N5245A-087	Requires Options 224 or 423
Option 460	Integrated true-mode stimulus application	N5241A-460	N5242A-460	N5244A-460	N5245A-460	Requires Option 400
Option 551 ⁵	N-port capabilities	N5241A-551	N5242A-551	N5244A-551	N5245A-551	
Nonlinear vector network analysis						
Option 510	Nonlinear component characterization	N5241A-510	N5242A-510	N5244A-510	N5245A-510	Requires Options 419 and 080
Option 514	Nonlinear X-parameters ⁶	N5241A-514	N5242A-514	N5244A-514	N5245A-514	Requires Options 423 and 510
Option 518	Nonlinear pulse envelope domain	N5241A-518	N5242A-518	N5244A-518	N5245A-518	Requires Options 021 or 036, 025 and either one of 510 or 514
Option 520	Arbitrary load-impedance X-parameters	N5241A-520	N5242A-520	N5244A-520	N5245A-520	Requires Option 514

Required NVNA accessories

- U9391C 10 MHz to 26.5 GHz or U9391F 10 MHz to 50 GHz comb generator (two required for nonlinear measurements)
- Agilent power meter and sensor or USB power sensor
- Agilent calibration kit, mechanical or ECal
- Agilent signal generator, MXG or PSG used for X-parameter extraction (internal 10 MHz reference output can be used for 10 MHz tone spacing applications)

1. For N5241A/4A/5A, order special model N524xAS instead of N524xA and add Options H85 and 285 for 2-port, or Options H85 and 485 for 4-port. Order N524xA-xxx items for other standard options. Options 285 and 485 high-power test set modify the extended power range and bias-tees (Option 219 and 419), and therefore, they can not be ordered together.
2. Order special model N5242AH85 instead of N5242A and add Option 285 for 2-port or 485 for 4-port. Order N5242A-xxx items for other standard options. Options 285 and 485 high-power test set modify the extended power range and bias-tees (Options 219 and 419), and therefore, they can not be ordered together.
3. In addition to the list of required PNA-X options, Option 029 requires an N4691B ECal module for use as an impedance tuner, and an Agilent 346 series noise source for calibration.
4. Option 082 is a subset of Option 083; therefore, they cannot be ordered together.
5. When configured as a multipoint analyzer using Option 551, the combiner feature of Option 224 or 423 is temporarily disabled. When configured as a standalone analyzer, the combiner feature is enabled.
6. X-parameters is a trademark of Agilent Technologies

PNA-X Series Network Analyzer

Option configurations (continued)

To add options to a product, order the corresponding item number.

	Description	For N5241A	For N5242A	For N5244A	For N5245A	Additional information
Pulse, antenna, mm-wave						
Option H08	Pulse measurements	N5241A-H08	N5242A-H08	N5244A-H08	N5245A-H08	Requires Option 025
Option 020	Add IF inputs for antenna and mm-wave	N5241A-020	N5242A-020	N5244A-020	N5245A-020	
Option 021	Add pulse modulator to internal 1st source	N5241A-021	N5242A-021	N5244A-021	N5245A-021	
Option 022	Add pulse modulator to internal 2nd source	N5241A-022	N5242A-022	N5244A-022	N5245A-022	Requires Option 224 or 400
Option 025	Add four internal pulse generators	N5241A-025	N5242A-025	N5244A-025	N5245A-025	
Option 036 ¹	Add wide-pulse modulator to internal 1st source	n/a	n/a	N5244A-036	N5245A-036	
Option 037 ²	Add wide-pulse modulator to internal 2nd source	n/a	n/a	N5244A-037	N5245A-037	Requires Option 224 or 400
Option 118	Fast CW sweep	N5241A-118	N5242A-118	N5244A-118	N5245A-118	
Accessories						
Option 1CM	Rack mount kit for use without handles	N5241A-1CM	N5242A-1CM	N5244A-1CM	N5245A-1CM	
N1966A	Pulse I/O adapter	N1966A	N1966A	N1966A	N1966A	
N4688A	USB CD R/W drive	N4688A	N4688A	N4688A	N4688A	
N4689A	USB Hub	N4689A	N4689A	N4689A	N4689A	
Calibration software						
Option 897 ³	Perpetual license for built-in performance test software for Agilent inclusive calibration	N5241A-897	N5242A-897	N5244A-897	N5245A-897	
Option 898 ³	Perpetual license for built-in performance test software for standards compliant calibration	N5241A-898	N5242A-898	N5244A-898	N5245A-898	
Calibration documentation						
Option 1A7	ISO 17025 compliant calibration	N5241A-1A7	N5242A-1A7	N5244A-1A7	N5245A-1A7	
Option UK6	Commercial calibration certificate with test data	N5241A-UK6	N5242A-UK6	N5244A-UK6	N5245A-UK6	
Option A6J	ANSI Z540 compliant calibration	N5241A-A6J	N5242A-A6J	N5244A-A6J	N5245A-A6J	

1. Option 036 limits the minimum pulse-modulation width at 150 nsec and can not be ordered with Option 021.

2. Option 037 limits the minimum pulse-modulation width at 150 nsec and can not be ordered with Option 022.

3. Additional hardware required. Please refer to the analyzer's Service Guide for required service test equipment.

PNA-X Series Network Analyzer

The PNA-X is an integrated vector network analyzer featuring a built-in S-parameter test set, one or two synthesized sources used for device stimulus, a hard disk drive, USB interfaces, and a 10.4" LCD touch screen display. The N5241A and the N5242A have 50 ohm, ruggedized 3.5 mm (m) test ports. The N5244A and the N5245A have 50 ohm, ruggedized 2.4 mm (m) test ports. Included with each instrument is a mouse, keyboard (U.S. style), and a 1-year return-to-Agililent service warranty.

Test set and power configuration options

• 2-port standard test set and power range (Option 200)

The standard 2-port test set comes with six front-panel access loops. The loops provide access to the signal path between (a) the source output and the reference receiver, (b) the source output and directional coupler thru arm and (c) the coupled arm of the directional coupler and the port receiver. The standard test set also includes a solid-state internal RF transfer switch in the R1 reference-receiver path.

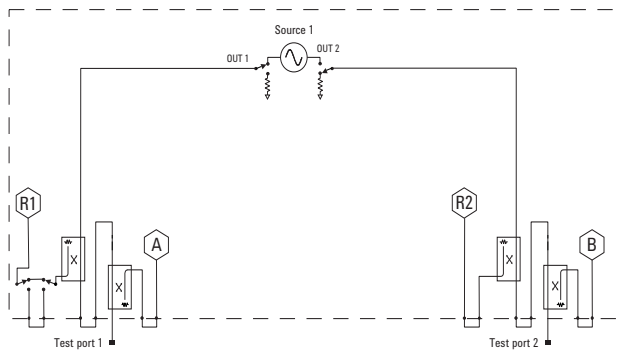

• Extended power range and bias-tees (Option 219, 419)

Adds to the standard test set one 65 dB source attenuator (settable in 5 dB increments), one 35 dB receiver attenuator (settable in 5 dB increments), and one bias-tee to each test port. Option 219 requires Option 200, and Option 419 requires Option 400.

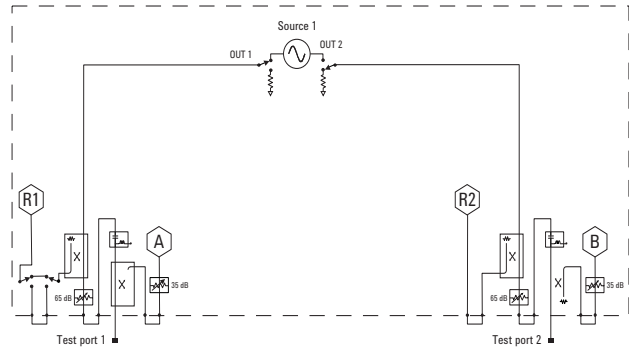

(Option 219, requires Option 200)

• 4-port standard test set, power range and an internal second source (Option 400)

The standard 4-port test set comes with 12 front-panel access loops and a built-in second source. The loops provide access to the signal path between (a) the source output and the reference receiver, (b) the source output and directional coupler thru arm and (c) the coupled arm of the directional coupler and the port receiver. The internal second source provides an additional signal (fixed or swept) for two-tone third-order-intercept (TOI) and intermodulation testing of amplifiers, or it can be used as a fast swept-LO signal for fixed-IF testing of mixers and converters. With two sources, source 1 is accessible through test ports 1 and 2, and source 2 is accessible through test ports 3 and 4. The standard test set also includes a solid-state internal RF transfer switch in the R1 reference-receiver path. Recommends Option 080.

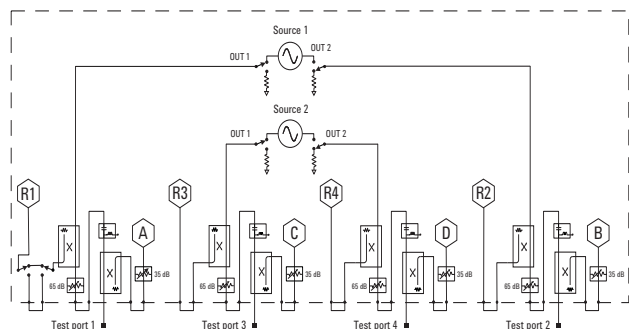

(Option 419, requires Option 400)

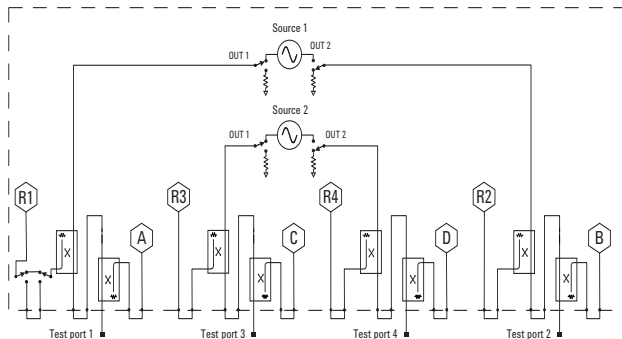

PNA-X Series Network Analyzer

- **Add an internal second source, a combiner and mechanical switches to 2-port analyzer (Option 224)**

Available with 2-port model only, this option adds an internal second source, a combiner and mechanical switches. The internal second source provides an additional signal (fixed or swept) for two-tone third-order-intercept (TOI) and intermodulation testing of amplifiers, or it can be used as a fast swept-LO signal for fixed-IF testing of mixers and converters. The mechanical switches provide increased flexibility by having rear panel access to signal paths for advanced applications. Access to the second source is available through two output (SMA) connectors on the front panel. Requires Options 200, 219 and 080.

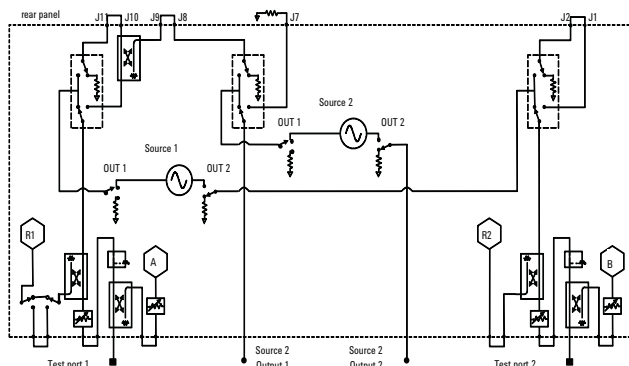

- **Add an internal combiner and mechanical switches to 4-port analyzer (Option 423)**

Available with 4-port model only, this option adds a combiner and mechanical switches. The mechanical switches provide increased flexibility by having rear panel access to signal paths for advanced applications. Requires Options 400, 419 and 080.

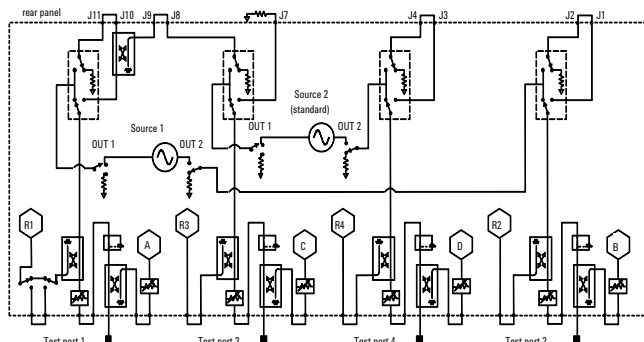

- **High-power test set (Model N5241AS/N5242AH85/N5244AS/N5245AS Option 285, 485)**

With extended power range and bias-tees (Option 219, 419), the internal bias tees limit the maximum test port input power to +30 dBm. The high-power test set removes the bias tees between the source attenuators and the test port couplers. This extends the maximum port power that the analyzer can safely handle to +43 dBm. The high-power test set modifies Options 219 and 419, and therefore, they can not be ordered together.

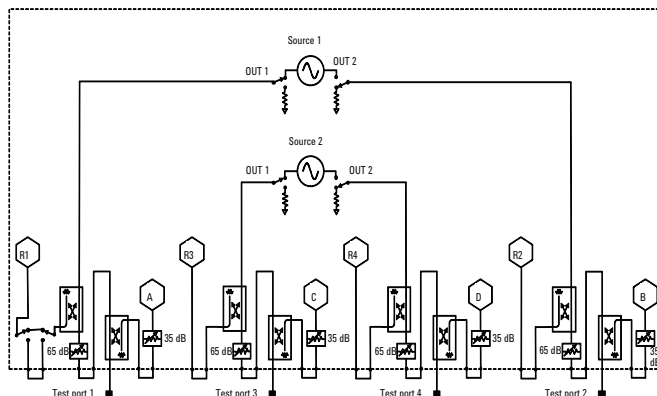

PNA-X Series Network Analyzer

Measurement applications

Time domain (Option 010)

This option enables the PNA-X to view reflection and transmission responses in time or distance. Use time domain to tune filters, gate out the response of fixtures and cables, characterize the impedance of transmission lines and more.

Fully-corrected noise figure measurements (Option 029)

This option adds hardware and firmware for high-accuracy noise figure measurements of both amplifiers and frequency converters, utilizing Agilent's unique source-correction technique. For full correction, the PNA-X and an Agilent ECal module configured as an impedance tuner are used to remove the effects of imperfect system source match, greatly improving the accuracy of the cold-source technique. This approach surpasses the accuracy provided by the Y-factor method. This option requires an N4691B ECal module (m-f recommended) and a 346-series noise source (both must be ordered or supplied separately). During calibration of the analyzer, an additional ECal or mechanical calibration kit is required (also must be ordered or supplied separately). The noise source is only used during calibration of the analyzer. To use the ECal module as a tuner, Option 029 includes a cable (N5242-20137) and 3.5 mm m-f adapter (85052-60013) for use with m-f modules (N4691B-M0F). For use with f-f ECal modules (N4691B-00F), order a 3.5 mm m-m adapter (85052-60014). A scalar calibration choice is also available that offers less accuracy, but is faster and does not require the ECal module used as an impedance tuner.

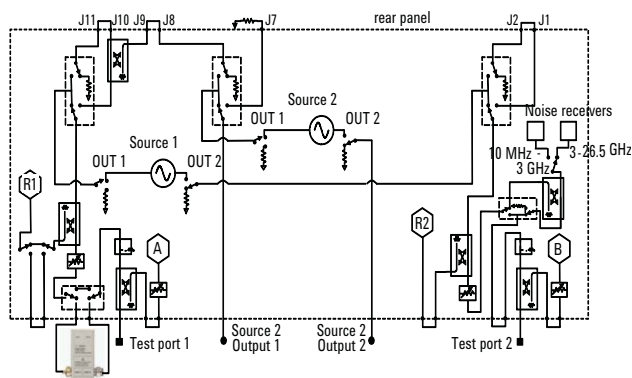

Frequency offset (Option 080)

This option enables the PNA-X to set the source frequency independently from where the receivers are tuned. This ability is important for measuring amplifiers, mixers, and frequency converters.

Scalar-calibrated converter measurements (Option 082)

With a simple setup and calibration, this application delivers the highest accuracy for conversion-loss (or gain) magnitude measurements by combining one-port and power-meter calibrations to remove mismatch errors. This application provides an intuitive and easy-to-use user interface for setting up mixer and converter measurements, with single or dual conversion stages (up to two local oscillators, LO), along with control of up to two external signal generators for use as LO. External synthesizers supported include the Agilent ESG series and the PSG series of signal source families as well as other SCPI controlled signal generators. Option 082 requires Option 080, and cannot be ordered with Option 083.

Vector- and scalar-calibrated converter measurements (Option 083)

This converter measurement is a superset and includes not only the scalar-calibrated converter measurement, but also the vector-mixer calibration (VMC). The advanced and unique VMC delivers exceptional conversion loss amplitude and phase accuracy for mixer and converter measurements. This application provides an intuitive and easy-to-use user interface for setting up mixer and converter measurements, with single or dual conversion stages (up to two LO's), along with control of up to two external signal generators for use as LO. External synthesizers supported include the Agilent ESG series and the PSG series of signal source families as well as other SCPI controlled signal generators. Option 083 requires Option 080, and cannot be ordered with Option 082.

Embedded LO measurements (Option 084)

This option tunes the PNA-X receivers to the output frequency of the converter under test, without the need for access to internal LOs or a common reference signal. For converters with embedded LOs, this option enables measurements of match-corrected conversion loss/gain (requires Option 082 or 083), absolute group delay (requires Option 083), intermodulation distortion (requires Option 087), and noise figure (requires Option 029).

Gain compression application (Option 086)

The Gain Compression Application (GCA) provides input power, output power, gain, and phase at an amplifier's compression point, over a specified frequency and power range. GCA's SMART Sweep is very fast and easy-to-use. GCA also includes a guided calibration that corrects for absolute power levels, frequency response, and mismatch errors. Requires firmware A.08.00 and above.

Intermodulation distortion application (Option 087)

The intermodulation distortion (IMD) application makes it very easy to set up and calibrate swept-IMD measurements of both amplifiers and frequency converters. It uses the built-in second source and internal combiner of the PNA-X (requires Option 224 or 423). The user can sweep either the center frequency of the two stimulus signals, the frequency spacing of the two stimulus signals about a fixed center frequency, or the power of one or both stimulus signals or the power of the LO signal. The analyzer can measure intermodulation distortion products of order 2, 3, 5, 7, or 9, and can display the associated intercept points. In addition, an IM Spectrum mode gives a spectrum-analyzer-like display for confirming or trouble-shooting measurements. Requires firmware A.08.33 and above.

Integrated true-mode stimulus application (Option 460)

Integrated true-mode stimulus application (iTMSA) provides mismatch-corrected true-mode (true differential and true common) stimulus and enables accurate balanced measurements under real operating conditions. iTMSA also provides balanced measurements with forward-only sweep, reverse-only sweep, and frequency or power sweep with arbitrary phase and amplitude offsets. Requires firmware A.08.20 and above.

N-port capabilities (Option 551)¹

Adds full N-port error correction and measurement capabilities to the PNA-X network analyzer. External test set is required.

1. When configured as a multiport analyzer using Option 551, the combiner feature of Option 224 or 423 is temporarily disabled. When configured as a standalone analyzer, the combiner feature is enabled.

PNA-X Series Network Analyzer

Nonlinear vector network analysis

Please refer to the Nonlinear Vector Network Analyzer brochure for more information 5989-8575EN

Pulse, antenna, mm-wave

□ Narrowband pulse measurements (Option H08)

This option extends the pulsed-RF measurement capability of the PNA-X to pulse widths below 250 ns, which is the limit for the standard wideband detection mode. The PNA-X is a complete pulsed-RF solution with built in pulse generators and modulators, so external test sets and pulse generators are not required. Option H08 provides software to set up and control narrowband pulsed-RF measurements with point-in-pulse and pulse-profile capability. The software sets the coefficient of the PNA-X's digital-IF filters to null out unwanted spectral components, enables the internal receiver IF gates on the rear panel, controls internal pulse generators (Option 025), internal pulse modulators (Option 021 and/or 022 or Option 036 and/or 037) or external pulse modulators, and performs optimization for measurement sensitivity. The measurement software can run on the PNA-X or an external computer. A ".dll" file containing the IF-filter algorithms is included for automated pulsed-RF testing. The N1966A pulse I/O adapter is recommended if using external pulse generators and/or external pulse modulators.

□ Add IF inputs for antenna and millimeter-wave (Option 020)

This option enables external IF inputs on the rear panel of the PNA-X for applications such as antenna and millimeter-wave test.

□ Add pulse modulator to internal first source (Option 021)

This option enables the internal pulse modulator on source 1. Control of the modulator can also be done via pin 8 of the Pulse I/O D-sub connector on the rear panel of the PNA-X using an external pulse generator, or by using one of the internal pulse generators (Option 025). The N1966A pulse I/O adapter is recommended if using an external pulse generator. (See diagram below for details of the D-sub connector.)

□ Add pulse modulator to internal second source (Option 022)

This option enables the internal pulse modulator on source 2. Control of the modulator can also be done via pin 8 of the Pulse I/O D-sub connector on the rear panel of the PNA-X using an external pulse generator, or by using one of the internal pulse generators (Option 025). The N1966A pulse I/O adapter is recommended if using an external pulse generator. Option 224 or 400 required. (See diagram for details of the D-sub connector.)

□ Add four internal pulse generators (Option 025)

This option enables four internal pulse generators. These pulse generators can be used to control the internal pulse modulators and internal receiver IF gates, and are also available on pins 10 through 13 of the Pulse I/O D-sub connector on the rear panel of the PNA-X to control external modulators and/or gates. The N1966A pulse I/O adapter is recommended if using external pulse modulators. (See diagram for details of the D-sub connector.)

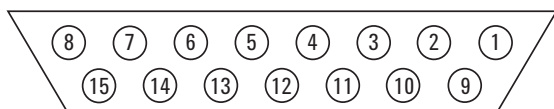

Pulse I/O D-sub connector (DB-15 female)

□ Add wide-pulse modulator to internal first source (Option 036)

This option enables the internal pulse modulator on source 1 with a restriction of minimum pulse width of 150 ns. Control of the modulator can be done by using one of the internal pulse generators (Option 025). External pulse inputs on the Pulse I/O D-sub connector on the rear panel are disabled.

□ Add wide-pulse modulator to internal second source (Option 037)

This option enables the internal pulse modulator on source 2 with a restriction of minimum pulse width of 150 ns. Control of the modulator can also be done by using one of the internal pulse generators (Option 025). External pulse inputs on the Pulse I/O D-sub connector on the rear panel are disabled. Option 224 or 400 required.

□ Fast CW Sweep (Option 118)

This option uses FIFO (first-in first-out) to allow external point-trigger acquisition of 400,000 data points per second on five measurement receivers. When enabled, there is no display update, no background computation, or other interference from the vector network analyzer application. All the data gathered is placed into a 500 million points FIFO buffer. While the data is going into FIFO it can be read from the FIFO buffer.

Accessories

□ Rack mount kit without handles (Option 1CM)

Adds a rack mount (5063-9217) and rail kit (E3663AC) for use without handles.

□ Pulse I/O adapter (N1966A)

An adapter for connecting between the Pulse I/O connector on the rear panel of the PNA-X and the coaxial inputs and outputs of external pulse generators and external pulse modulators. Coaxial connectors are SMB-male. The PULSE IN connectors are for controlling the PNA-X's internal IF gates, which are enabled with Option H08 and used with narrowband detection. The PULSE OUT connectors are from the PNA-X's four internal pulse generators, which are enabled with Option 025. The PULSE SYNC IN connector is used to synchronize the internal pulse generators with an external timing pulse. The RF PULSE MOD IN connector controls the internal pulse modulator(s) which are enabled with Options 021 and 022.



Pulse I/O adapter (N1966A) simplifies connections

PNA-X Series Network Analyzer

Upgrade kits

Upgrade kits are available to add options after initial purchase. To upgrade the PNA-X, order the corresponding item number. The model and serial numbers of the instrument to be retrofitted are required as part of the order.

	Description	Required option	For N5241A	For N5242A	For N5244A	For N5245A	User installable
Frequency upgrade							
N5242A	Extend analyzer's frequency range to 26.5 GHz	N5241A	N5241AU-960	n/a	n/a	n/a	no
N5245A	Extend analyzer's frequency range to 50 GHz	N5244A	n/a	n/a	N5244AU-990	n/a	no
Test set							
Option 224	2-ports, add internal 2nd source, combiner and mechanical switches	Options 200, 219	N5241AU-922	N5242AU-922	N5244AU-922	N5245AU-922	no
Option 423	4-ports, add internal combiner and mechanical switches	Options 400, 419	N5241AU-927	N5242AU-927	N5244AU-927	N5245AU-927	no
Power configuration							
Option 219	2-ports, extended power range and bias-tees	Option 200	N5241AU-921	N5242AU-921	N5244AU-921	N5245AU-921	no
Option 285	2-ports, extended power range, high-power configuration (no bias-tees)	Option 219 or 224	N5241AU-H85	N5242AU-H85	N5244AU-H85	N5245AU-H85	no
Option 419	4-ports, extended power range and bias-tees	Option 400	N5241AU-926	N5242AU-926	N5244AU-926	N5245AU-926	no
Option 485	4-ports, extended power range, high-power configuration (no bias-tees)	Option 419 or 423	N5241AU-H85	N5242AU-H85	N5244AU-H85	N5245AU-H85	no
Measurement applications							
Option 010	Time-domain measurements		N5241AU-010	N5242AU-010	N5244AU-010	N5245AU-010	yes
Option 029	Fully-corrected noise figure measurements for 2-port	Option 219, 224, or 285, and 080	N5241AU-924	N5242AU-924	n/a	n/a	no
Option 029	Fully-corrected noise figure measurements for 4-port	Option 419, 423, or 485, and 080	N5241AU-929	N5242AU-929	n/a	n/a	no
Option 080	Frequency offset		N5241AU-080	N5242AU-080	N5244AU-080	N5245AU-080	yes
Option 082	Scalar-calibrated converter measurements	Option 080	N5241AU-082	N5242AU-082	N5244AU-082	N5245AU-082	yes
Option 083	Vector- and scalar-calibrated converter measurements	Option 080	N5241AU-083	N5242AU-083	N5244AU-083	N5245AU-083	yes
Option 084	Embedded LO measurements	Option 029, 082, 083, or 087	N5241AU-084	N5242AU-084	N5244AU-084	N5245AU-084	yes
Option 086	Gain compression application		N5241AU-086	N5242AU-086	N5244AU-086	N5245AU-086	yes
Option 087	Intermodulation distortion application	Option 224 or 423	N5241AU-087	N5242AU-087	N5244AU-087	N5245AU-087	yes
Option 460	Integrated true-mode stimulus application	Option 400	N5241AU-460	N5242AU-460	N5244AU-460	N5245AU-460	yes
Option 551	N-port capabilities		N5241AU-551	N5242AU-551	N5244AU-551	N5245AU-551	yes
Nonlinear vector network analysis							
Option 510	Nonlinear component characterization	Options 419, 080	N5241AU-510	N5242AU-510	N5244AU-510	N5245AU-510	yes
Option 514	Nonlinear X-parameters	Options 423, 510	N5241AU-514	N5242AU-514	N5244AU-514	N5245AU-514	yes
Option 518	Nonlinear pulse envelope domain	Options 021 or 036, 025 and either one of 510 or 514	N5241AU-518	N5242AU-518	N5244AU-518	N5245AU-518	yes
Option 520	Arbitrary load-impedance X-parameters	Option 514	N5241AU-520	N5242AU-520	N5244AU-520	N5245AU-520	yes

PNA-X Series Network Analyzer

Upgrade kits continued

Upgrade kits are available to add options after initial purchase. To upgrade the PNA-X, order the corresponding item number. The model and serial numbers of the instrument to be retrofitted are required as part of the order.

Description	Required option	For N5241A	For N5242A	For N5244A	For N5245A	User installable	
Pulse, antenna, mm-wave							
Option H08	Pulse measurements	Option 025	N5241AU-H08	N5242AU-H08	N5244AU-H08	N5245AU-H08	yes
Option 020	Add IF inputs for antenna and mm-wave		N5241AU-020	N5242AU-020	N5244AU-020	N5245AU-020	yes
Option 021	Add pulse modulator to internal 1st source		N5241AU-021	N5242AU-021	N5244AU-021	N5245AU-021	yes
Option 022	Add pulse modulator to internal 2nd source	Option 224 or 400	N5241AU-022	N5242AU-022	N5244AU-022	N5245AU-022	yes
Option 025	Add four internal pulse generators		N5241AU-025	N5242AU-025	N5244AU-025	N5245AU-025	yes
Option 036	Add wide-pulse modulator to internal 1st source		n/a	n/a	N5244AU-036	N5245AU-036	yes
Option 037	Add wide-pulse modulator to internal 2nd source	Option 224 or 400	n/a	n/a	N5244AU-037	N5245AU-037	yes
Option 118	Fast CW sweep		N5241AU-118	N5242AU-118	N5244AU-118	N5245AU-118	yes
Calibration Software							
Option 897	Perpetual license for built-in performance test software for Agilent inclusive calibration		N5241AU-897	N5242AU-897	N5244AU-897	N5245AU-897	yes
Option 898	Perpetual license for built-in performance test software for standards compliant calibration		N5241AU-898	N5242AU-898	N5244AU-898	N5245AU-898	yes

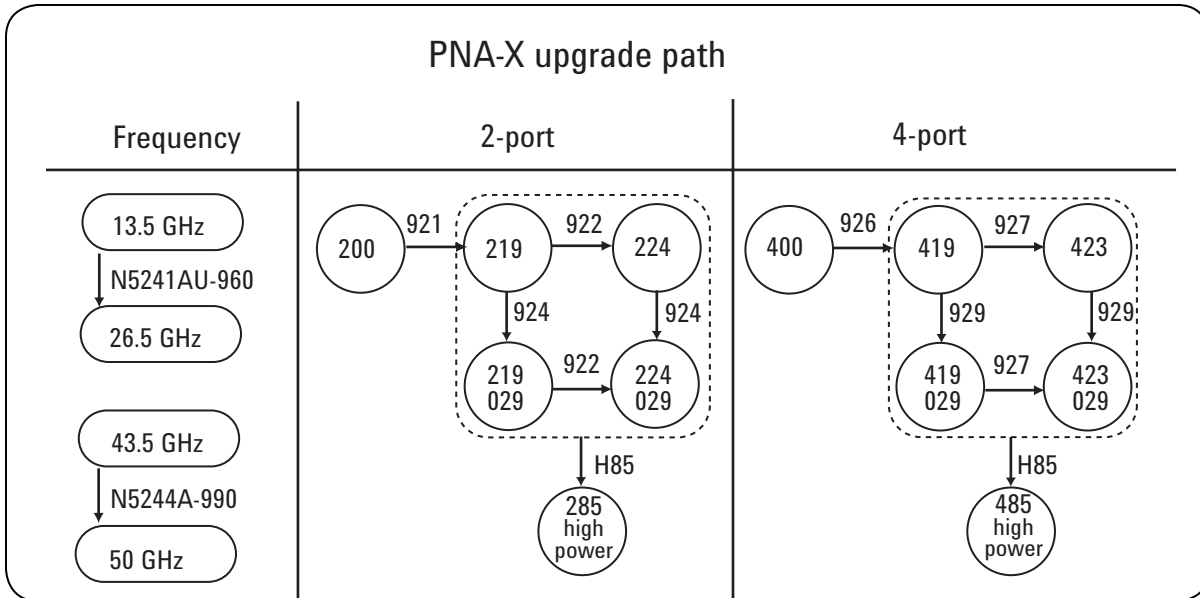

PNA Series Network Analyzer¹

E8362C	10 MHz to 20 GHz	E8361C	10 MHz to 67 GHz
E8363C	10 MHz to 40 GHz	N5250C ²	10 MHz to 110 GHz
E8364C	10 MHz to 50 GHz		

Option configurations

To add options to a product, order the corresponding item number.

	Description	For E8362C	For E8363C	For E8364C	For E8361C	For N5250C system ³	Additional information
Test set							
Option 014	• Configurable test set	E8362C-014	E8363C-014	E8364C-014	E8361C-014	Included	
Power configuration							
Option UNL	• Extended power range and bias-tees	E8362C-UNL	E8363C-UNL	E8364C-UNL	E8361C-UNL	Included	Only E8361C requires 014
Option 016	• Add receiver attenuators	E8362C-016	E8363C-016	E8364C-016	E8361C-016	E8361C-016	Requires UNL (only E8361C also requires 014)
Option H85 ⁷	• High-power configuration	E8362CH85	E8363CH85	E8364CH85	Contact Agilent	Contact Agilent	Includes 014, 016, UNL ^{*4} , 080, 081
Measurement applications							
Option 010	• Time-domain capability	E8362C-010	E8363C-010	E8364C-010	E8361C-010	E8361C-010	Requires 014 (E8361C only, 081 required if UNL is also purchased)
Option 080	• Frequency offset	E8362C-080	E8363C-080	E8364C-080	E8361C-080	Included	
Option 081	• Reference receiver switch	E8362C-081	E8363C-081	E8364C-081	E8361C-081	Included	Requires 014, 080 (only E8361C also requires UNL)
Option 082	• Scalar-calibrated converter measurements	E8362C-082	E8363C-082	E8364C-082	E8361C-082	E8361C-082 ⁵	Requires 014, 080
Option 083	• Vector- and scalar-calibrated converter measurements	E8362C-083	E8363C-083	E8364C-083	E8361C-083	E8361C-083 ⁵	Requires 014, 080, 081 (only E8361C also requires UNL)
Option 084 ⁶	• Embedded LO measurements	E8362C-084	E8363C-084	E8364C-084	E8361C-084	E8361C-084	Requires 082 or 083
Option 550 ⁹	• 4-port measurement application	E8362C-550	E8363C-550	E8364C-550	E8361C-550	n/a	Requires 014
Option 551 ⁹	• N-port capabilities	E8362C-551	E8363C-551	E8364C-551	E8361C-551	n/a	Requires 014
Pulse, antenna, mm-wave							
Option H08	• Pulsed-RF measurement capability	E8362C-H08	E8363C-H08	E8364C-H08	E8361C-H08	E8361C-H08 ⁵	Requires 014, 080
Option H11	• IF access (for antenna, pulsed-RF and mm-wave measurements)	E8362C-H11	E8363C-H11	E8364C-H11	E8361C-H11	Included	Requires 014, UNL, 080, and 081
Accessories							
Option 1CM	• Rack mount kit for use without handles	E8362C-1CM	E8363C-1CM	E8364C-1CM	E8361C-1CM	E8361C-1CM	
Option 1CP	• Rack mount kit for use with handles	E8362C-1CP	E8363C-1CP	E8364C-1CP	E8361C-1CP	E8361C-1CP	
N4688A	• USB CD R/W drive	N4688A	N4688A	N4688A	N4688A	N4688A	
N4689A	• USB Hub	N4689A	N4689A	N4689A	N4689A	N4689A	
Calibration documentation							
Option 1A7	• ISO 17025 compliant calibration	E8362C-1A7	E8363C-1A7	E8364C-1A7	E8361C-1A7	E8361C-1A7	
Option UK6	• Commercial calibration certificate with test data	E8362C-UK6	E8363C-UK6	E8364C-UK6	E8361C-UK6	E8361C-UK6	
Option A6J	• ANSI Z540 compliant calibration	E8362C-A6J	E8363C-A6J	E8364C-A6J	E8361C-A6J	E8361C-A6J	
Calibration software for self-maintainers							
Option 897 ⁸	• Perpetual license of built-in performance test software for Agilent exclusive calibration	E8362C-897	E8363C-897	E8364C-897	E8361C-897	E8361C-897	
Option 898 ⁸	• Perpetual license of built-in performance test software for standards compliant calibration	E8362C-898	E8363C-898	E8364C-898	E8361C-898	E8361C-898	

1. All models are not available in all countries.

2. For more detailed information regarding the 110 GHz network analyzer system, refer to the Agilent Web site: www.agilent.com/find/pna and download the N5250C Technical Overview, literature number 5989-7620EN.

3. The N5250C 110 GHz system also includes an N5260A millimeter-wave test set controller, 1.0 mm combiner assembly, interconnect cables, and installation and productivity assistance.

4. UNL* does not include bias-tees. Only includes source attenuators.

5. Up to 67 GHz.

6. Requires firmware A.07.05 and above, plus 1.1 GHz CPU board.

7. Option H85 is ordered as a separate model, as indicated.

8. Additional hardware required. Please refer to the analyzer's Service Guide for required service test equipment.

9. Option 550 is a subset of 551; therefore they cannot be ordered together.

PNA Series Network Analyzer

The microwave PNA Series instruments are integrated vector network analyzers equipped with a built-in S-parameter test set, synthesized source, a hard disk drive, USB interfaces, and an 8.4" LCD color touch screen display. The E8362C has 3.5 mm male 50-ohm test ports. The E8361C has 1.85 mm male 50-ohm test ports. Included with each instrument is a mouse, keyboard (U.S.) and a 1-year return-to-Agilent service warranty.

- E8362C network analyzer, 10 MHz to 20 GHz
- E8363C network analyzer, 10 MHz to 40 GHz
- E8364C network analyzer, 10 MHz to 50 GHz
- E8361C network analyzer, 10 MHz to 67 GHz¹
- N5250C network analyzer system, 10 MHz to 110 GHz

Test set and power configuration options

Configurable test set (Option 014)²

Provides six front panel access loops. Three access loops are for port one and three for port two. The loops provide access to the signal path between (a) the source output and the reference receiver, (b) the source output and directional coupler thru arm and (c) the coupled arm of the directional coupler and the port receiver. This option provides the capability to improve instrument sensitivity for measuring low-level signals, to reverse the directional coupler to achieve even more dynamic range or to add components and other peripheral instruments for a variety of measurement applications. (see *PNA Series Microwave Data Sheet* literature number 5989-7605EN for a basic block diagram)

Extended power range and bias-tees (Option UNL)²

Adds two 60 dB step attenuators and two bias-tees to the E8362/3/4C. Adds two 50 dB step attenuators and two bias-tees to the E8361C. A step attenuator and bias-tee set is inserted between the source and test port one and another set between the source and test port two. (see *PNA Series Microwave Data Sheet* literature number 5989-7605EN for a basic block diagram)

Add receiver attenuators (Option 016)

An attenuator is added between each test port and its corresponding receiver. Two 35 dB step attenuators are added to the E8362/3/4C. Two 50 dB step attenuators are added to the E8361C (see *PNA Series Microwave Data Sheet* literature number 5989-7605EN for a basic block diagram).

High-power test set (Model E836xCH85)

This configuration combines options that are often necessary for high power measurements (UNL³, 014, 016, 080, 081). The only difference between ordering Option H85 versus a combination of the options listed above is the source attenuator option UNL. Standard UNL includes two source attenuators and two bias-tees. Option H85 includes the two source attenuators, but not the bias-tees, as the bias-tees are the power-limiting factor in the network analyzer test set. The maximum power at the test port is +43 dBm (< 20 GHz), and +40 dBm (> 20 GHz).

Option 080, frequency-offset mode, is included in Option H85 because it manages the phase-locking internally (instead of depending on the R1 receiver). So if you need to use external components in the path of the R1 receiver, it makes the measurements simpler and more robust.

Measurement applications

Time-domain capability (Option 010)

For viewing reflection and transmission responses in time or distance domain.

Frequency offset (Option 080)²

This option enables the PNA Series microwave network analyzers to set the source frequency independently from where the receivers are tuned. This ability is important for two general classes of devices: mixers (and converters) and amplifiers. Option 080 provides a very basic user interface.

Reference receiver switch (Option 081)²

Option 081 adds a solid-state internal RF transfer switch in the R1 reference-receiver path (see *PNA Series Microwave Data Sheet* literature number 5989-7605EN for a block diagram). The switch allows the instrument to easily switch between standard S-parameter (non-frequency-offset) measurements and frequency offset measurements such as relative phase or absolute group delay that require an external reference mixer. The user can set the switch manually or remotely, but it is best used with the frequency-converter application (Option 083), where it is controlled automatically during the vector-mixer calibration procedure and subsequent measurements.

Scalar-calibrated converter measurements (Option 082)²

With a simple setup and calibration, this application provides the highest accuracy for conversion-loss (or gain) measurements by combining one-port and power-meter calibrations to remove mismatch errors. Option 080 required.

Vector- and scalar-calibrated converter measurements (Option 083)²

This converter measurement adds an intuitive and easy-to-use user interface, advanced calibration choices that provide exceptional amplitude and phase accuracy, and control of external signal sources for use as local oscillators. Mixer calibration techniques include scalar-mixer calibration and vector-mixer calibration (requires Option 081). Finally, the frequency-converter application supports all of Agilent's major signal source families.

Embedded LO Measurements (Option 084)

This option tunes the PNA receivers to the output frequency of the converter under test, without the need for access to internal LOs or a common reference signal. For converters with embedded LOs, this option enables measurements of match-corrected conversion loss/gain (requires Option 082 or 083), and absolute group delay (requires Option 083).

1. The E8361C can be extended to 110 GHz with IF access (Option H11).

2. Up to 67 GHz.

3. UNL* does not include bias-tees. Only includes source attenuators

PNA Series Network Analyzer

- 4-port measurement application (Option 550)¹**
Enables full 4-port error correction and differential measurements on a 2-port network analyzer with configurable test set. Option 014 required. External test set required.
- N-port capabilities (Option 551)¹**
Adds full N-port error correction and measurement capabilities to any PNA network analyzer with configurable test set. Option 014 required. External test set required.

Pulse, antenna, mm-wave

- Pulsed-RF measurement capability (Option H08)¹**
Provides software to set up and control pulsed-RF measurements with point-in-pulse capability. The software sets the coefficient of the PNA's digital-IF filter to null out unwanted spectral components, enables the IF gates provided with IF access (Option H11), and controls selected Agilent pulse generators. It can be run on the PNA or an external computer. A ".dll" file containing the IF-filter algorithms is included for automated pulsed-RF testing. The pulsed application is configured to work with the Agilent 81110A series pulse generator.

For more detailed information regarding pulsed measurement capabilities with the microwave PNA refer to the Agilent Web site www.agilent.com/find/pna and download the *PNA Series MW Network Analyzers Configuration Guide for Pulsed Measurements*, literature number 5989-7913EN.

- IF access (Option H11)**
Provides hardware to enable antenna, point-in pulse, and broadband millimeter-wave measurements to 110 GHz. For each of the MW PNA's measurement receivers, IF gates (enabled with pulsed measurement capability, Option H08) and external IF inputs are added. In addition, access to the PNA's internal RF and LO source is provided for remote mixing applications. For basic antenna measurements, only Option H11 is necessary. Pulsed antenna applications also require the pulsed measurement capability (Option H08). Broadband measurements to 110 GHz, also requires an N5260A millimeter-wave test set controller.

Note: Use external IF access for up to 20 dB more sensitivity when making antenna measurements with a remote mixing configuration. Add Option H08 (Pulsed-RF Measurement Capability) to enable advanced pulsed measurements. Or upgrade to a broadband (10 MHz to 110 GHz) VNA system simply by purchasing an N5260A controller test set with test heads (Option 110, 120, or 130).

Accessories

- Rack mount kit without handles (Option 1CM)**
Adds a rack mount (5063-9217) and rail kit (E3663AC) for use without handles.
- Rack mount kit with handles (Option 1CP)**
Adds a rack mount (5063-9237)² and rail kit (E3663AC) for use with standard supplied handles.

Configuration Details

Selecting the correct mixer-test configuration:

Most mixer or converter test applications require Options 014, 080, and 082 for conversion loss/gain, or Options 014, 080, 081 and 083 for conversion loss/gain and phase/delay measurements. If you want to create and automate your own custom frequency-offset measurements (for example, intermodulation distortion), you may only need Options 014 and 080. For converters that require input power below -27 dBm, or for devices that have a large amount of LO feedthrough (like an unfiltered mixer), Option UNL, which adds source attenuators, is highly recommended. Besides allowing lower input power levels, these attenuators improve the isolation between the PNA's internal source and LO leakage signals, helping to prevent source-unleveled errors. For devices that put out signals near or above the receiver's compression levels (which varies between -3 and +5 dBm, depending on the model and frequency), Option 016 is recommended, which adds receiver attenuators. Finally, Option 010, which adds time-domain analysis, is very useful for gating out unwanted, time-delayed responses which often occur when measuring mixers.

1. Up to 67 GHz.

2. The 5063-9237 kit assumes you have the standard handles shipped with the instrument. If you do not have handles, order a 5063-9224 kit.

PNA Series Network Analyzer

Simplified test set block diagrams

Standard power range

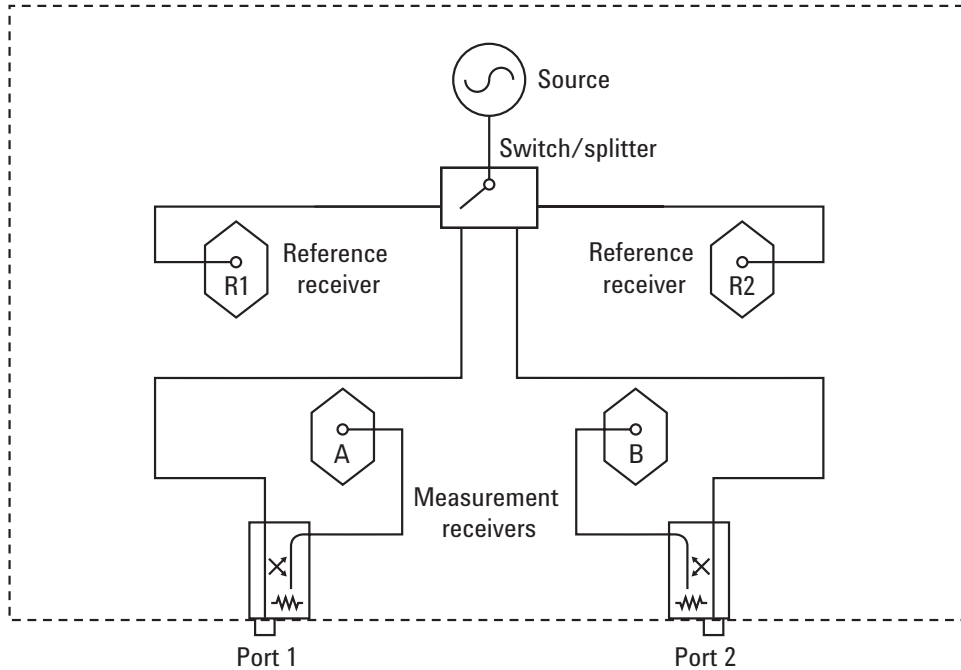

Extended power range and bias-tees (Option UNL)

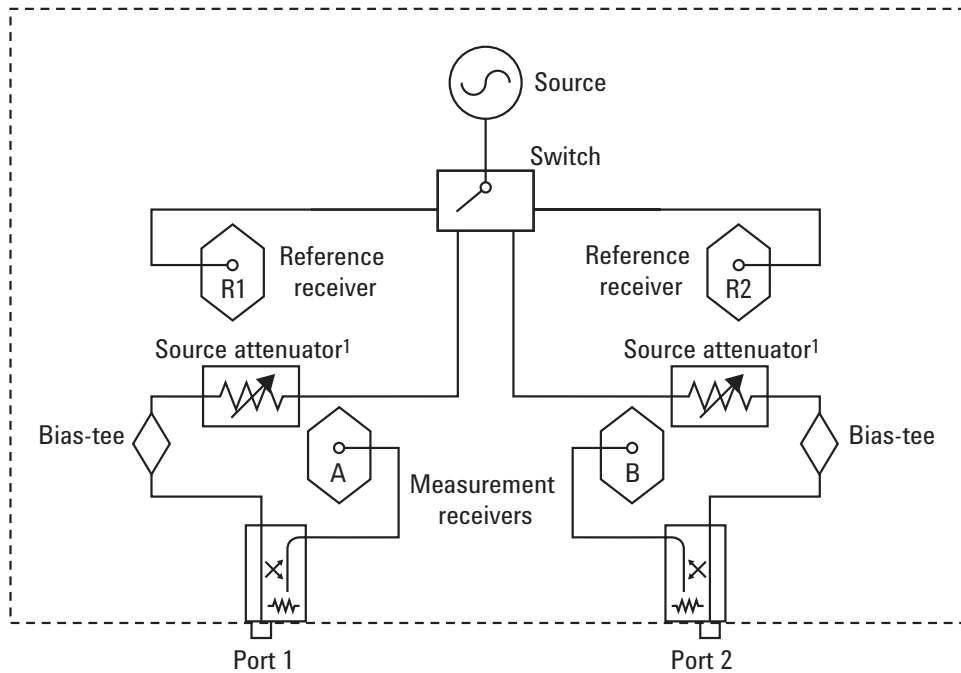

1. Source attenuator for E8362/3/4C is 60 dB in 10 dB steps.
Source attenuator for E8361C is 50 dB in 10 dB steps.

PNA Series Network Analyzer

Simplified test set block diagrams – continued

Configurable test set (Option 014)

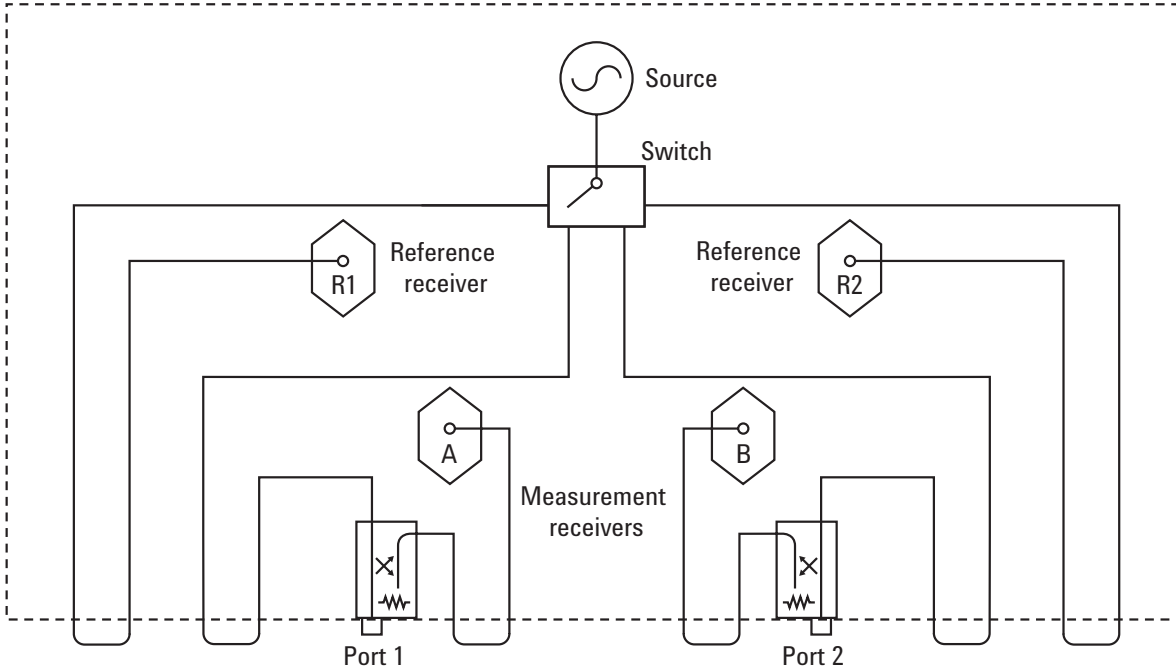

Configurable test set with extended power range and bias-tees (Option UNL and 014)

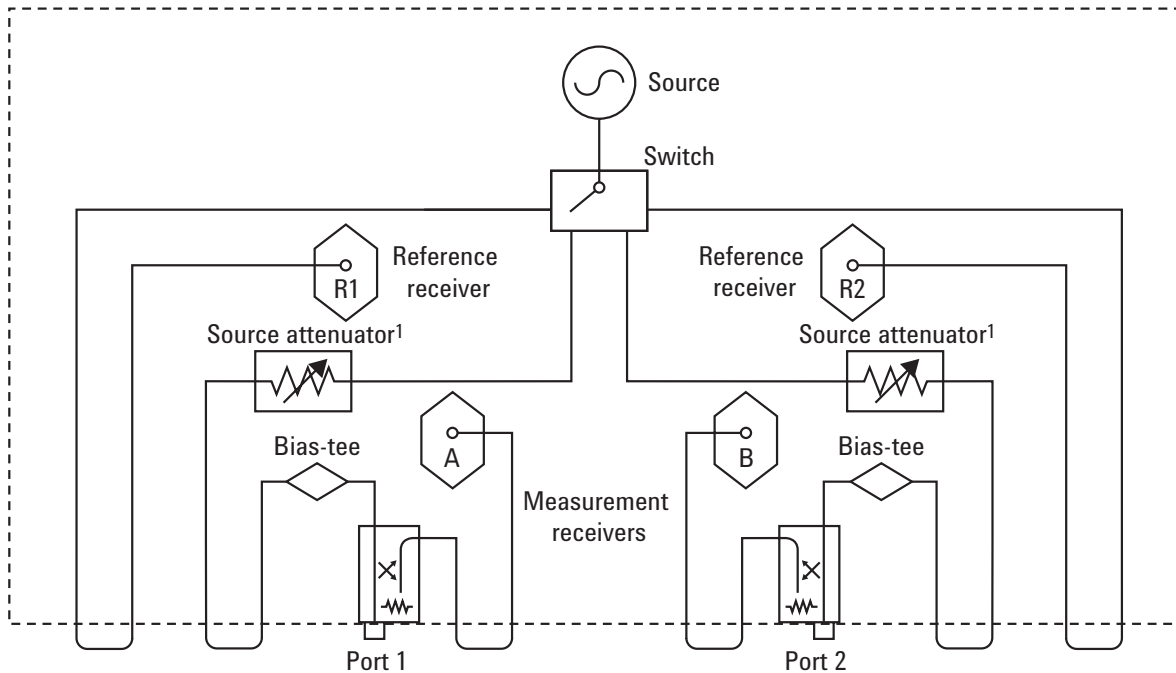

1. Source attenuator for E8362/3/4C is 60 dB in 10 dB steps.
Source attenuator for E8361C is 50 dB in 10 dB steps.

PNA Series Network Analyzer

Simplified test set block diagrams – continued

Fully optioned, active device or mixer/converter test configuration (Options 014, UNL, 016, 080, 081)

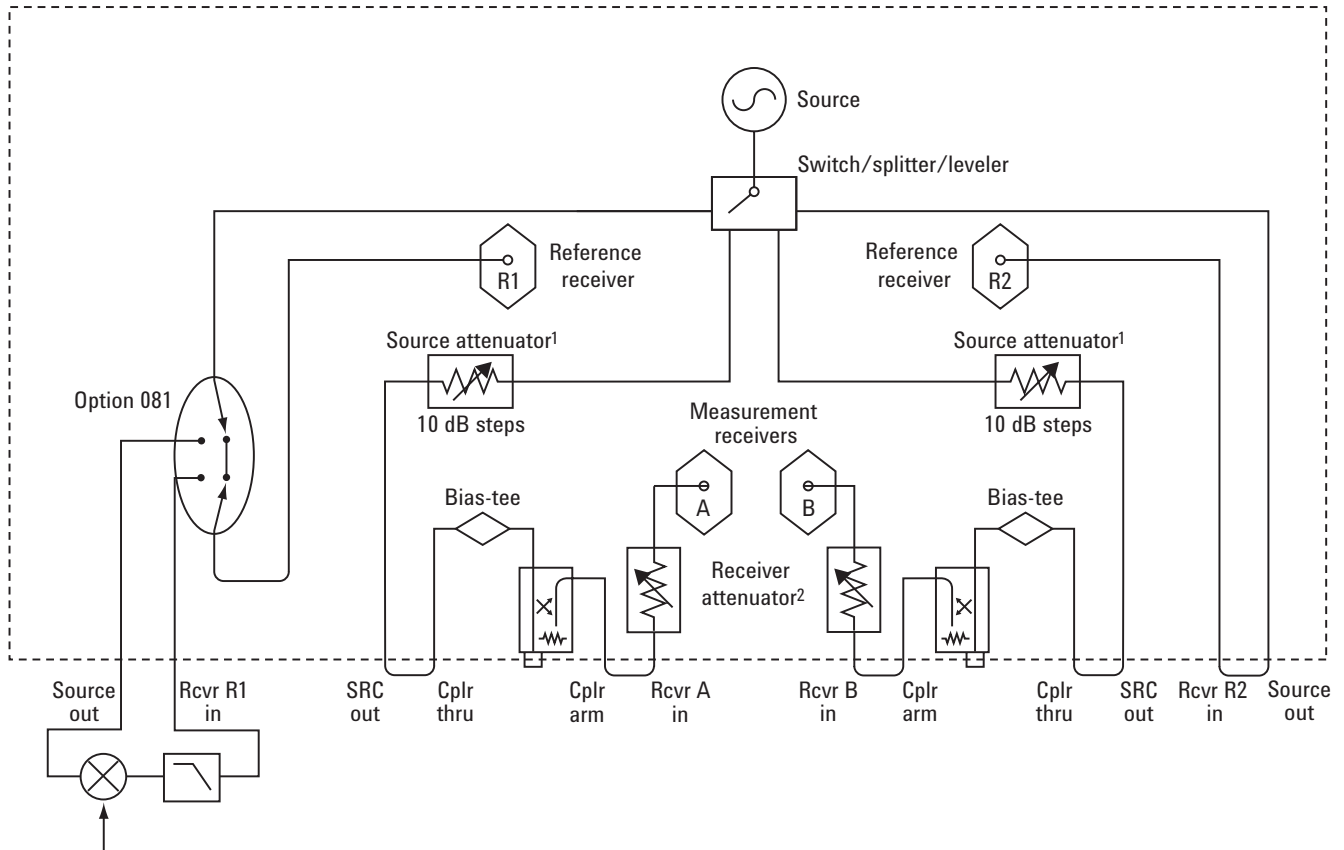

1. Source attenuator for E8362/3/4C is 60 dB in 10 dB steps. Source attenuator for E8361C is 50 dB in 10 dB steps.
2. Receiver attenuator for E8362/3/4C is 35 dB in 5 dB steps. Receiver attenuator for E8361C is 50 dB in 10 dB steps.

PNA Series Network Analyzer

Simplified test set block diagrams – continued

High-power configuration (Model E836xCH85)

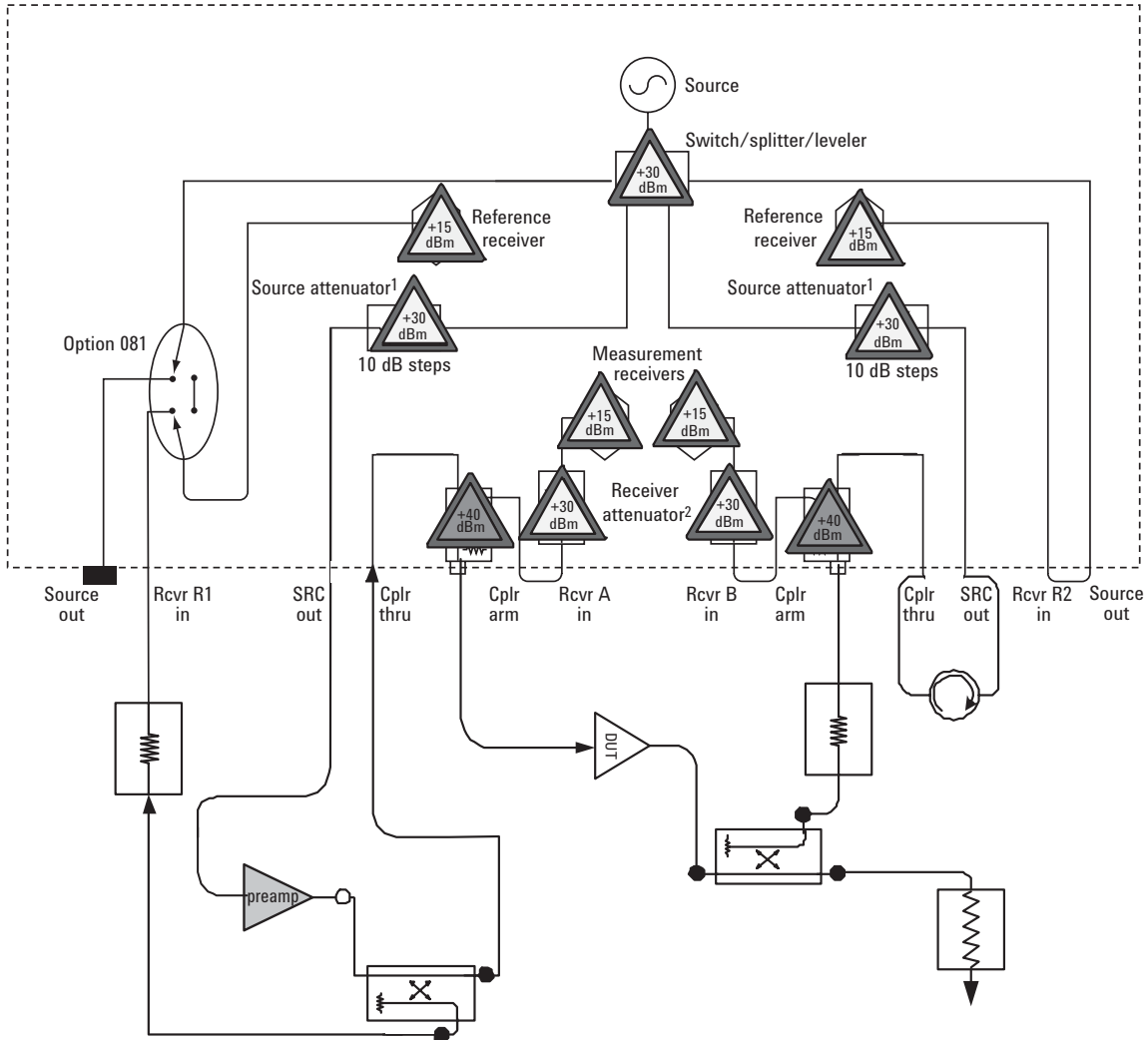

Power levels shown on the diagram are damage levels. At a minimum, keep power levels 6 dB below damage level. For optimal performance, keep the power level incident upon the receivers -20 dBm or less. This will keep the receivers out of compression.

1. Source attenuator for E8362/3/4C is 60 dB in 10 dB steps.
2. Receiver attenuator for E8362/3/4C is 35 dB in 5 dB steps.

PNA Series Network Analyzer

Simplified test set block diagrams – continued

Fully optioned, pulse-RF, antenna, or mm-wave configuration
(Options 014, UNL, 016, 080, 081, H11)

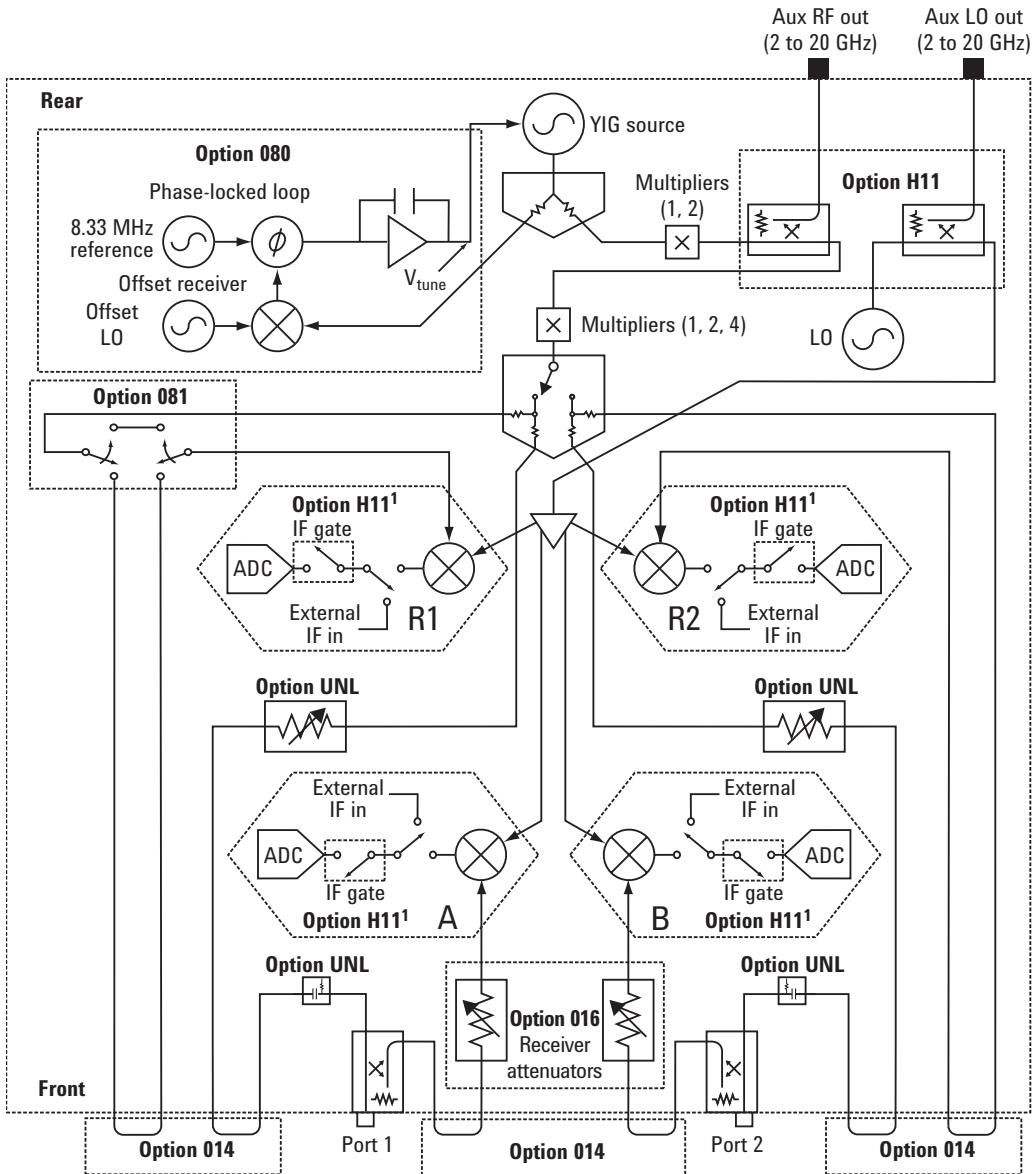

1. Option H11: IF-gate controls and external-IF inputs are accessed on rear panel. IF gates are enabled with Option H08. External-IF input frequency is 8.33 MHz.

PNA Series Network Analyzer

N5250C millimeter-wave system

□ N5250C MM PNA system¹, 10 MHz to 110 GHz, includes:

E8361C MW PNA with the following options:

- Configurable test set – Option 014
- Extended power range and bias-tees – Option UNL
- Frequency-offset mode – Option 080
- Reference channel switch – Option 081
- IF access – Option H11

N5260A millimeter-wave test set controller with test heads

- 67 to 110 GHz test heads
- 1.0 mm combiner assembly
- Interconnecting cables
- Installation and productivity assistance

Additional options available:

- Millimeter-wave modules with bias-tees - N5250C Option 017
- Millimeter-wave modules with bias-tees and port 2 attenuator - N5250C Option 018
- Receiver attenuator – Option 016
- Time-domain capability – Option 010
- Pulsed-RF measurement capability – Option H08²
- Scalar-calibrated converter measurements – Option 082²
- Frequency converter application – Option 083²

Factory integration of the N5250C system integrates the E8361C with Option H11 and the N5260A millimeter-wave controller with test heads. On-site installation is included, and the entire system carries a full one-year, on-site warranty (where available).

Option Descriptions

□ Millimeter-wave modules with bias-tees (N5250C Option 017)

Adds 67 GHz bias-tees to the combiner assembly between the input to the combiner and the 67 GHz coupler. The bias-tees have tri-axial connectors for force, sense, and ground. Positioning the bias-tees close to the DUT greatly improves stability for on-wafer and in-fixture devices. The bias-tees added for this option have a voltage rating of 40 volts and a maximum of 0.5 amps.

□ Millimeter-wave modules with bias-tees and port 2 attenuator (N5250C Option 018)

Adds 67 GHz bias-tees to the combiner assembly between the input to the combiner and the 67 GHz coupler. The bias-tees have tri-axial connectors for force, sense, and ground. Positioning the bias-tees close to the DUT greatly improves stability for on-wafer and in-fixture devices. The bias-tees added for this option have a voltage rating of 40 volts and a maximum of 0.5 amps. Additionally, Option 018 adds a 25 dB micrometer attenuator to the port 2 test head.

Banded waveguide solution

In order to assemble a banded waveguide solution, the following components are needed:

- Microwave PNA network analyzer (E8361C or E8362/3/4C) with the following options:
 - IF access - Option H11
 - Configurable test set - Option 014
 - Extended power range and bias-tees - Option UNL
 - Frequency-offset mode - Option 080
 - Reference channel switch - Option 081
- Millimeter-wave test set controller (N5260A) with no options
- A set of waveguide modules:
 - N5256AW15, 50 to 75 GHz
 - N5256AW12, 60 to 90 GHz
 - N5256AW10, 75 to 110 GHz
 - N5256AW08, 90 to 140 GHz
 - N5256AW06, 110 to 170 GHz
 - N5256AW05, 140 to 220 GHz
 - N5256AW03, 220 to 325 GHz

NOTE: To significantly improve system dynamic range above 220 GHz, Agilent strongly recommends adding two external synthesizers such as Agilent's PSG Series signal generators; one for the RF signal, and one for the LO signal.

For more detailed information, see *PNA Millimeter-wave Technical Overview*, literature number 5989-7620EN.

On-wafer applications

For on-wafer applications, Cascade Microtech³ provides complete probing systems using the N5250C. These include both new probing systems and upgrades to existing Cascade Microtech products. Cascade can also provide on-wafer verification and probing system training. Once the N5250C system is verified in coax, Cascade Microtech will verify the system through its wafer probes.

PNA Series Network Analyzer

N5250C millimeter-wave system – continued

With Option 017, the signal is routed out of the PNA from the front panel jumpers rather than the ports. Without Option 017, the signal is routed from the front panel ports to the combiner assembly, allowing access to the PNA's internal bias-tees.

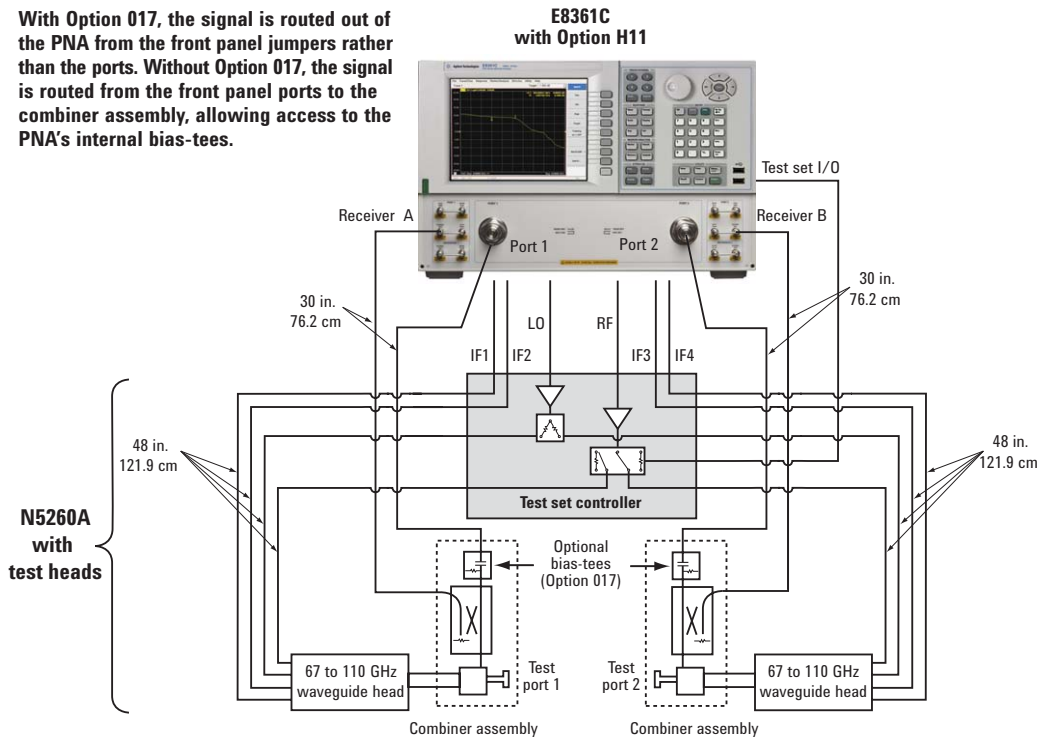

PNA test set block diagram

Simplified receiver block diagram

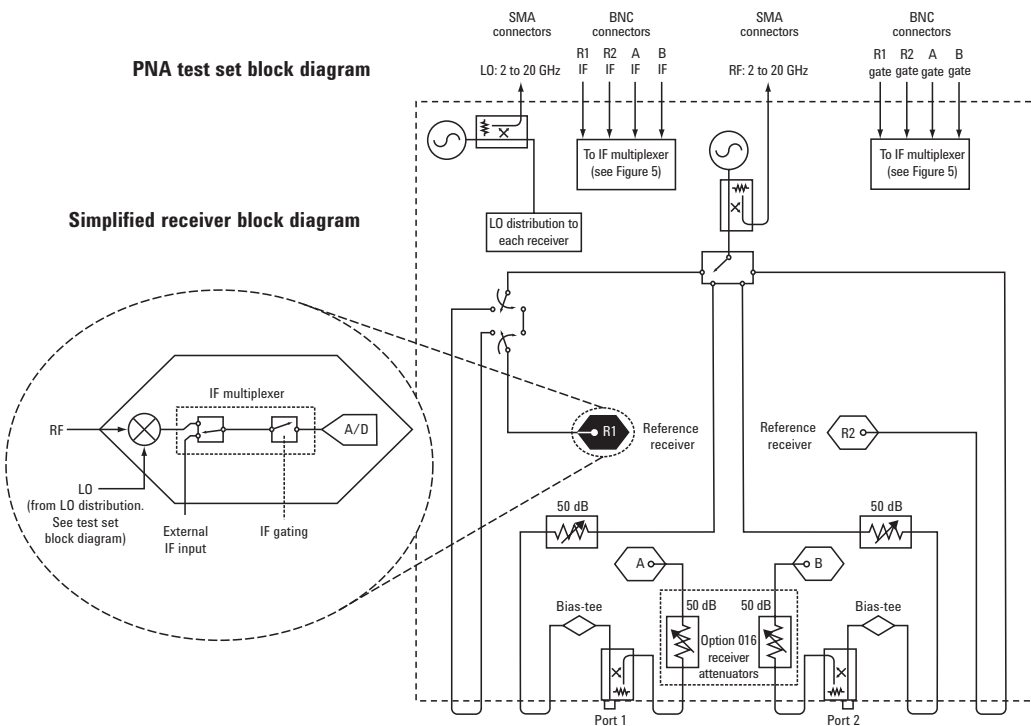

PNA Series Network Analyzer

Upgrade kits

Upgrade kits for the PNA Series E8361C, E8362C, E8363C, E8364C, N5250C¹

Upgrade kits are available to add options after initial purchase. To order an upgrade kit for the PNA series, order the analyzer's model number followed by a "U", then indicate the option to be added (for example, E8362CU-010). The current configuration and serial number of the instrument to be retrofitted are required as part of the order.

- Time-domain** (Option 010)
User installable.
- Configurable test set** (Option 014)
Provides six front-panel RF access loops.
Includes installation at an Agilent service center.
- Receiver attenuators** (Option 016)
Includes installation at an Agilent service center.
- Frequency range upgrade to an E8363C (40 GHz) PNA** (Option 040/041)
Available only for the E8362C. Includes installation at an Agilent service center.
- Frequency range upgrade to an E8364C (50 GHz) PNA** (Option 050/051)
Available only for the E8362C and E8363C.
Includes installation at an Agilent service center.
- Frequency range upgrade to an E8361C (67 GHz) PNA** (Option 067/068)
Available only for the E8363C and E8364C.
Includes installation at an Agilent service center.
- Frequency-offset** (Option 080)
Includes installation at an Agilent service center.
- External reference switch** (Option 081)
Includes installation at an Agilent service center.
- Scalar-calibrated converter measurements** (Option 082)
User installable. Option 080 required.
- Frequency converter measurement application** (Option 083)
User installable. Option 080 and 081 required.
- Embedded LO Measurements** (Option 084)
Advanced software tuning that provides absolute group delay of converters with embedded LOs without the need for access to a common reference signal. The measurement result is the same as locking the DUT LO to the reference mixer LO. (Options 080 and 083 required) Requires firmware A.07.05 and above plus 1.1 GHz CPU board.
- A/B to C model upgrades**
Order E8361AU-221, E8362BU-221, E8363BU-221, or E8364BU-221
- 4-Port measurement application** (Option 550)
(Available for E8361C, E8362C/3C/4C)
Enables full 4-port error correction and differential measurements. Option 014 and external test set required.
User installable.

- N-port capabilities** (Option 551)
(Available for E8361C, E8362C/3C/4C)
Adds full N-port error correction and measurement capabilities. Option 014 and external test set required.
User installable.
- Extended power range** (Option UNL)
Adds a step attenuator and a bias-tee between source and each test port. Includes installation at an Agilent service center.
- Pulsed-RF measurement capability** (Option H08)
Provides software to set up and control pulsed-RF measurements using narrowband detection, with point-in-pulse and pulse-profile capability. User installable.
- IF access** (Option H11)
Provides hardware for antenna, point-in-pulse, and millimeter-wave measurements. Adds rear-panel RF and LO outputs, external IF inputs, and IF gates (gates enabled with Option H08). Includes installation at an Agilent service center.
- High-power test set** (Option H85)²
Removes bias tees for higher test port power-handling capability. Options UNL, 014, 016, 080, and 081 are required. Includes installation at an Agilent Service Center.

Calibration Software Licenses

- Perpetual license for built-in performance test software for Agilent inclusive cal (Option 897)**
Adds built-in performance testing and calibration software for self-maintainers. Requires additional equipment. See the analyzer's Service Guide for more information on equipment required.
- Perpetual license for built-in performance test software for standards compliant cal (Option 898)**
Adds built-in performance testing and calibration software for self-maintainers. Requires additional equipment. See the analyzer's Service Guide for more information on equipment required.

1. For N5250C upgrades, order upgrade options for E8361CU.

2. Please contact Agilent to order this upgrade.

PNA-L Series Network Analyzer

Option configurations

To add options to a product, order the corresponding item number.

	Description	For N5230C	Additional information
Frequency range and test set (Mandatory, choose only one)			
Option 020	300 kHz–6 GHz 2-port standard test set	N5230C-020	
Option 025	300 kHz–6 GHz 2-port configurable test set and extended power range	N5230C-025	
Option 120	300 kHz–13.5 GHz 2-port standard test set	N5230C-120	
Option 125	300 kHz–13.5 GHz 2-port configurable test set and extended power range	N5230C-125	
Option 140	300 kHz–13.5 GHz 4-port standard test set	N5230C-140	
Option 145	300 kHz–13.5 GHz 4-port configurable test set and extended power range	N5230C-145	
Option 146	300 kHz–13.5 GHz 4-port configurable test set, extended power range and internal second source	N5230C-146	Option 080 recommended
Option 220	10 MHz–20 GHz 2-port standard test set	N5230C-220	
Option 225	10 MHz–20 GHz 2-port configurable test set and extended power range	N5230C-225	
Option 240	300 kHz–20 GHz 4-port standard test set	N5230C-240	
Option 245	300 kHz–20 GHz 4-port configurable test set and extended power range	N5230C-245	
Option 246	300 kHz–20 GHz 4-port configurable test set, extended power range and internal second source	N5230C-246	Option 080 recommended
Option 420	10 MHz–40 GHz 2-port standard test set	N5230C-420	
Option 425	10 MHz–40 GHz 2-port configurable test set and extended power range	N5230C-425	
Option 520 ¹	10 MHz–50 GHz 2-port standard test set	N5230C-520	
Option 525 ¹	10 MHz–50 GHz 2-port configurable test set and extended power range	N5230C-525	
Measurement applications			
Option 010	Time domain for 6 GHz model	N5231C-010	
Option 010	Time domain for 13.5, 20, 40 or 50 GHz model	N5230C-010	
Option 080	Frequency offset measurements	N5230C-080	
Option 082	Scalar-calibrated converter measurements	N5230C-082	Option 080 required
Option 550 ²	4-port measurement application	N5230C-550	Not available on 4-port models.
Option 551 ²	N-port capabilities for 6, 13.5 or 20 GHz model	N5231C-551	Requires test set Option xx5 or xx6
Option 551 ²	N-port capabilities for 40 or 50 GHz model	N5230C-551	Requires test set Option xx5 or xx6
Accessories			
Option 1CM	Rack mount kit without handles	N5230C-1CM	
Option 1CP	Rack mount kit with handles	N5230C-1CP	
N4688A	USB CD R/W drive	N4688A	
N4689A	USB hub	N4689A	
Calibration documentation			
Option 1A7	ISO 17025 compliant calibration	N5230C-1A7	
Option A6J	ANSI Z540 compliant calibration	N5230C-A6J	
Option UK6	Commercial calibration certificate with test data	N5230C-UK6	
Calibration software for self-maintainers			
Option 897 ³	Perpetual license for built-in performance test software for Agilent inclusive calibration	N5230C-897	
Option 898 ³	Perpetual license for built-in performance test software for standards compliant calibration	N5230C-898	

1. Not available in all countries

2. Option 550 is a subset of 551; therefore they cannot be ordered together.

3. Additional hardware required. Please refer to the analyzer's Service Guide for required service test equipment.

PNA-L Series Network Analyzer

The PNA-L is an integrated vector network analyzer equipped with a built-in S-parameter test set, one or two synthesized sources used for device stimulus, a hard disk drive, USB interfaces, and an 8.4" LCD color touch screen display. 40 and 50 GHz models have 2.4 mm ruggedized male 50-ohm connectors, while all other models have 3.5 mm ruggedized male 50-ohm connectors. Included with each instrument is a mouse, keyboard (U.S.) and a 1-year return-to-Agilent service warranty.

Test set and power configuration options

- Standard test set and power range (Option xx0)**
 The 13.5 and 20 GHz versions are available in 2- or 4-ports.
- Configurable test set and extended power range (Option xx5)**
 Adds front panel access loops and one or two 60 dB step attenuators as shown in the figures below. This provides the capability to improve instrument sensitivity for measuring low-level signals, to reverse the directional couplers to achieve even more dynamic range or to add components and other peripheral instruments for a variety of measurement applications. The 13.5 and 20 GHz versions are available in 2- or 4-ports.
- Configurable test set, extended power range and internal second source (Option x46)**
 Available with 4-port models only, this option adds an internal second source, nine front panel access loops and two 60 dB step attenuators as shown in the figure below. This provides an additional signal (fixed or swept) for two-tone third-order-intercept (TOI) and intermodulation testing of amplifiers; or it can be used as a fast swept-LO signal for fixed-IF testing of mixers and converters. In either case, sweep speed is more than twenty times faster than using an external source (Option 080 recommended. *Please note*, Option 080 is needed in order to have independent control of the two internal sources.).

2-port standard test set

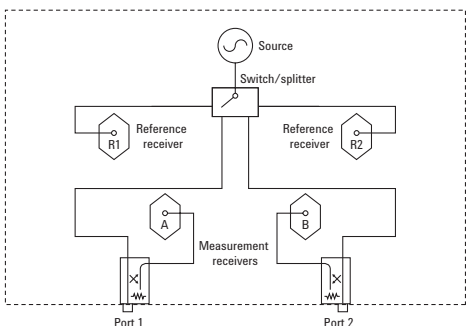

2-port configurable test set and extended power range

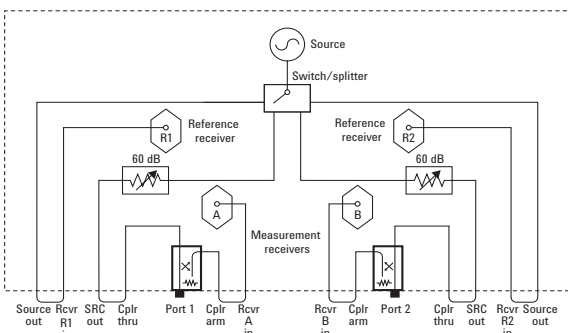

4-port standard test set

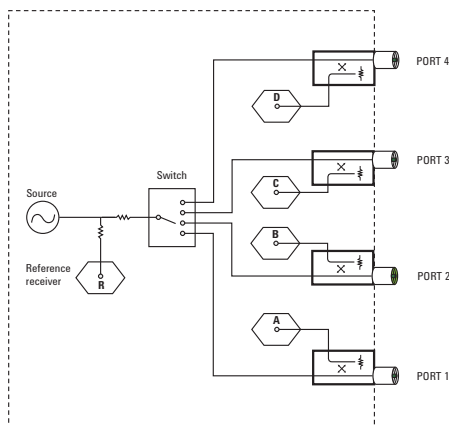

4-port configurable test set and extended power range

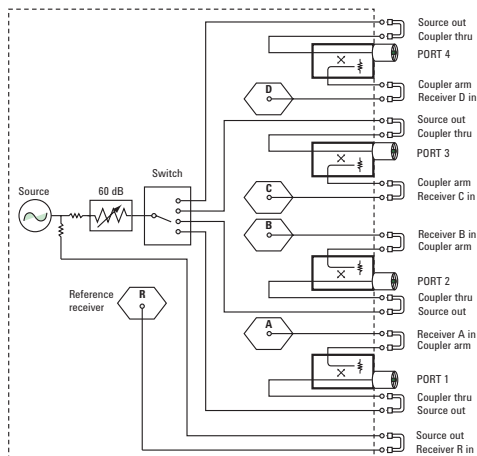

4-port configurable test set, extended power range and internal second source

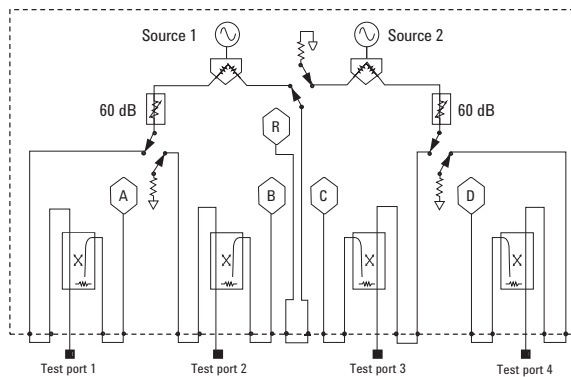

PNA-L Series Network Analyzer

Measurement applications

Time domain (Option 010)

This option enables the PNA Series to view reflection and transmission responses in both time or distance domain. Use time domain to tune filters, gate out the response of fixtures and cables, characterize the impedance of transmission line, and more.

Frequency offset (Option 080)

This option enables the PNA Series to set the source frequency independently from where the receivers are tuned. This ability is important for two general classes of devices: mixers (and converters) and amplifiers.

Scalar-calibrated converter measurements (Option 082)

With a simple setup and calibration, this application provides the highest accuracy for conversion-loss (or gain) measurements by combining one-port and power-meter calibrations to remove mismatch errors. Option 080 required.

4-port measurement application (Option 550)

Enables full 4-port error correction and differential measurements on a 2-port network analyzer with configurable test set (Option x25). External test set required. User installable.

N-port capabilities (Option 551)

Adds full N-port error correction and measurement capabilities to any PNA-L network analyzer with configurable test set (Option xx5 or x46). External test set required. User installable.

PNA-L Series Network Analyzer

Upgrade kits

Upgrade kits are available to add options after initial purchase. To order an upgrade kit for the PNA-L series, order the analyzer's model number followed by a "U", then indicate the option to be added (example: N5230CU-010). The serial number of the instrument to be retrofitted is required as part of the order.

- Time-domain upgrade kit (Option 010)**
The serial number of the instrument to be retrofitted must be specified when ordering this kit. User installable.
- Frequency-offset upgrade kit (Option 080)**
The serial number of the instrument to be retrofitted must be specified when ordering this kit. User installable.
- Scalar-calibrated converter measurements (Option 082)**
User installable. Option 080 required.
- 4-port measurement application (Option 550)**
Enables full 4-port error correction and differential measurements on a 2-port network analyzer with configurable test set (Option x25). External test set required. User installable.
- N-port capabilities (Option 551)**
Adds full N-port error correction and measurement capabilities to PNA-L with configurable test set (Option xx5 or x46). External test set required. User installable.
- 6 or 13.5 GHz configurable test set & extended power range upgrade kit (Option 901)**
Applicable to 6 or 13.5 GHz PNA-L (N5230C-020, N5230C-120). Upgrade to configurable test set and extended power range. Includes installation at an Agilent service center.
- 20 GHz 2-port configurable test set & extended power range upgrade kit (Option 922)**
Applicable to 20 GHz PNA-L (N5230C-220) Upgrade to configurable test set and extended power range. Includes installation at an Agilent service center.
- 13.5 or 20 GHz 4-port configurable test set & extended power range upgrade kit (Option 926)**
Applicable to 20 GHz 4-port PNA-L (N5230C-140, N5230C-240). Upgrade to configurable test set and extended power range. Includes installation at an Agilent service center.
- 13.5 GHz 4-port configurable test set, extended power range & internal second source upgrade kit (Option 928)**
Applicable to 13.5 GHz 4-port PNA-L (N5230C-145). Upgrade to configurable test set, extended power range and internal second source. Includes installation at an Agilent service center. (Option 080 recommended. Please note, Option 080 is needed in order to have independent control of the two internal sources.)

Calibration Software Licenses

- Perpetual license for built-in performance test software for Agilent inclusive cal (Option 897)**
Adds built-in performance testing and calibration software for self-maintainers. Requires additional equipment. See the analyzer's Service Guide for more information on equipment required.

- Perpetual license for built-in performance test software for standards compliant cal (Option 898)**
Adds built-in performance testing and calibration software for self-maintainers. Requires additional equipment. See the analyzer's Service Guide for more information on equipment required.
- A to C model upgrade**
Order N5230AU-221 for 2-port PNA-L, or N5230AU-241 for 4-port PNA-L.
- 20 GHz 4-port configurable test set, extended power range & internal second source upgrade kit (Option 927)**
Applicable to 20 GHz 4-port PNA-L (N5230C-245). Upgrade to configurable test set, extended power range and internal second source. Includes installation at an Agilent service center. Option 080 recommended.
- 40 or 50 GHz configurable test set & extended power range upgrade kit (Option 941)**
Applicable to 40 or 50 GHz PNA-L (N5230C-420, N5230C-520). Upgrade to configurable test set and extended power range. Includes installation at an Agilent service center.
- Frequency range upgrade from 6 to 13.5 GHz (Option 960)**
Applicable to the 6 GHz PNA-L (N5230C-020, N5230C-025). Includes installation at an Agilent service center.
- Frequency range upgrade from 13.5 to 20 GHz (Option 966)**
Applicable to the 13.5 GHz 4-port PNA-L (N5230C-140, N5230C-145, N5230C-146). Includes installation at an Agilent service center.
- Frequency range upgrade from 20 to 40 GHz (Option 971)**
Applicable to the 20 GHz PNA-L (N5230C-220). Includes installation at an Agilent service center.
- Frequency range upgrade from 20 to 40 GHz (Option 973)**
Applicable to the 20 GHz PNA-L (N5230C-225). Includes installation at an Agilent service center.
- Frequency range upgrade from 40 to 50 GHz (Option 990)**
Applicable to the 40 GHz PNA-L (N5230C-420, N5230C-425). Includes installation at an Agilent service center.

For additional upgrade paths, contact your Agilent field office.

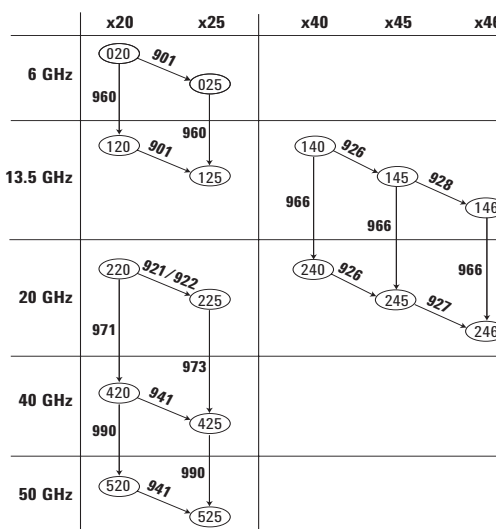

PNA-L upgrade path examples.

Measurement Accessories

A complete list of RF and microwave test accessories is available on our Web site:

www.agilent.com/find/accessories

Accessories are available in these connector types: 50 ohm Type-N, 3.5 mm, 7 mm, 2.4 mm, 2.92 mm, 1.85 mm, 1.0 mm, and waveguide. Test port cables and a calibration kit should be added for a complete measurement system. A verification kit is used to verify corrected system performance.

Cables and adapter sets

Agilent offers cables in the following types:

- single cables in semi-rigid and flexible
- cable sets in semi-rigid and flexible

There are also adapter sets available that protect the test port and convert the port to the desired connector interface. These kits contain:

- one male adapter
- one female adapter

To attain the best mechanical rigidity for device connection, use a single cable and the appropriate special adapter set. To attain the greatest flexibility for device connection, use a cable set.

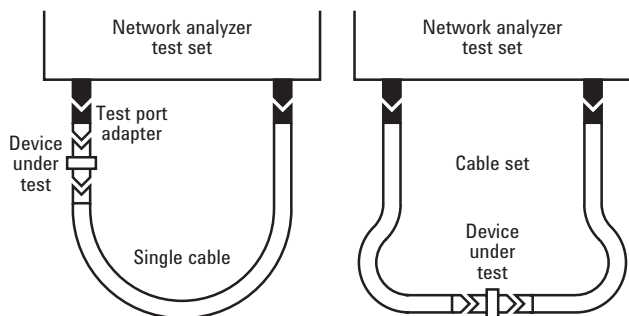

Calibration kits

Coaxial measurements

Mechanical calibration kits include standards, such as opens, shorts and loads, which are measured by the network analyzer for increased measurement accuracy.

Electronic calibration (ECal) kits replace mechanical calibration standards with one solid-state calibration module that is controlled by the network analyzer via USB, to present many different impedances to the test ports. A full two-port calibration can be performed quickly with a single connection. This technique reduces operator errors and connector wear and abrasion.

Choose a calibration kit for each connector type to be used.

Economy, includes:

- open standards (male and female)
- short standards (male and female)
- fixed-termination standards (male and female)

Standard, includes the devices in the economy kit and adds:

- sliding load standards (male and female) or a series of offset shorts

Precision, includes the devices in the economy kit and adds:

- 50 ohm airline(s) for TRL calibration
- TRL adapters

Waveguide measurements

For waveguide measurements, Agilent offers mechanical calibration kits that include:

- waveguide-to-coax adapters (X, P, K, R, Q, U, V)
- precision waveguide section
- flush short circuit
- fixed terminations
- straight section

For devices with 1.0 mm connectors

Mechanical calibration/verification kit

□ **85059A** DC to 110 GHz precision calibration/verification kit.

Includes:

85059-60003	1.00 mm (m) short 2.450 mm
85059-60007	1.00 mm (f) short 2.450 mm
85059-60004	1.00 mm (m) short 3.000 mm
85059-60008	1.00 mm (f) short 3.000 mm
85059-60002	1.00 mm (m) short 1.825 mm
85059-60006	1.00 mm (f) short 1.825 mm
85059-60001	1.00 mm (m) short 1.300 mm
85059-60005	1.00 mm (f) short 1.300 mm
85059-60009	1.00 mm male open
85059-60010	1.00 mm female open
85059-60019	1.00 mm male load
85059-60020	1.00 mm female load
85059-60021	1.00 mm lossy delay line
11920-60001	1.00 mm (m) to 1.00 mm (m) adapter
11920-60002	1.00 mm (f) to 1.00 mm (f) adapter
11920-60003	1.00 mm (m) to 1.00 mm (f) adapter
11500-60001	1.00 mm (f) to 1.00 mm (f) 8.8 cm cable
85059-60016	1.00 mm mismatch thru adapter for verification
85059-60017	1.00 mm matched thru adapter for verification
8710-2079	6 mm, 4 in-lb torque wrench
8710-2156	6 mm open end wrench

Cables

- **11500I** 1.0 mm (f-f) test port cable (8.8 cm)
- **11500J** 1.0 mm (m-f) test port cable (16.0 cm)¹
- **11500K** 1.0 mm (m-f) test port cable (20.0 cm)¹
- **11500L** 1.0 mm (m-f) test port cable (24.0 cm)¹

Adapter set

- **V281C** 1.0 mm(f) to V-band waveguide adapter
- **V281D** 1.0 mm (m) to V-band waveguide adapter
- **W281C** 1.0 mm (f) to W-band waveguide adapter
- **W281D** 1.0 mm (m) to W-band waveguide adapter
- **11920A** 1.0 mm (m) to 1.0 mm (m) adapter
- **11920B** 1.0 mm (f) to 1.0 mm (f) adapter
- **11920C** 1.0 mm (m) to 1.0 mm (f) adapter
- **11921A** 1.0 mm (m) to 1.85 mm (m) adapter
- **11921B** 1.0 mm (f) to 1.85 mm (f) adapter
- **11921C** 1.0 mm (m) to 1.85 mm (f) adapter
- **11921D** 1.0 mm (f) to 1.85 mm (m) adapter
- **11922A** 1.0 mm (m) to 2.4 mm (m) adapter
- **11922B** 1.0 mm (f) to 2.4 mm (f) adapter
- **11922C** 1.0 mm (m) to 2.4 mm (f) adapter
- **11922D** 1.0 mm (f) to 2.4 mm (m) adapter
- **11923A** 1.0 mm (f) connector launch assembly

1. For on-wafer applications, two 11500J/K/L cables are required; one cable for each test port.

2. Special rugged female connector specifically for connecting to the network analyzer test port, but does not mate with a standard male connector.

For devices with 1.85 mm connectors

Mechanical calibration kits

□ **85058B** standard: DC to 67 GHz.

Includes:

85058-60101	1.85 mm (m) short 5.4 mm
85058-60102	1.85 mm (m) short 6.3 mm
85058-60103	1.85 mm (m) short 7.12 mm
85058-60104	1.85 mm (m) short 7.6 mm
85058-60105	1.85 mm (f) short 5.4 mm
85058-60106	1.85 mm (f) short 6.3 mm
85058-60107	1.85 mm (f) short 7.12 mm
85058-60108	1.85 mm (f) short 7.6 mm
85058-60109	1.85 mm male open
85058-60110	1.85 mm female open
85058-60111	1.85 mm male load
85058-60112	1.85 mm female load
85058-60113	1.85 mm (m) to 1.85 mm (m) adapter
85058-60114	1.85 mm (f) to 1.85 mm (f) adapter
85058-60115	1.85 mm (m) to 1.85 mm (f) adapter

□ **85058E** economy: DC to 67 GHz.

Includes:

85058-60101	1.85 mm (m) short 5.4 mm
85058-60105	1.85 mm (f) short 5.4 mm
85058-60109	1.85 mm male open
85058-60110	1.85 mm female open
85058-60123	1.85 mm male load
85058-60124	1.85 mm female load
85058-60113	1.85 mm (m) to 1.85 mm (m) adapter
85058-60114	1.85 mm (f) to 1.85 mm (f) adapter
85058-60115	1.85 mm (m) to 1.85 mm (f) adapter

Electronic calibration kits

□ **N4694A** Microwave ECal: 10 MHz to 67 GHz, 2-ports.

Includes:

Option M0F module with:

N4694-60001 1.85 mm (f) to 1.85 mm (m) ECal module

Option 00M module with:

N4694-60002 1.85 mm (m) to 1.85 mm (m) ECal module

Option 00F module with:

N4694-60003 1.85 mm (f) to 1.85 mm (f) ECal module

Option 00A adds:

85058-60113 1.85 mm (m) to 1.85 mm (m) adapter

85058-60114 1.85 mm (f) to 1.85 mm (f) adapter

Cables

- **N4697E²** Single, flexible: 1.85 mm (f) to 1.85 mm (f), 96.5 cm, 38 inches
- **N4697F²** Set, flexible:
 - One 1.85 mm (f) to 1.85 mm (f) cable, 62.2 cm, 24.5 inches, p/n N4697-60100
 - One 1.85 mm (f) to 1.85 mm (m) cable, 62.2 cm, 24.5 inches, p/n N4697-60200
- **N4697H²** Single, flexible: 1.85 mm (f) to 1.85 mm (m), 62.2 cm, 24.5 inches
- **N4421B-B67** Set of 4, flexible: 1.85 mm (f) to 1.85 mm (m), 91.4 cm, 36 inches

Adapter set

- **85130H** 1.85 mm² to 1.85 mm

For devices with 2.4 mm connectors

Mechanical calibration kits

- **85056A** standard: DC to 50 GHz.
Includes:
 - 00901-60003 2.4 mm (m) fixed broadband load
 - 00902-60004 2.4 mm (f) fixed broadband load
 - 00915-60003 2.4 mm (m) sliding load
 - 00915-60004 2.4 mm (f) sliding load
 - 85056-60005 2.4 mm (m) to 2.4 mm (m) adapter
 - 85056-60006 2.4 mm (f) to 2.4 mm (f) adapter
 - 85056-60007 2.4 mm (m) to 2.4 mm (f) adapter
 - 85056-60020 2.4 mm (m) short
 - 85056-60021 2.4 mm (f) short
 - 85056-60022 2.4 mm (m) open
 - 85056-60023 2.4 mm (f) open

- **85056D** economy: DC to 50 GHz.
Includes:
 - 00901-60003 2.4 mm (m) fixed broadband load
 - 00902-60004 2.4 mm (f) fixed broadband load
 - 85056-60005 2.4 mm (m) to 2.4 mm (m) adapter
 - 85056-60006 2.4 mm (f) to 2.4 mm (f) adapter
 - 85056-60007 2.4 mm (m) to 2.4 mm (f) adapter
 - 85056-60020 2.4 mm (m) short
 - 85056-60021 2.4 mm (f) short
 - 85056-60022 2.4 mm (m) open
 - 85056-60023 2.4 mm (f) open

Electronic calibration kits

- **N4693A** Microwave ECal: 10 MHz to 50 GHz, 2-ports.
Includes:
 - Option MOF** module with:
 - N4693-60001 2.4 mm (f) to 2.4 mm (m) ECal module
 - Option OOM** module with:
 - N4693-60002 2.4 mm (m) to 2.4 mm (m) ECal module
 - Option OOF** module with:
 - N4693-60003 2.4 mm (f) to 2.4 mm (f) ECal module
 - Option OOA** adds:
 - 85056-60005 2.4 mm (m) to 2.4 mm (m) adapter
 - 85056-60007 2.4 mm (f) to 2.4 mm (f) adapter

Cables

Note: Agilent offers the following 2.4 mm test port cables. Adapters will be necessary when using these cables for 2.92 mm measurements.

- **85133C¹** single, semi-rigid: 2.4 mm (f) to PSC-2.4 mm (f), 81 cm, 32 inches
- **85133D¹** set, semi-rigid:
 - One 2.4 mm (f) to 2.4 mm (m), 53 cm, 21 inches, p/n 85133-60001
 - One 2.4 mm (f) to 2.4 mm (f), 53 cm, 21 inches, p/n 85133-60002
- **85133E¹** single, flexible: 2.4 mm (f) to PSC-2.4 mm (f), 97 cm, 38 inches
- **85133F¹** set, flexible:
 - One 2.4 mm (f) to 2.4 mm (f), 63 cm, 25 inches, p/n 85133-60016
 - One 2.4 mm (f) to 2.4 mm (m), 63 cm, 25 inches, p/n 85133-60017
- **85133G¹** Single, semi-rigid: 2.4 mm (f) to 2.4 mm (m), 53 cm, 21 inches
- **85133H¹** Single, flexible: 2.4 mm (f) to 2.4 mm (m), 63 cm, 25 inches
- **N4421A-B20** Set of 4, flexible: 2.4 mm (f) to 2.4 mm (m), 91.4 cm, 36 inches

1. Special rugged female connector specifically for connecting to the network analyzer test port, but does not mate with a standard male connector.
2. Special rugged female connector specifically for connecting to the network analyzers NMD 2.4 mm test port, but does not mate with standard 2.4 mm male connector

Adapter set

- **85130F** 2.4 mm¹ to 3.5 mm
- **85130F** 2.5 mm¹ to 3.5 mm
- **85130G** 2.4 mm¹ to 2.4 mm

For devices with K connectors (2.92 mm)

Mechanical calibration kits

- **85056KE01** DC to 40 GHz
For use with user supplied 2.9 mm test port cables. 2.92 mm (K connector) calibration kit with fixed and sliding loads. The Agilent 85056KE01 calibration kit is an ordering convenience to allow the pass through ordering from Agilent Technologies, Inc. for the Maury 8770C47 calibration kit.

- **85056KE02** DC to 40 GHz
For use with user supplied 2.92 mm test ports cables. 2.92 mm (K connector) calibration kit with fixed loads only. The Agilent 85056KE02 calibration kit is an ordering convenience to allow the pass through ordering from Agilent Technologies, Inc. for the Maury 8770D47 calibration kit.

The 85056KE01 and 85056KE02 contains one NMD 2.4 mm² (f) to 2.92 mm (f) and one NMD 2.4 mm² (f) to 2.92 mm (m) test port adapter to adapt the 2.4 mm test ports of the PNA to 2.92 mm. It also supplies 2.92 mm to 2.92 mm in-series adapters (3 adapters) and a PNA Cal Coefficients on a USB stick. Users must supply their own 2.92 mm or K-connector test port cables. Also included is a 2.92 mm torque wrench.

Maury Microwave Terms and Conditions for Warranty and Return apply. Maury Microwave Corp. calibration kits are to be returned directly to Maury Microwave for service, repair, or calibration issues and not to Agilent Technologies. For additional information go to www.maurymicrowave.com.

Agilent Technologies does not guarantee the performance of the Maury calibration kits or the system performance when connected to Agilent Microwave PNA Series network analyzers.

Electronic calibration kits

- **N4692A** Microwave ECal: 10 MHz to 40 GHz, 2-ports.
Includes:
 - Option MOF** module with:
 - N4692-60001 2.92 mm (f) to 2.92 mm (m) ECal module
 - Option OOM** module with:
 - N4692-60002 2.92 mm (m) to 2.92 mm (m) ECal module
 - Option OOF** module with:
 - N4692-60003 2.92 mm (f) to 2.92 mm (f) ECal module
 - Option OOA** adds:
 - N4692-60021 2.92 mm (m) to 2.92 mm (m) adapter
 - N4692-60022 2.92 mm (f) to 2.92 mm (f) adapter

Cables

Note: Agilent offers the following 2.4 mm test port cables. Adapters will be necessary when using these cables for 2.92 mm measurements.

- 85133C**¹ single, semi-rigid: 2.4 mm (f) to PSC-2.4 mm (f), 81 cm, 32 inches
- 85133D**¹ set, semi-rigid:
 - One 2.4 mm (f) to 2.4 mm (m), 53 cm, 21 inches, p/n 85133-60001
 - One 2.4 mm (f) to 2.4 mm (f), 53 cm, 21 inches, p/n 85133-60002
- 85133E**¹ single, flexible: 2.4 mm (f) to PSC-2.4 mm (f), 97 cm, 38 inches
- 85133F**¹ set, flexible:
 - One 2.4 mm (f) to 2.4 mm (f), 63 cm, 25 inches, p/n 85133-60016
 - One 2.4 mm (f) to 2.4 mm (m), 63 cm, 25 inches, p/n 85133-60017
- 85133G**¹ Single, semi-rigid: 2.4 mm (f) to 2.4 mm (m), 53 cm, 21 inches
- 85133H**¹ Single, flexible: 2.4 mm (f) to 2.4 mm (m), 63 cm, 25 inches
- N4421A-B20** Set of 4, flexible: 2.4 mm (f) to 2.4 mm (m), 91.4 cm, 36 inches

Adapters

- 11904A** 2.4 mm (m) to 2.92 mm (m)
- 11904B** 2.4 mm (f) to 2.92 mm (f)
- 11904C** 2.4 mm (m) to 2.92 mm (f)
- 11904D** 2.4 mm (f) to 2.92 mm (m)
- 11904S** 2.4 mm to 2.92 mm

Adapter set, contains 4 matched adapters

1. Special rugged female connector specifically for connecting to the network analyzer test port, but does not mate with a standard male connector.

For devices with 3.5 mm or SMA connectors

Mechanical calibration kits

- **85052B** standard: DC to 26.5 GHz.
Includes:
00902-60003 3.5 mm (m) fixed load
00902-60004 3.5 mm (f) fixed load
00911-60019 3.5 mm (m) sliding load
00911-60020 3.5 mm (f) sliding load
85052-60006 3.5 mm (m) short
85052-60007 3.5 mm (f) short
85052-60008 3.5 mm (m) open
85052-60009 3.5 mm (f) open
85052-60012 3.5 mm (f) to 3.5 mm (f) adapter
85052-60013 3.5 mm (f) to 3.5 mm (m) adapter
85052-60014 3.5 mm (m) to 3.5 mm (m) adapter
- **85052C** precision TRL: DC to 26.5 GHz.
Includes:
00902-60003 3.5 mm (m) fixed load
00902-60004 3.5 mm (f) fixed load
85052-60006 3.5 mm (m) short
85052-60007 3.5 mm (f) short
85052-60008 3.5 mm (m) open
85052-60009 3.5 mm (f) open
85052-60032 3.5 mm (f) to 3.5 mm (f) adapter
85052-60033 3.5 mm (m) to 3.5 mm (m) adapter
85052-60034 3.5 mm (f) to 3.5 mm (m) adapter
85052-60035 3.5 mm short TRL line
85052-60036 3.5 mm long TRL line

- **85052D** economy: DC to 26.5 GHz.
Includes:
00902-60003 3.5 mm (m) fixed load
00902-60004 3.5 mm (f) fixed load
85052-60006 3.5 mm (m) short
85052-60007 3.5 mm (f) short
85052-60008 3.5 mm (m) open
85052-60009 3.5 mm (f) open
85052-60012 3.5 mm (f) to 3.5 mm (f) adapter
85052-60013 3.5 mm (f) to 3.5 mm (m) adapter
85052-60014 3.5 mm (m) to 3.5 mm (m) adapter

Electronic calibration kits

- **85093C** RF ECal: 300 kHz to 9 GHz, 2-ports
Standard module includes
Option M0F with:
85093-60008 3.5 mm (f) to 3.5 mm (m) ECal module
Option 00F module with:
85093-60010 3.5 mm (f) to 3.5 mm (f) ECal module
Option 00M module with:
85093-60009 3.5 mm (m) to 3.5 mm (m) ECal module
Option 00A adds:
85052-60012 3.5 mm (m) to 3.5 mm (m) adapter
85052-60014 3.5 mm (f) to 3.5 mm (f) adapter

1. Special rugged female connector specifically for connecting to the network analyzer test port, but does not mate with a standard male connector.
2. For use with E8362C.

85093C-xxx mixed-connector options:

Port A option			Port B option					
Type	(f)	(m)	Type	(f)	(m)	Type	(f)	(m)
3.5 mm	101	102	Type-N 50 ohm	203	204	7-16	205	206

- **N4431B** Microwave ECal: 300 kHz to 13.5 GHz, 4-ports.
Includes:
Option 010 module with:
N4431-60006 4 x 3.5 mm (f) ECal module

N4431B-xxx mixed-connector options:

Connector type	Port A option	Port B option	Port C option	Port D option
3.5 mm (f)	101	201	301	401
3.5 mm (m)	102	202	302	402
Type-N 50 ohm (f)	103	203	303	403
Type-N 50 ohm (m)	104	204	304	404
7-16 (f)	105	205	305	405
7-16 (m)	106	206	306	406

- **N4433A** Microwave ECal: 300 kHz to 20 GHz, 4-ports.
Includes:
Option 010 module with:
N4433-60003 4 x 3.5 mm (f) ECal module

N4433A-xxx mixed-connector options:

Connector type	Port A option	Port B option	Port C option	Port D option
3.5 mm (f)	101	201	301	401
3.5 mm (m)	102	202	302	402

- **N4691B** Microwave ECal: 300 kHz to 26.5 GHz, 2-ports.
Includes:
Option M0F module with:
N4691-60001 3.5 mm (f) to 3.5 mm (m) ECal module
Option 00M module with:
N4691-60002 3.5 mm (m) to 3.5 mm (m) ECal module
Option 00F module with:
N4691-60003 3.5 mm (f) to 3.5 mm (f) ECal module
Option 00A adds:
85052-60012 3.5 mm (m) to 3.5 mm (m) adapter
85052-60014 3.5 mm (f) to 3.5 mm (f) adapter

Cables

- **85131C¹** single, semi-rigid: 3.5 mm (f) to PSC-3.5 mm (f), 81 cm, 32 inches²
- **85131D¹** set, semi-rigid:
One 3.5 mm (f) to 3.5 mm (m), 53 cm, 21 inches, p/n 85131-60009
One 3.5 mm (f) to PSC-3.5 mm (f), 53 cm, 21 inches, p/n 85131-60010
- **85131E¹** single, flexible: 3.5 mm (f) to PSC-3.5 mm (f), 96.5 cm, 38 inches²
- **85131F¹** set, flexible:
One 3.5 mm (f) to 3.5 mm (m), 62.2 cm, 24.5 inches, p/n 85131-60012
One 3.5 mm (f) to PSC-3.5 mm (f), 62.2 cm, 24.5 inches, p/n 85131-60013

- 85131G¹** single, semi-rigid: 3.5 mm (f) to 3.5 mm (m), 53 cm, 21 inches
- 85131H¹** single, flexible: 3.5 mm (f) to 3.5 mm (m), 62.2 cm, 24.5 inches
- 85134C¹** single, semi-rigid: PSC-3.5 mm (f) to 2.4 mm (f), 81 cm, 32 inches
- 85134D¹** set, semi-rigid:
 - One 2.4 mm (f) to PSC-3.5 mm (f), 53 cm, 21 inches, p/n 85134-60002
 - One 2.4 mm (f) to PSC-3.5 mm (m), 53 cm, 21 inches, p/n 85134-60001
- 85134E¹** single, flexible: PSC-3.5 mm (f) to 2.4 mm (f), 96 cm, 38 inches
- 85134F¹** set, flexible:
 - One 2.4 mm (f) to PSC-3.5 mm (f), 53 cm, 21 inches, p/n 85134-60004
 - One 2.4 mm (f) to PSC-3.5 mm (m), 53 cm, 21 inches, p/n 85134-60003
- 85134G¹** single, semi-rigid: 2.4 mm (f) to PSC-3.5 mm (m), 53 cm, 21 inches
- 85134H¹** single, flexible: 2.4 mm (f) to PSC-3.5 mm (m), 53 cm, 21 inches
- N4419A-B20** set of 4, flexible: 3.5 mm (m) to 3.5 mm (f), 91.4 cm, 36 inches
- Z5623A-B20** set of 4, flexible: 3.5 mm (m) to 3.5 mm (m), 91.4 cm, 36 inches (phase-matched)

Adapter sets

- 85130D** 3.5 mm¹ to 3.5 mm

For devices with Type-N connectors

Mechanical calibration kits

- 85054B** standard: DC to 18 GHz.
 - Includes:
 - 00909-60011 Type-N (m) fixed lowband load
 - 00909-60012 Type-N (f) fixed lowband load
 - 85054-60025 Type-N (m) short
 - 85054-60026 Type-N (f) short
 - 85054-60027 Type-N (m) open
 - 85054-60028 Type-N (f) open
 - 85054-60031 Type-N (f) to 7mm adapter
 - 85054-60032 Type-N (m) to 7mm adapter
 - 85054-60037 Type-N (f) to Type-N (f) adapter
 - 85054-60038 Type-N (m) to Type-N (m) adapter
 - 85054-80010 Type-N (f) sliding load
 - 85054-80009 Type-N (m) sliding load
 - 85054-60050 Type-N (f) connector gage
 - 85054-60052 Type-N (f) gage master
 - 85054-60051 Type-N (m) connector gage
 - 85054-60053 Type-N (m) gage master
- 85054D** economy: DC to 18 GHz.
 - Includes:
 - 85054-60025 Type-N (m) short
 - 85054-60026 Type-N (f) short
 - 85054-60027 Type-N (m) open

- 85054-60028 Type-N (f) open
- 85054-60031 Type-N (f) to 7mm adapter
- 85054-60032 Type-N (m) to 7mm adapter
- 85054-60037 Type-N (f) to Type-N (f) adapter
- 85054-60038 Type-N (m) to Type-N (m) adapter
- 85054-60046 Type-N (m) fixed load
- 85054-60047 Type-N (f) fixed load

Adapter sets

- 85130C** 3.5 mm² to Type-N

Electronic calibration kits

- N4431B** Microwave ECal: 300 kHz to 13.5 GHz, 4-ports.
 - Includes:
 - Option 020** module with:
 - N4431-60007 4 x Type-N (f) ECal module

N4431B-xxx mixed-connector options:

Connector type	Port A option	Port B option	Port C option	Port D option
3.5 mm (f)	101	201	301	401
3.5 mm (m)	102	202	302	402
Type-N 50 ohm (f)	103	203	303	403
Type-N 50 ohm (m)	104	204	304	404
7-16 (f) ¹	105	205	305	405
7-16 (m) ¹	106	206	306	406

- N4432A** Microwave ECal: 300 kHz to 18 GHz, 4-ports.
 - Includes:
 - Option 020** module with:
 - N4432-60003 4 x Type-N (f) ECal module

N4432A-xxx mixed-connector options:

Connector type	Port A option	Port B option	Port C option	Port D option
3.5 mm (f)	101	201	301	401
3.5 mm (m)	102	202	302	402
Type-N 50 ohm (f)	103	203	303	403
Type-N 50 ohm (m)	104	204	304	404

- N4690B** Microwave ECal: 300 kHz to 18 GHz, 2-ports.
 - Includes:
 - Option MOF** module with:
 - N4690-60001 Type-N (f) to Type-N (m) ECal module
 - Option O0M** module with:
 - N4690-60002 Type-N (m) to Type-N (m) ECal module
 - Option O0F** module with:
 - N4690-60003 Type-N (f) to Type-N (f) ECal module
 - Option 00A** adds:
 - 85054-60037 Type-N (f) to Type-N (f) adapter
 - 85054-60038 Type-N (m) to Type-N (m) adapter

Cables ²

Use the test port cables recommended for devices with 7 mm connectors, and 7 mm to Type-N adapters that are from the 85054B/D Type-N calibration kit (see 7 mm connector section).

1. Special rugged female connector specifically for connecting to the network analyzer test port, but does not mate with a standard male connector.
 2. For use with E8362C.

For devices with 7 mm connectors

Mechanical calibration kits

- 85050B** standard: DC to 18 GHz.
Includes:
 - 00909-60008 7 mm coax termination
 - 85050-60006 7 mm fixed broadband load
 - 85050-80007 7 mm short
 - 85050-80010 7 mm open
 - 85050-80011 7 mm sliding load
- 85050C** precision TRL: DC to 18 GHz.
Includes:
 - 00909-60008 7 mm coax termination
 - 85050-60003 7 mm to 7 mm airline
 - 85050-60005 7 mm to 7 mm TRL adapter
 - 85050-60006 7 mm fixed broadband load
 - 85050-80008 7 mm short
 - 85050-80009 7 mm short collet
 - 85050-80010 7 mm open
- 85050D** economy: DC to 18 GHz.
Includes:
 - 85050-60006 7 mm fixed broadband load
 - 85050-80007 7 mm short
 - 85050-80010 7 mm open

Electronic calibration kits

- N4696B** Microwave ECal: 300 kHz to 18 GHz, 2-ports, 7mm to 7mm Microwave module

Cables¹

- 85132C** single, semi-rigid: 7 mm to 3.5 mm (f), 81 cm, 32 inches²
- 85132D** set, semi-rigid: two 3.5 mm (f) to 7 mm cables, 53 cm each, 21 inches each², p/n 85132-60003
- 85132E** single, flexible: 7 mm to 3.5 mm (f), 97.2 cm, 38.25 inches²
- 85132F** set, flexible: two 3.5 mm (f) to 7 mm cables, 62.9 cm each, 24.75 inches each², p/n 85132-60004
- 85135C** single, semi-rigid: 7 mm to 2.4 mm (f), 81 cm, 32 inches
- 85135D** set, semi-rigid: two 2.4 mm (f) to 7 mm cables, 53 cm each, 21 inches each, p/n 85135-60001
- 85135E** single, flexible: 7 mm to 2.4 mm (f), 96 cm, 38 inches
- 85135F** set, flexible: two 2.4 mm (f) to 7 mm cables, 53 cm each, 21 inches each, p/n 85135-60002

Adapter sets

- 85130E** 2.4 mm¹ to 7 mm

For devices with waveguide

Mechanical calibration kits

X Band

- X11644A** standard, WR-90: 8.2 to 12.4 GHz. Includes:
 - 00896-60008 X-band standard section
 - 00910-60003 X-band termination
 - 11644-20018 X-band short
 - 11644-20021 X-band shim
- 85132F** cable set (set, flexible 7 mm to 3.5 mm, 62.9 cm each, 24.75 inches each²)
- 85135F** cable set (set, flexible, 7 mm to 2.4 mm, 53 cm each, 21 inches each)
- X281C** adapter (included in calibration kit): WR-90 to 7 mm

P Band

- P11644A** standard, WR-62: 12.4 to 18 GHz.
Includes:
 - 00896-60007 P-band standard section
 - 00910-60002 P-band termination
 - 11644-20017 P-band short
 - 11644-20020 P-band shim
- 85132F** cable set (set, flexible, 7 mm to 3.5 mm, 62.9 cm each, 24.75 inches each²)
- 85135F** cable set (set, flexible, 7 mm to 2.4 mm, 53 cm each, 21 inches each)
- P281C** adapter (included in calibration kit): WR-62 to 7 mm

K Band

- K11644A** standard, WR-42: 18 to 26.5 GHz.
Includes:
 - 00896-60006 K-band standard section
 - 00910-60001 K-band termination
 - 11644-20016 K-band short
 - 11644-20019 K-band shim
- 85134F** cable set (set, flexible, 3.5 mm to 2.4 mm, 53 cm each, 21 inches each)
- K281C** adapter (included in calibration kit): WR-42 to 3.5 mm (f)
Option 012 WR-42 to 3.5 mm (m)

R Band

- R11644A** standard, WR-28: 26.5 to 40 GHz.
Includes:
 - 00914-20028 R-band termination
 - 11644-20005 R-band short
 - 11644-20003 R-band shim
 - 11644-60001 R-band 10 cm straight waveguide
 - 11644-60016 R-band 5 cm straight waveguide
- 85133F** cable set (set, flexible, 2.4 mm, 53 cm each, 21 inches each)
- R281A** adapter (2.4 mm (f) to WR-28 waveguide adapter)
- R281B** adapter (2.4 mm (m) to WR-28 waveguide adapter)

Q Band

Q11644A standard, WR-22: 33 to 50 GHz.

Includes:

- 11644-60005 Q-band termination
- 11644-20004 Q-band short
- 11644-20001 Q-band shim

11644-60002 Q-band 10 cm straight waveguide

11644-60017 Q-band 5 cm straight waveguide

- 85133F** cable set (set, flexible, 2.4 mm, 53 cm each, 21 inches each)
- Q281A** adapter (2.4 mm (f) to WR-22 waveguide adapter)
- Q281B** adapter (2.4 mm (m) to WR-22 waveguide adapter)

U Band

U11644A standard, WR-19: 40 to 60 GHz.

Includes:

- 11644-60006 U-band termination
- 11644-20004 U-band short
- 11644-20002 U-band shim
- 11644-60003 U-band 10 cm straight waveguide
- 11644-60018 U-band 5 cm straight waveguide

V Band

V11644A standard, WR-15: 50 to 75 GHz.

Includes:

- 11644-60025 V-band termination
- 11644-20015 V-band short
- 11644-20013 V-band shim
- 11644-60012 V-band standard section

Verification kits

All Agilent verification kits include:

- precision Z_0 airline or match thru
- mismatched airline or mismatch thru
- fixed attenuators
- traceable measured data and uncertainties

85053B 300 kHz to 26.5 GHz 3.5 mm kit

Includes attenuators, airline and mismatch airline with data on a 3.5-inch disk for use in confirming accuracy enhanced system measurement performance, traceable to national standards. Test procedure is provided in the service manual.

85055A 300 kHz to 18 GHz Type-N kit

Includes attenuators, airline and mismatch airline with data on a 3.5-inch disk for use in confirming accuracy enhanced system measurement performance, traceable to national standards. Test procedure is provided in the service manual.

85057B 45 MHz to 50 GHz 2.4 mm kit

Includes attenuators, airline and mismatch airline with data on a 3.5-inch disk for use in confirming accuracy enhanced system measurement performance, traceable to national standards. Test procedure is provided in the service manual.

85058V 45 MHz to 67 GHz 1.85 mm kit

Includes attenuators, match thru and mismatch thru with data on a 3.5-inch disk for use in confirming accuracy enhanced system measurement performance, traceable to national standards. Test procedure is provided in the service manual.

General Accessories

USB

- N4688A** CD-ROM drive
Provides an external read/write CD-ROM drive with a USB cable.
- N4689A** USB hub
Provides a USB hub for connecting additional USB peripherals.

Hard drive¹

- N8981A** spare hard drive with mounting cradle
For E836xA/B and N5230A.
- N8982A** spare hard drive with mounting cradle
For E836xC and N5230C.
- N5242-60035** spare hard drive
For N5242A with 1.6 GHz Pentium M CPU.
- N5242-60037** spare CPU board with hard drive
For N5242A with 1.6 GHz Pentium M CPU.
- N5242-60044** spare hard drive with mounting cradle
For N524xA with 2.0 GHz Core 2 Duo CPU.

Probe

- 85024A** high-frequency probe
Provides high-impedance in-circuit test capability from 300 kHz to 3 GHz.

Power meters and sensors²

Recommended for self support, adjustments and performance tests to verify proper instrument operation.

- U2000A** USB power sensor, 10 MHz to 18 GHz
- U2001A** USB power sensor, 10 MHz to 6 GHz
- U2002A** USB power sensor, 50 MHz to 24 GHz
- U2004A** USB power sensor, 9 kHz to 6 GHz
- E4418B** single-channel power meter
- E4419B** dual-channel power meter
- 8481B** power sensor, 10 MHz to 18 GHz, Type-N (m), 25 W
- 8481A** power sensor, 10 MHz to 18 GHz, Type-N (m), 100 mW
- 8485A** power sensor, 50 MHz to 26.5 GHz, APC-3.5 mm (m), 100 mW
- 8487A** power sensor, 50 MHz to 50 GHz, 2.4 mm, 300 mW
- 8487D** power sensor, 50 MHz to 50 GHz, 2.4 mm, 100 mW
- R8486A** power sensor, 26 GHz to 40 GHz, waveguide flange UG-599/U, 100 mW
- Q8486A** power sensor, 33 GHz to 50 GHz, waveguide flange UG-383/U, 100 mW
- U8486A** power sensor, 50 GHz to 75 GHz, waveguide flange UG-385/U, 200 mW avg
- E4412A** CW power sensor, 10 MHz to 18 GHz, Type-N (m), 200 mW
- E4413A** CW power sensor, 50 MHz to 26.5 GHz, 3.5 mm, 200 mW

Amplifiers

- 83006A** power amplifier, 10 MHz to 26.5 GHz, 20 dB gain, power out: +18 dBm to 10 GHz or +16 dBm to 20 GHz or +14 dBm to 26.5 GHz
- 83017A** power amplifier, 50 MHz to 26.5 GHz, 25 dB gain, power out: +20 dBm to 20 GHz, or +15 dBm to 26.5 GHz
- 83018A** power amplifier, 2 to 26.5 GHz, 27 dB gain to 20 GHz or 23 dB to 26.5 GHz, power out: +24 dBm to 20 GHz or +21 dBm to 26.5 GHz
- 83020A** power amplifier, 2 to 26.5 GHz, 30 dB gain to 20 GHz or 27 dB to 26.5 GHz, power out: +30 dBm to 20 GHz or +26 dBm to 26.5 GHz
- 83050A** power amplifier, 2 to 50 GHz, 23 dB gain, power out: +20 dBm to 40 GHz or +17 dBm to 50 GHz
- 83051A** power amplifier, 45 MHz to 50 GHz, 23 dB gain power out: +12 dBm to 45 GHz or +10 dBm to 50 GHz

Couplers

- 87300B** coaxial coupler, 1 to 20 GHz, SMA (f), 10 dB coupling
- 87300C** coaxial coupler, 1 to 26.5 GHz, 3.5 mm (f), 10 dB coupling
- 87301B** coaxial coupler, 10 to 46 GHz, 2.92 mm (f), 10 dB coupling
- 87301D** coaxial coupler, 1 to 40 GHz, 2.4 mm (f) or optional 2.92 mm (f), 13 dB coupling
- 87301E** coaxial coupler, 2 to 50 GHz, 2.4 mm (f), 10 dB coupling
- 87310B** 90 ° coaxial coupler, 1 to 18 GHz, SMA (f), 3 dB coupling

Equipment rack accessories

- E3663AC** Rail kit
- 5063-9217** Rack mount kit, for use without handles (included with Option 1CM)
- 5063-9205** Front handle kit³
- 5063-9224** Rack mount kit with handles³
- 5063-9237** Rack mount kit, for use with standard supplied handles (included with Option 1CP)³

Monitors

VGA-compatible monitor

Printers

USB, LAN, parallel or serial printers with Microsoft® Windows® printer driver

Interface cables

Choose the appropriate cables to connect each peripheral to the network analyzer.

- 10833A** GPIB cable, 1.0 m (3.3 ft)
- 10833B** GPIB cable, 2.0 m (6.6 ft)
- 10833D** GPIB cable, 0.5 m (1.6 ft)
- 82357B** GPIB to USB interface

1. For more information on hard drive, refer to na.tm.agilent.com/pna/hdnumbers.html

2. For the latest guide to power meters and power sensors, refer to the Agilent web site: www.agilent.com/find/powermeters

3. Front handles and Option 1CP (rack mount with handles) are not available for the N5242A.

Applications

Material measurements

85070E High-Temperature Dielectric Probe Kit

The 85070E enables measurements of the dielectric properties of materials quickly and conveniently. Measurements made with this probe are nondestructive and require no sample preparation. The dielectric probe is well suited for measurements of liquid, semisolid and flat solid materials. Measurement results can be viewed in a variety of formats (ϵ'_r , ϵ''_r , $\tan \delta$ or Cole-Cole). The supplied software can be run in the PNA analyzer or on a PC.

85071E Materials Measurement Software

The 85071E materials measurement software calculates the permittivity and permeability of material samples placed in a coaxial airline or a rectangular waveguide. The measurement technique works well for solid materials that can be machined to fit precisely inside a transmission line. Measurement results can be viewed in a variety of formats (ϵ'_r , ϵ''_r , μ'_r , μ''_r , $\tan \delta$, or Cole-Cole μ). The software can be run in the PNA analyzer or on a PC.

Z5623AH87 Pulsed S-parameter test set, 1 to 50 GHz

Includes two pin switches for bi-directional (forward and reverse) pulsed-RF stimulus. It does not include internal amplifiers, but has front panel access loops for switching in external amplifiers to boost port power in both directions.

Pulsed measurements¹

The pulsed RF measurement capability (Option H08) and IF access (Option H11), are recommended for pulsed measurements with the PNA Series.

Pulse/pattern generators

Recommended to provide pulse signals and timing to the pulsed S-parameter test set and MW PNA

81104A Pulse/pattern generator, 80 MHz, single-/dual-channel with one or two Agilent 81105A output modules.

81110A Pulse/pattern generator, 165 MHz, single-/dual-channel with one or two Agilent 81111A output modules.

Note: Each pulse/pattern generator must be ordered with its associated output modules depending on the measurement configuration.

Z5623AH84 Pulsed S-parameter test set, 2 to 40 GHz

Includes two pin switches for bi-directional (forward and reverse) pulsed-RF stimulus, and two directional couplers for the reference channels. It does not include internal amplifiers, but has front panel access loops for switching in external amplifiers to boost port power in both directions.

Z5623AH86 Pulsed S-parameter test set, 2 to 40 GHz

Includes one pin switch to modulate the analyzer's internal source in the forward direction, and one directional coupler for the reference channel. It does not include internal amplifiers, but has front panel access loops for switching in an external amplifier to boost port power.

1. For more details regarding pulsed measurement configurations with the PNA Series, refer to Agilent's Web site (www.agilent.com/find/pna) to download a copy of the *Microwave PNA Series Network Analyzer Configuration Guide for Pulsed Measurements*, literature number 5989-7913EN.



Agilent Email Updates

www.agilent.com/find/emailupdates
Get the latest information on the products and applications you select.



www.lxistandard.org
LXI is the LAN-based successor to GPIB, providing faster, more efficient connectivity. Agilent is a founding member of the LXI consortium.

Agilent Channel Partners

www.agilent.com/find/channelpartners

Get the best of both worlds: Agilent's measurement expertise and product breadth, combined with channel partner convenience.

Expand your measurement capabilities with Agilent qualified channel partners

Our channel partners offer accessories and measurement solutions that extend your network analysis capabilities.

For more information about probing equipment and accessories, contact:

Cascade Microtech, Inc
2430 NW 206th Avenue
Beaverton, Oregon 97006, USA
Toll free telephone: 1-800-550-3279
Telephone: (503) 601-1000
Fax: (503) 601-1002
Web site: www.cascademicrotech.com
E-mail: sales@cmicro.com

Remove all doubt

Our repair and calibration services will get your equipment back to you, performing like new, when promised. You will get full value out of your Agilent equipment throughout its lifetime. Your equipment will be serviced by Agilent-trained technicians using the latest factory calibration procedures, automated repair diagnostics and genuine parts. You will always have the utmost confidence in your measurements. For information regarding self maintenance of this product, please contact your Agilent office.

Agilent offers a wide range of additional expert test and measurement services for your equipment, including initial start-up assistance, onsite education and training, as well as design, system integration, and project management.

For more information on repair and calibration services, go to:

www.agilent.com/find/removealldoubt

Product specifications and descriptions in this document subject to change without notice.

www.agilent.com

For more information on Agilent Technologies' products, applications or services, please contact your local Agilent office.

The complete list is available at:

www.agilent.com/find/contactus

Americas

Canada	(877) 894-4414
Latin America	305 269 7500
United States	(800) 829-4444

Asia Pacific

Australia	1 800 629 485
China	800 810 0189
Hong Kong	800 938 693
India	1 800 112 929
Japan	0120 (421) 345
Korea	080 769 0800
Malaysia	1 800 888 848
Singapore	1 800 375 8100
Taiwan	0800 047 866
Thailand	1 800 226 008

Europe & Middle East

Austria	43 (0) 1 360 277 1571
Belgium	32 (0) 2 404 93 40
Denmark	45 70 13 15 15
Finland	358 (0) 10 855 2100
France	0825 010 700*
Germany	49 (0) 7031 464 6333
Ireland	1890 924 204
Israel	972-3-9288-504/544
Italy	39 02 92 60 8484
Netherlands	31 (0) 20 547 2111
Spain	34 (91) 631 3300
Sweden	0200-88 22 55
Switzerland	0800 80 53 53
United Kingdom	44 (0) 118 9276201

Other European Countries:
www.agilent.com/find/contactus

Revised: October 1, 2009

© Agilent Technologies, Inc. 2009
Printed in USA, November 30, 2009
5989-7606EN

Pentium® is a U.S. registered trademark of Intel Corporation.
Microsoft® and Windows® are registered trademarks of Microsoft Corporation.

