

**Extra Credit**  
**Counter Reset**

You can receive extra credit the third and fourth ¼ of the semester by building a counter reset circuit and/or an AC/DC converter. You can get extra credit on the third quiz, ONE of the experiments for this part of the course (6, 7, 8), OR the third project. The points available are as follows:

<u>Circuit</u>	<u>Points on Experiment</u>	<u>Points on Project 3</u>	<u>Points on Quiz 3</u>
Counter reset	6	3	4

Fill out one sheet for each circuit. YOU MUST do the project as an individual. Your points will be applied towards your grade on an individual basis. You can't get more than 100 points on any one assignment. The circuit is not difficult, so it is unlikely that it will take more than one open shop to build it.

Ground Rules:

- 1) We will provide you with a protoboard.
- 2) The two circuits and some basic instructions are included on the following page.
- 3) Build your circuit using components from your kit. If you do not have a particular component, ask the staff.
- 4) Demonstrate that it generates the appropriate output.
- 5) Have a staff member sign the attached sheet.
- 6) Return the protoboard. (If you are not finished, we will store the board for you and return it when you wish to continue.)
- 7) YOU MUST tell the staff member what you would like to apply the extra credit towards at the time s/he signs the sheet.

Reset Circuit that counts to TEN

The figure below is a circuit that counts to four and then resets.

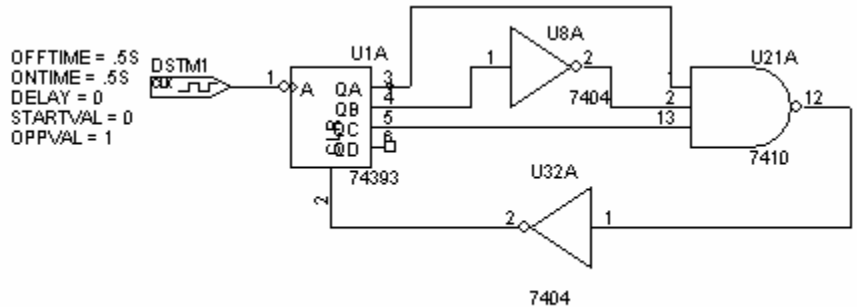

Here is the output from PSpice. You can see that it counts to four before the reset spike (U1A:CLR) resets it. (Observe that the reset actually comes when the counter outputs a five.)

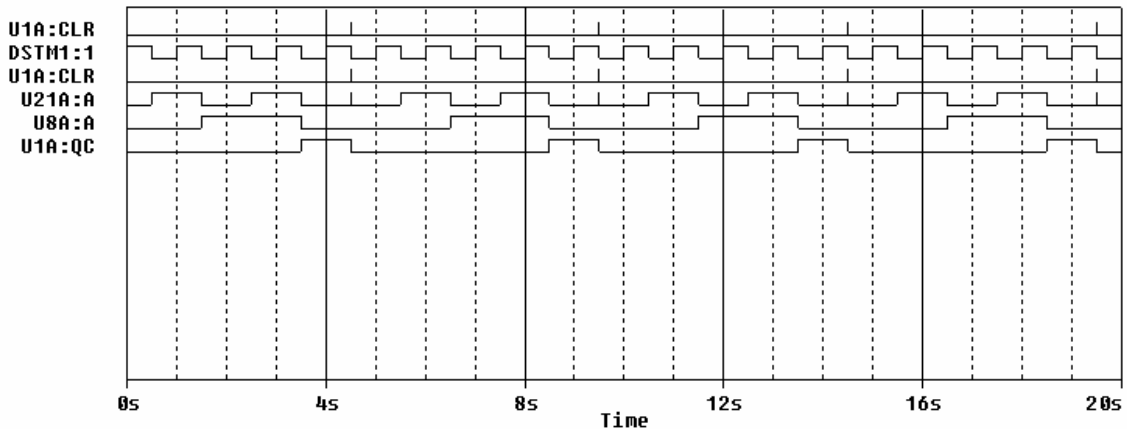

You are to design and build a circuit that counts up to *ten* before it resets.

Use the function generator for the clock and set it at 2 Hz. Also remember to set the clock so that it cycles between 0 and 5V. Place an LED on each of the four outputs from the counter (QA, QB, QC, QD). Have the staff member observe that your circuit counts up to 10 and resets.

Name of student: \_\_\_\_\_

Section \_\_\_\_\_ Group \_\_\_\_\_

Apply Towards: \_\_\_\_\_

Points \_\_\_\_\_ (Points per circuit: quiz = 4, project = 3, experiment = 6)

Protoboard returned \_\_\_\_\_

Staff Signature \_\_\_\_\_