

**ENGR-4300**

**Fall 2007**

**Test 2**

Name \_\_\_\_\_

**Section 1(MR) 2(TF)**  
**(circle one)**

Question I (20 points) \_\_\_\_\_

Question II (20 points) \_\_\_\_\_

Question III (15 points) \_\_\_\_\_

Question IV (20 points) \_\_\_\_\_

Question V (25 points) \_\_\_\_\_

Total (100 points): \_\_\_\_\_

On all questions: SHOW ALL WORK. BEGIN WITH FORMULAS, THEN SUBSTITUTE VALUES AND UNITS. No credit will be given for numbers that appear without justification.

**Question I – Bridges and Damped Sinusoids (20 points)**

One of the most powerful tools we have as engineers is MATLAB, which is especially useful when one does a Simulink model of a system. (The following is provided for completeness. You do not need to know how to work with Simulink to do this problem.) A Simulink model for a cantilever beam is shown below.

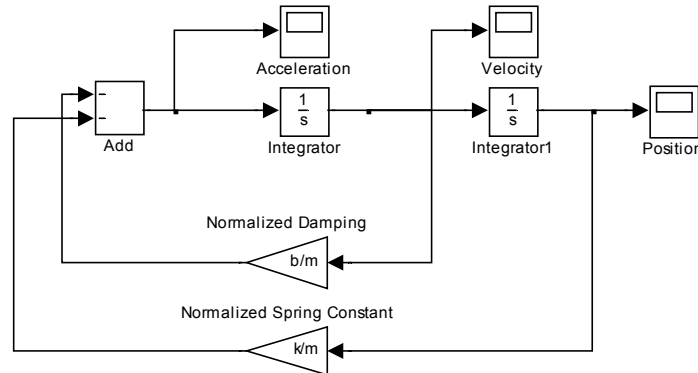

The blocks marked Acceleration, Velocity and Position are 'scopes' that provide data on the given parameter as a function of time. In no particular order, these three plots follow for a particular set of values for  $k$ ,  $b$ , and  $m$  (the spring constant, the damping constant and the mass, respectively).

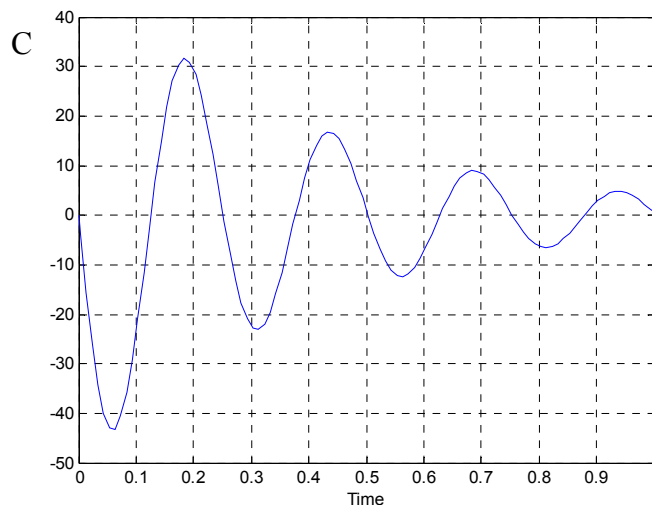
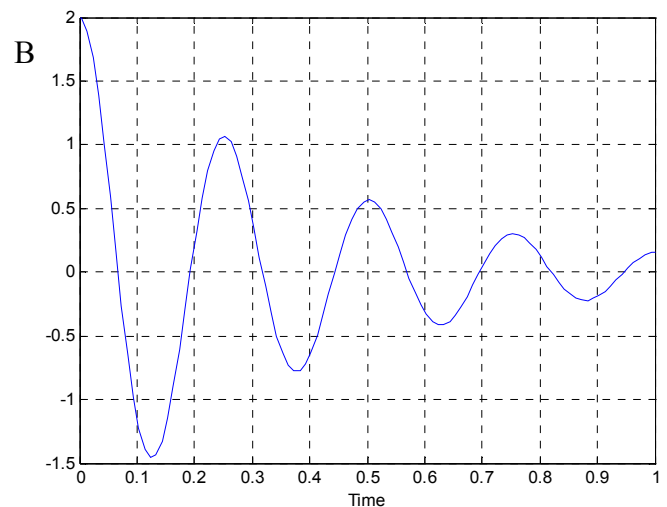
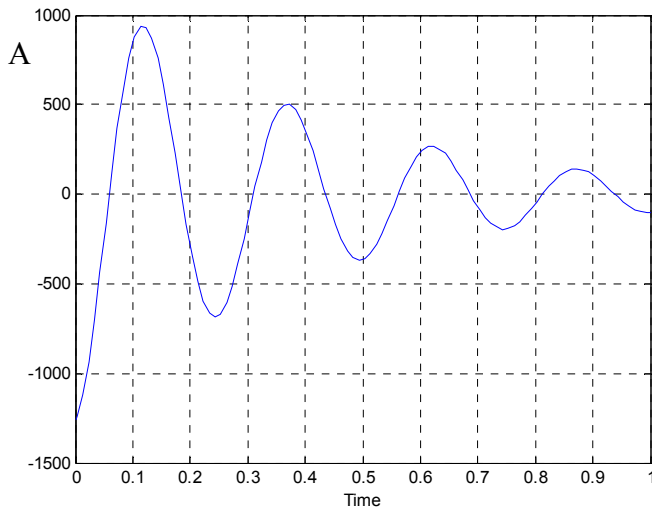

1) (3pt) Identify which plot is **position**, which is **velocity** and which is **acceleration**. From the plots, what are the initial position, velocity and acceleration? Assume SI units (position in meters, velocity in meters per second, acceleration in meters per second squared).

A: \_\_\_\_\_ B: \_\_\_\_\_ C: \_\_\_\_\_

Initial position: \_\_\_\_\_ Initial velocity: \_\_\_\_\_ Initial acceleration: \_\_\_\_\_

2) (6pt) Find the frequency  $f$ , the period  $T$ , and the damping constant  $\alpha$  and then evaluate the mathematical expression for each of the three functions – position, velocity and acceleration of the beam. Generically, these expressions are in the form  $f(t) = F_o e^{-\alpha t} \cos(\omega_o t + \phi_o)$  where  $F_o$ ,  $\alpha$ ,  $\omega_o$  and  $\phi_o$  are constants.

3) (3pt) From these three expressions, determine the mass  $m$ , the damping coefficient  $b$  and the spring constant  $k$  for the cantilever beam being analyzed.

### Question I – Bridges and Damped Sinusoids (continued)

4) (6pt) The position of the beam is measured using a bridge circuit consisting of four identical strain gauges, two on the top of the beam and two on the bottom. They are configured with a DC voltage source as shown below. Note that the nominal resistance of each strain gauge is represented as  $R$  and the change in the resistance of the strain gauge due to the deflection of the beam is  $dR$ . Resistor  $R1$  is 500 Ohms and the voltage source is set to 10V. The voltages observed at each point in the circuit are shown. Since the font is a bit small, they are 10V, 5V, 2.49V and 2.51V. Using this information, determine the values of  $R$  and  $dR$ .

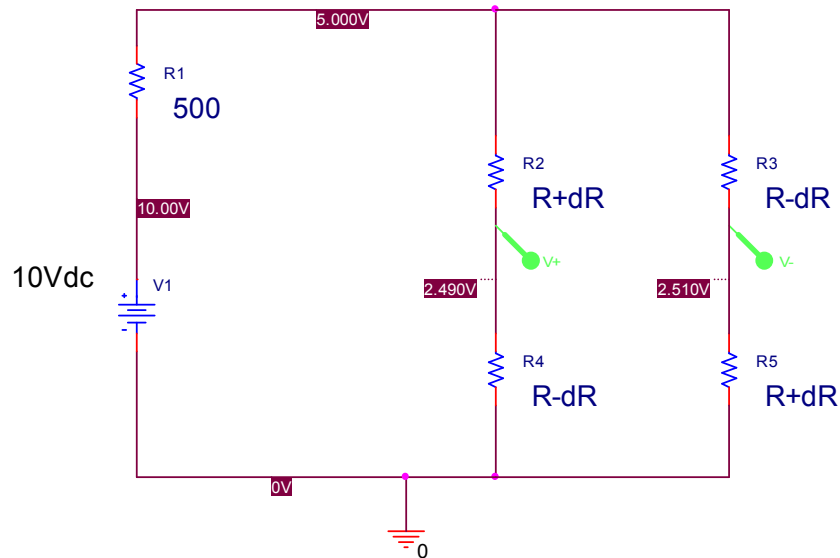

Question I – Bridges and Damped Sinusoids (continued)

5) (2pt) Which of the following can be modeled as cantilever beams? Circle the pictures of the appropriate examples and also show where the cantilever is located.

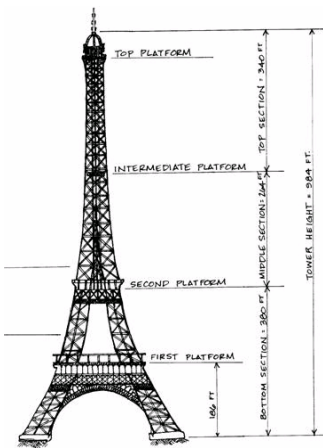

## Question II – Thevenin Equivalents (20 points)

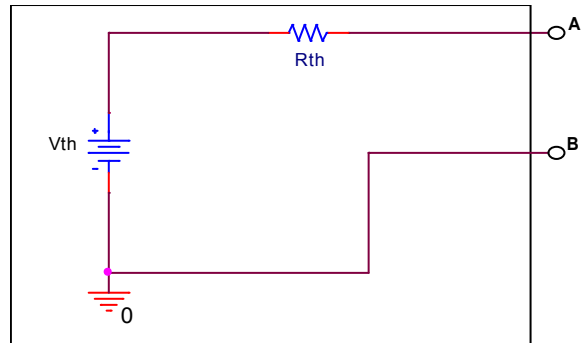
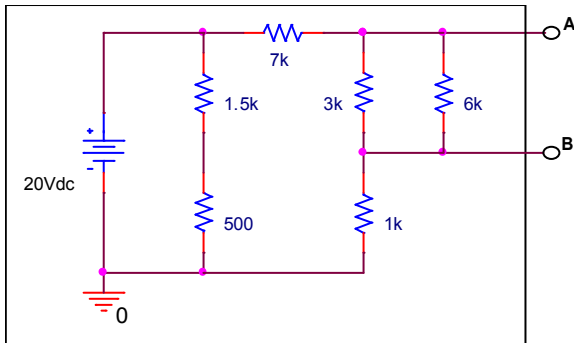

1) (5pt) Find the Thevenin equivalent voltage with respect to A and B for the circuit shown above left.

2) (5pt) Find the Thevenin equivalent resistance with respect to A and B for the circuit shown above left.

3) (3pt) What value load resistance added between A and B will have the largest possible **voltage** across it and how much power will be dissipated in the resistor?

4) (3pt) What value load resistance added between A and B will have the largest possible **current** through it and how much power will be dissipated in the resistor?

5) (4pt) If the DC voltage source is replaced with an AC source and a  $1\ \mu\text{F}$  capacitor is placed across A and B, what is the corner frequency (in radians/s) of the resultant RC filter? Is it a HPF or a LPF?

Question III – Op-Amp Applications (15 points)

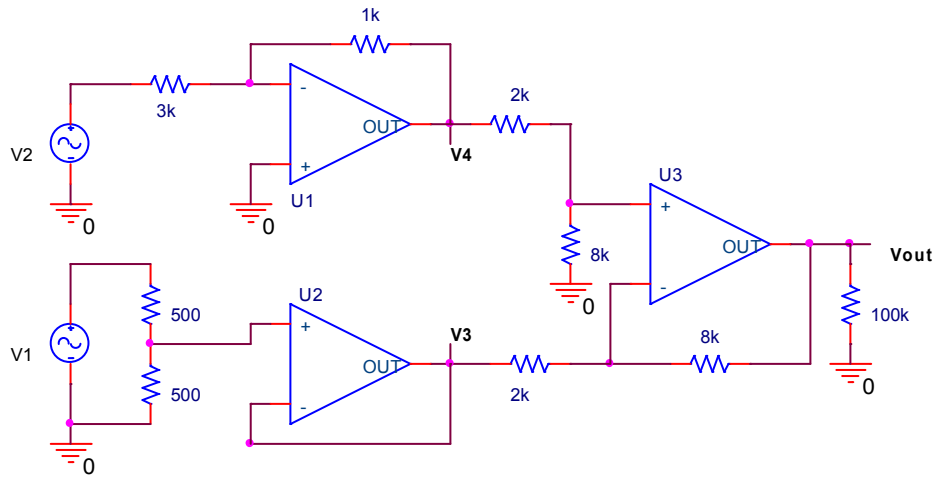

Assume that  $\pm 9$  Volt power supplies have been properly connected to all three op-amps in the circuit above.

1) (3pt) The circuit has 3 op-amps labeled as U1, U2, and U3. State what the op-amp circuit is for each. Choices are: 1. Follower/Buffer, 2. Inverting Amp, 3. Non-inverting Amp, 4. Differentiator, 5. Integrator, 6. Adding (Mixing) Amp, 7. Difference (Differential) Amp.

U1 Circuit: \_\_\_\_\_ U2 Circuit: \_\_\_\_\_ U3 Circuit: \_\_\_\_\_

2) (4pt) Determine the voltage, relative to ground, at points V3 and V4 as functions of V1 and V2.

a) Voltage at point V3:

b) Voltage at point V4:

**Question III – Op-Amp Applications (continued)**

3) (2pt) Determine the output voltage,  $V_{out}$ , as a function of  $V_3$  and  $V_4$ .

4) (2pt) Now find  $V_{out}$  as a function of  $V_1$  and  $V_2$ .

5) (4pt) If  $V_1 = +2$  Volts, how large can  $V_2$  become before the output will no longer match the result given by your answer in 4)?.



## Question IV – Op-Amp Analysis (20 points)

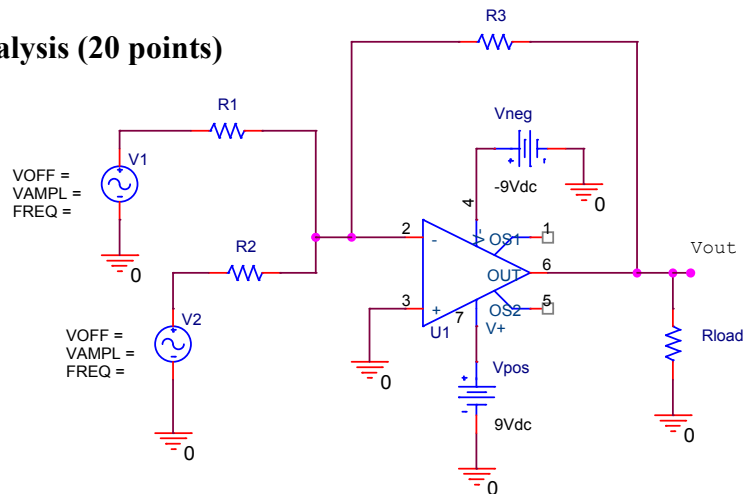

Above is a Capture schematic of an op-amp circuit that you should recognize. Assume the op-amp is ideal.

- 1) (2pt) What type of circuit is it?
  
- 2) (2pt) When assuming that the op-amp is ideal, what are the two golden rules to analyze this circuit?
  
- 3) (4pt) Use these rules to derive an expression for  $V_{out}$  in terms of  $R_1$ ,  $R_2$ ,  $R_3$ ,  $V_1$  and  $V_2$ . (Hint: you may exclude  $R_{load}$ .) Redraw the circuit (Remove the op-amp and draw two circuits: one for the + and one for the – input terminals of the op-amp, **draw currents  $I_1$ ,  $I_2$ , and  $I_3$  through  $R_1$ ,  $R_2$ , and  $R_3$  respectively, on the circuit**).

**Question IV – Op-Amp Analysis (continued)**

4) (4pt) Write equations for the two circuits (use the current relationship).

5) (4pt) Simplify using the golden rules and solve for  $V_{out}$ .

6) (4pt) If  $V_1 = 0.2\text{ V}$ ,  $V_2 = 0.3\text{ V}$ ,  $R_1 = 3\text{ k}\Omega$ ,  $R_2 = 3\text{ k}\Omega$ , and  $R_3 = 12\text{ k}\Omega$ , what is the value of  $V_{out}$  in volts? (Show your work.)

## Question V – Op-Amp Integrators and Differentiators (25 points)

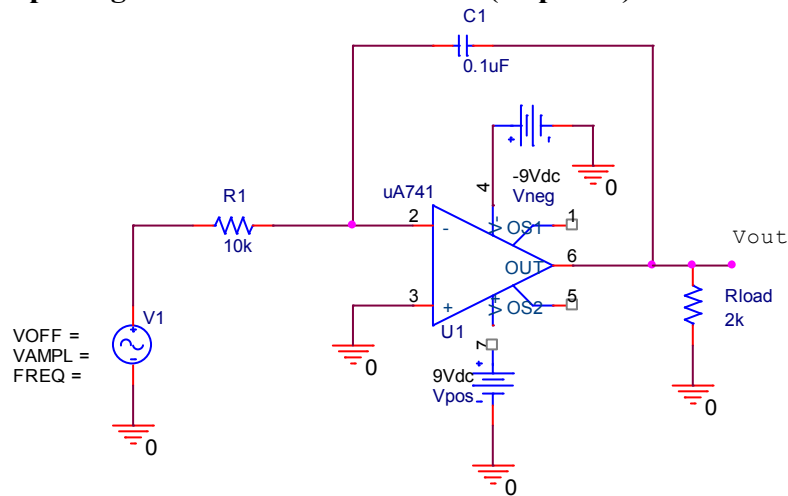

Assume the op-amp in the circuit above is ideal.

1) (1pt) Above is a Capture schematic of an op-amp circuit that you should recognize. What type of circuit is it?

2) (4pt) For this circuit the input is sinusoidal. What is  $H(j\omega)$ , the transfer function, for this circuit?  $H(j\omega) = V_{out}/V_1$ . You must use the component values; don't leave the answer in terms of  $R_1$  or  $C_1$ . Simplify your answer.

3) (4pt) If a 1k resistor is added in parallel with  $C_1$ , what is the corner frequency in Hertz?

4) (1pt) If the input frequency is 10 kHz, will it operate as it should?

## Question V – Op-Amp Integrators and Differentiators (continued)

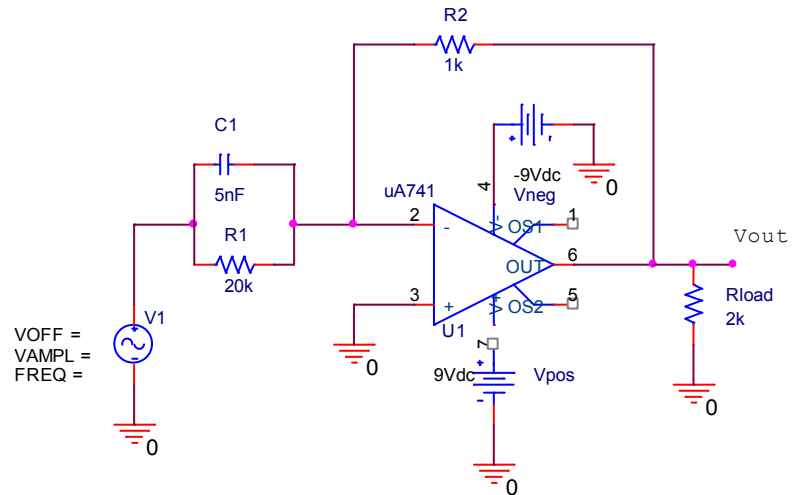

Assume that the input is sinusoidal and we want to find  $H(j\omega)$ , the transfer function, for this circuit. We know that when the non-inverting terminal of an op amp circuit is grounded,  $H(j\omega) = -Z_f/Z_{in}$ .

5) (1pt) Find  $Z_f$  and substitute values for components.

6) (4pt) Find  $Z_{in}$ . Substitute values for the components. Simplify your answer.

7) (4pt) Using 5) and 6) determine the transfer function,  $H(j\omega)$ , for the circuit. Substitute component values. Simplify your answer.

**Question V – Op-Amp Integrators and Differentiators (continued)**

8) (3pt) At high frequency this circuit in 5) acts like a \_\_\_\_\_.  
Fill in the blank using one of the following: a) Inverting Amplifier, b) Non-inverting Amplifier, c) Differential Amplifier, d) Adder, e) Integrator, f) Differentiator, g) none of a thru e.

9) (3pt) Now assume that  $V_{in}$  is a 0.2V DC source. What is  $V_{out}$ ?