

**ENGR-4300**  
**Spring 2007**  
**Test 4B**

Name \_\_\_\_\_

Section \_\_\_\_\_

Question I (23 points) \_\_\_\_\_

Question II (15 points) \_\_\_\_\_

Question III (14 points) \_\_\_\_\_

Question IV (23 points) \_\_\_\_\_

Question V (25 points) \_\_\_\_\_

Total (100 points): \_\_\_\_\_

On all questions: SHOW ALL WORK. BEGIN WITH FORMULAS, THEN SUBSTITUTE VALUES AND UNITS. No credit will be given for numbers that appear without justification.

Question I – Diode Rectifier Circuits (23 points)

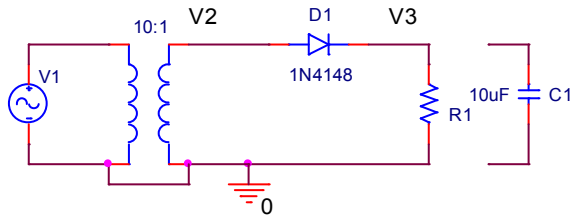

The diagram above shows the application of a diode for performing rectification of the signal from the output of the transformer. The sinusoidal source of voltage (V1) has a  $V_{AMP}=100V$ ,  $V_{OFF}=0.1V$ ,  $FREQ=500Hz$ . Assume that the diode has  $0.7V$  during turn-on. C1 is not connected initially.

1. (6pt) Sketch V2 and V3 (label plots) in the figure below:

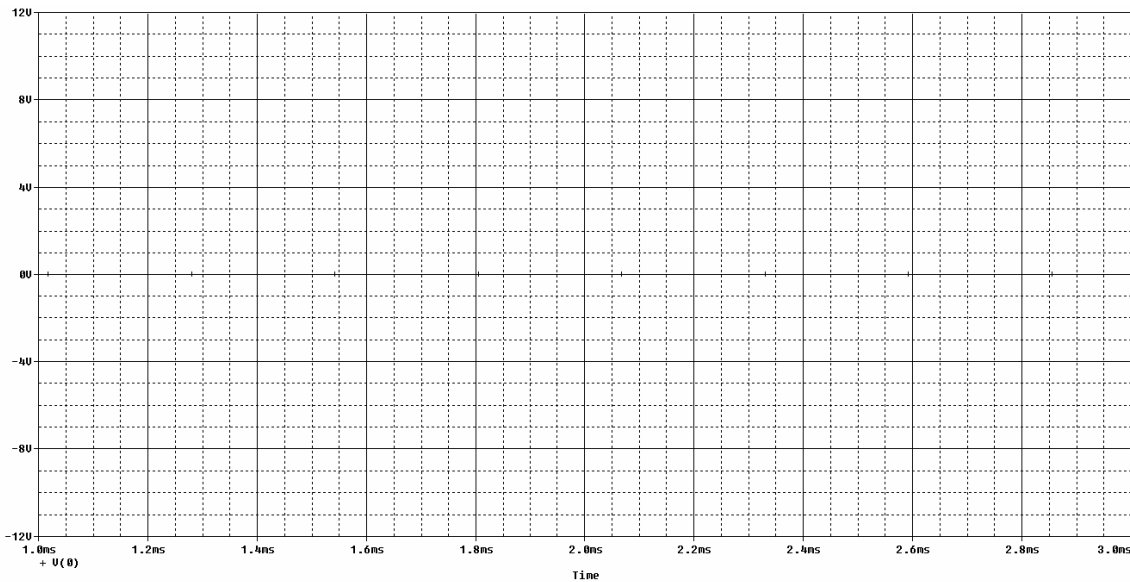

2. (4pt) If the load resistor (R1) has a value of  $2k\Omega$ , what is the maximum and minimum current that will flow through the load?

3. (2pt) What is the value of the offset voltage you would expect to measure at V2?

4. (4pt) If a capacitor C1 is added parallel to R1, show how V3 would be changed by adding the waveform to the plot in 1. and label it  $V_{cap}$ . Only a rough approximation is desired.

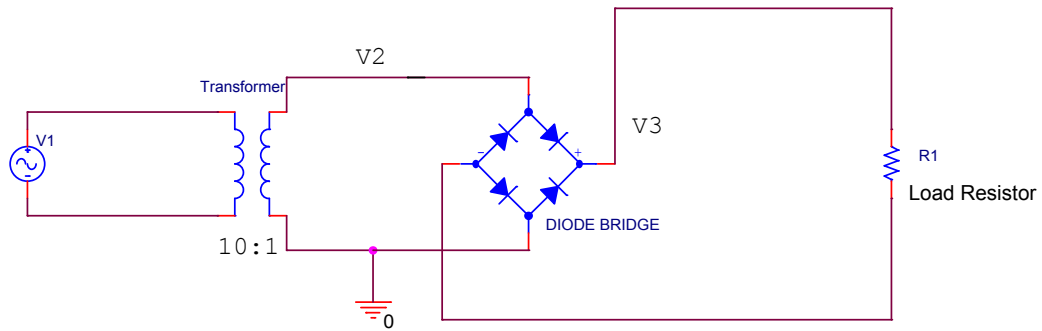

5. (7pt) Now a full wave diode bridge replaces the diode. For this question, assume that the voltage at V2 is a 12V sine wave with no offset and a frequency of 500Hz. Plot V2 and the voltage across the resistor R1.

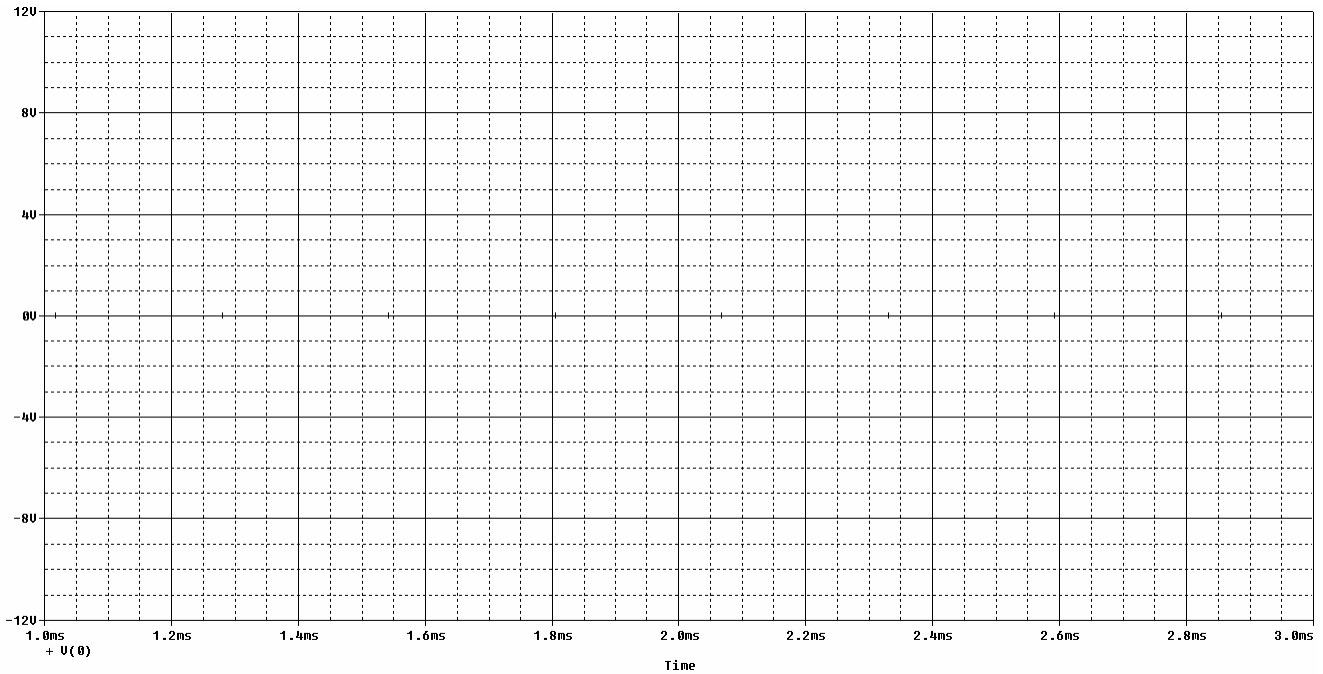

Question II – Zener Diode Circuits (15 points)

1. (5pt) The following circuit uses 1N750 zener diodes. Which plot correctly shows the input and output voltages.

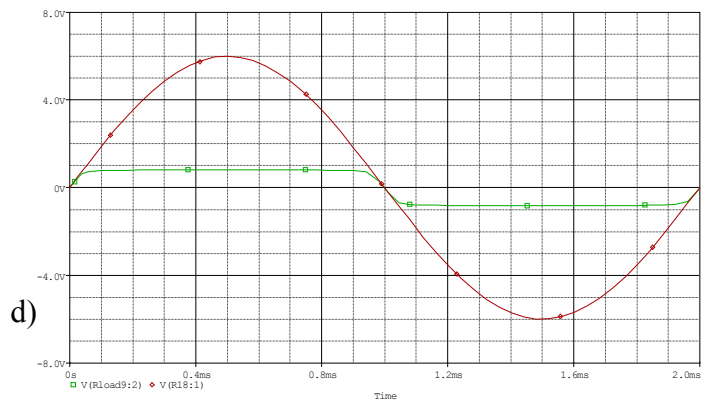
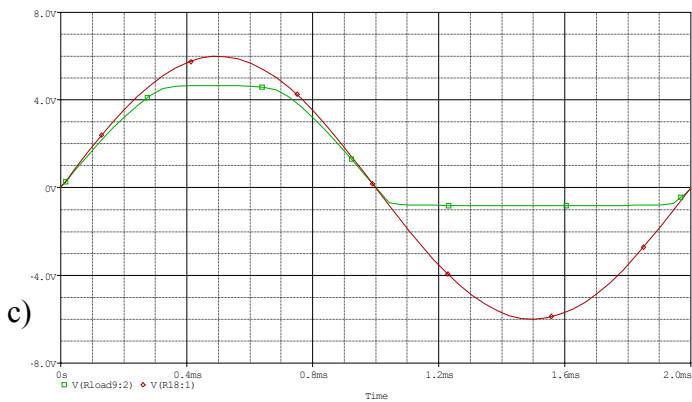
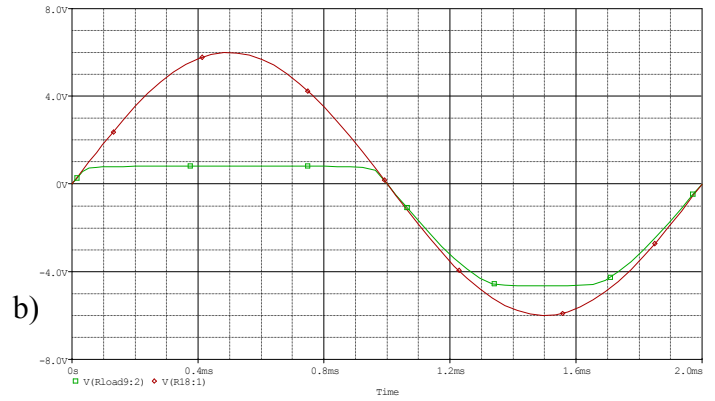
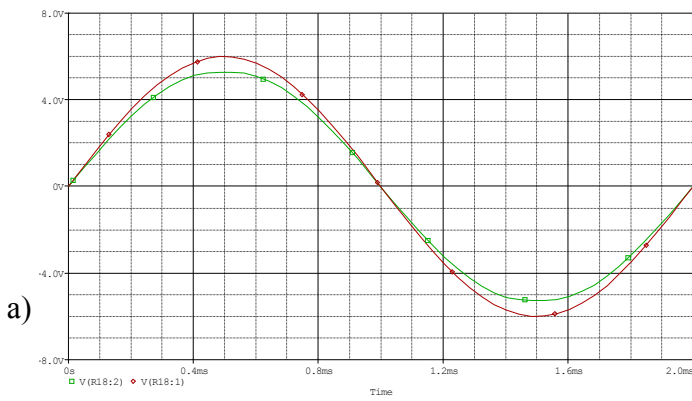
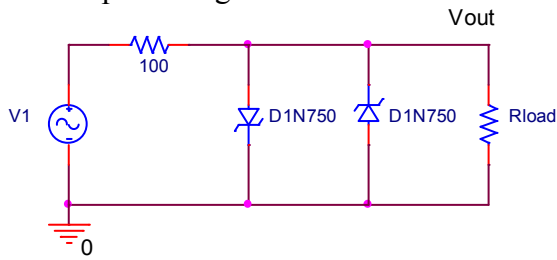

2. (5pt) For the modified circuit, sketch the output  $V_{out}$  on the axes below with V1.

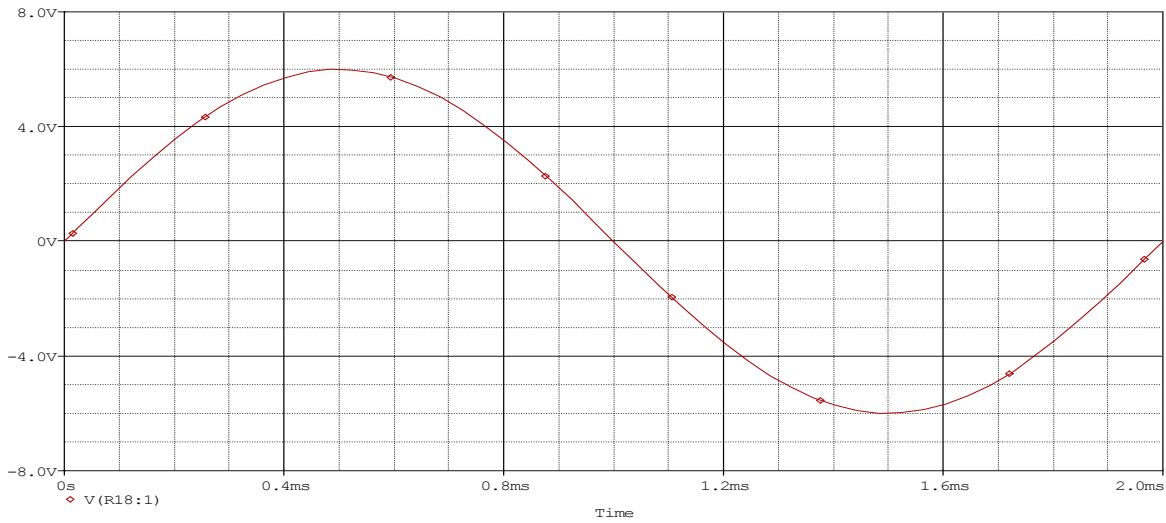
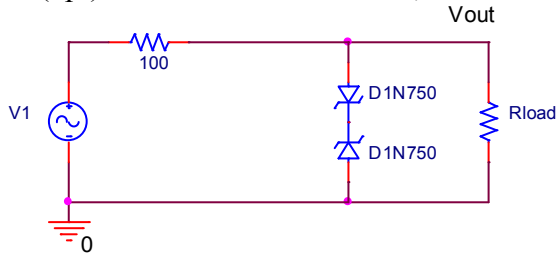

3. (5pt) For a (new) zener diode circuit whose input and output vs. time are given for a 12V sine wave, plot the input-output curve below for V1 from -12V to +12V. Scale the  $V_{out}$  axis.

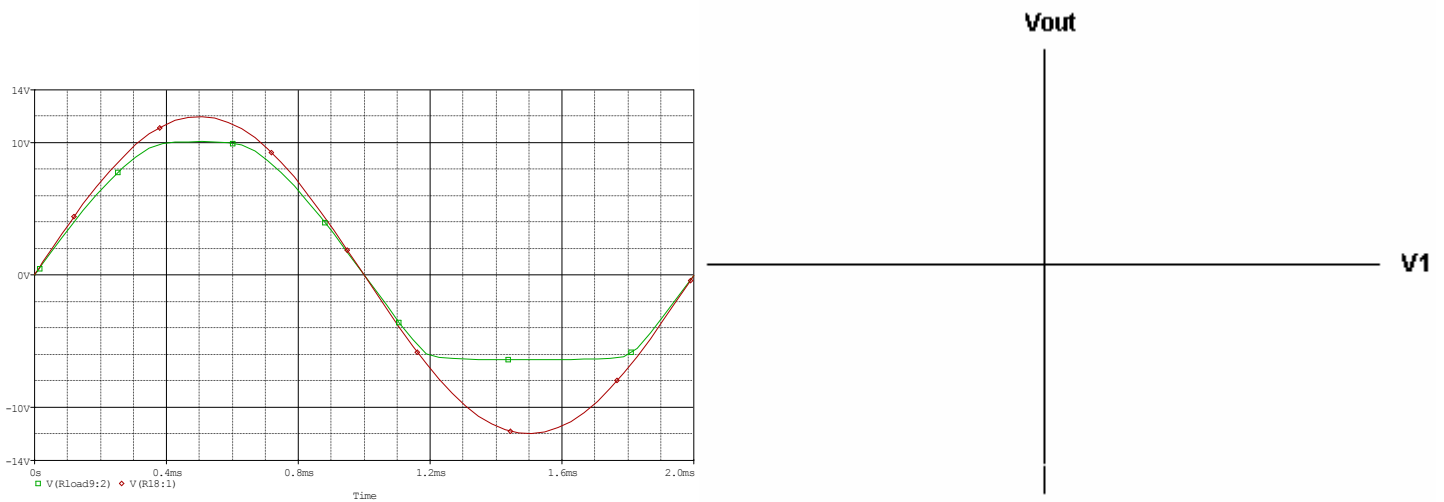

**Question III – LEDs and Phototransistor Circuits (14 points)**

In the circuit below LEDs D1 and D2 are both used to activate phototransistor Q1. Assume ideal logic voltage levels of 0 or 5V, the LEDs turn on for the correct voltage polarity, and that when activated, the phototransistor may be treated as an ideal switch that is closed with zero resistance between the emitter and collector. (HINT: when C = 0, it can be set to 0V or ground. This is true for any logic wire.)

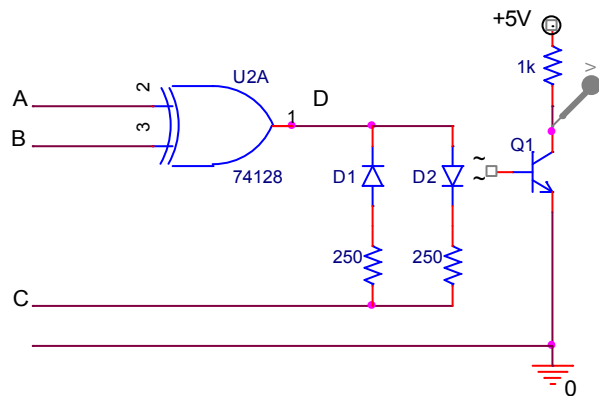

1. (8pt) Fill in the table and determine when the LEDs are on.

A	B	C	D	D1 (on or off)	D2 (on or off)
0	0	0			
0	1	0			
1	0	0			
1	1	0			
0	0	1			
0	1	1			
1	0	1			
1	1	1			

2. (2pt) In general, given the 2 parallel LEDs between D and C, is there a set of voltages that can be applied to C and D which will turn on both LEDs simultaneously?

3. (4pt) For which combination(s) of A B C will the voltage measured on the probe be high (close to 5V)?

Question IV - Diode Limiter Circuits (23 points)

You are given the following circuit:

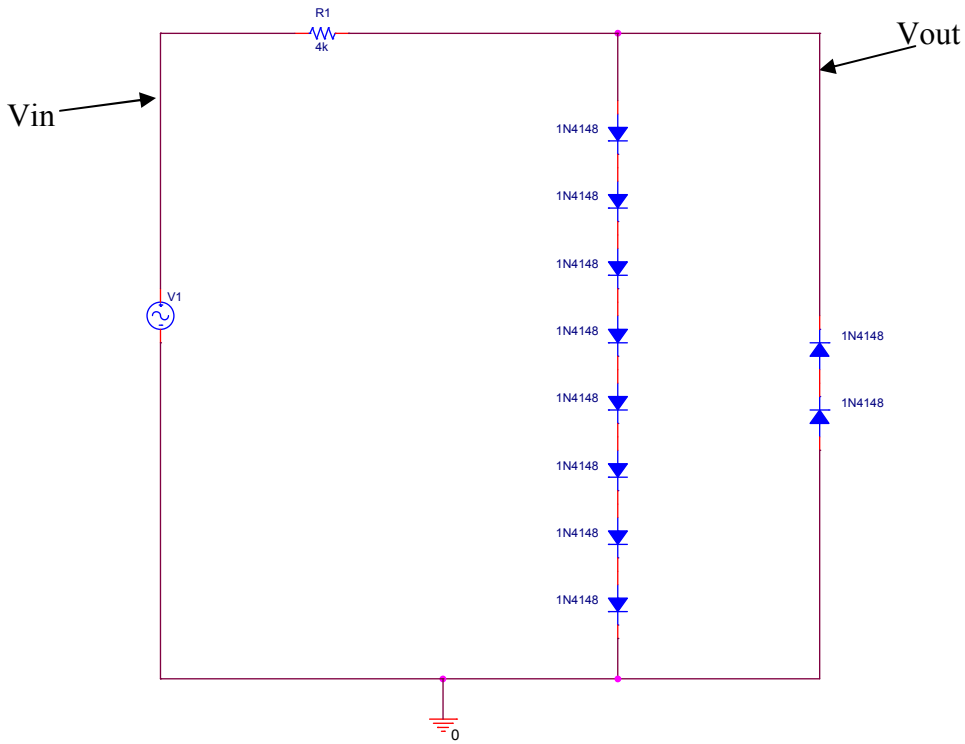

1. (4pt) What are the minimum and maximum voltages that can ever occur at Vout?

2. (5pt) Sketch Vin and Vout when V1 is VAMPL = 7V VOFF = 0V FREQ = 1kHz

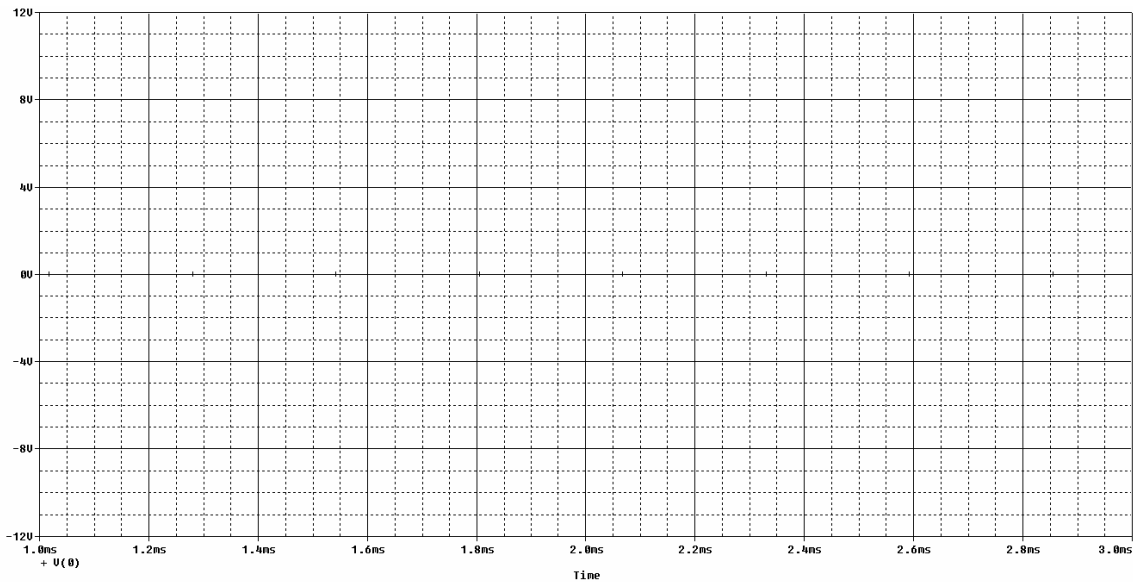

3. (5pt) Sketch  $V_{in}$  and  $V_{out}$  when  $V_1$  is  $V_{AMPL} = 7V$   $V_{OFF} = 3V$   $FREQ = 2kHz$

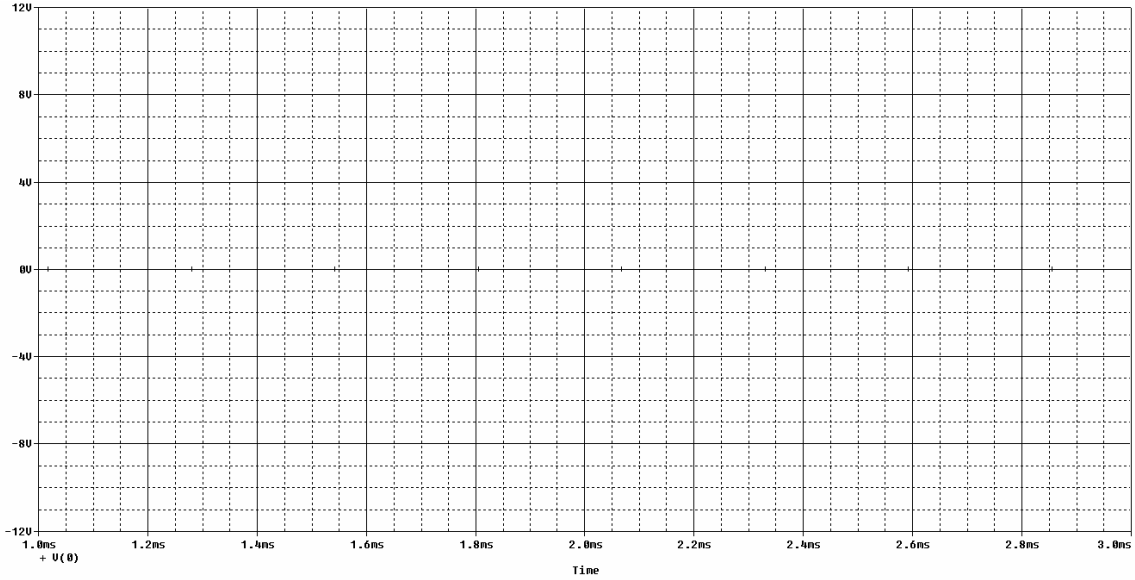

4. (5pt) Sketch  $V_{in}$  and  $V_{out}$  when  $V_1$  is  $V_{AMPL} = 7V$   $V_{OFF} = -3V$   $FREQ = 500Hz$

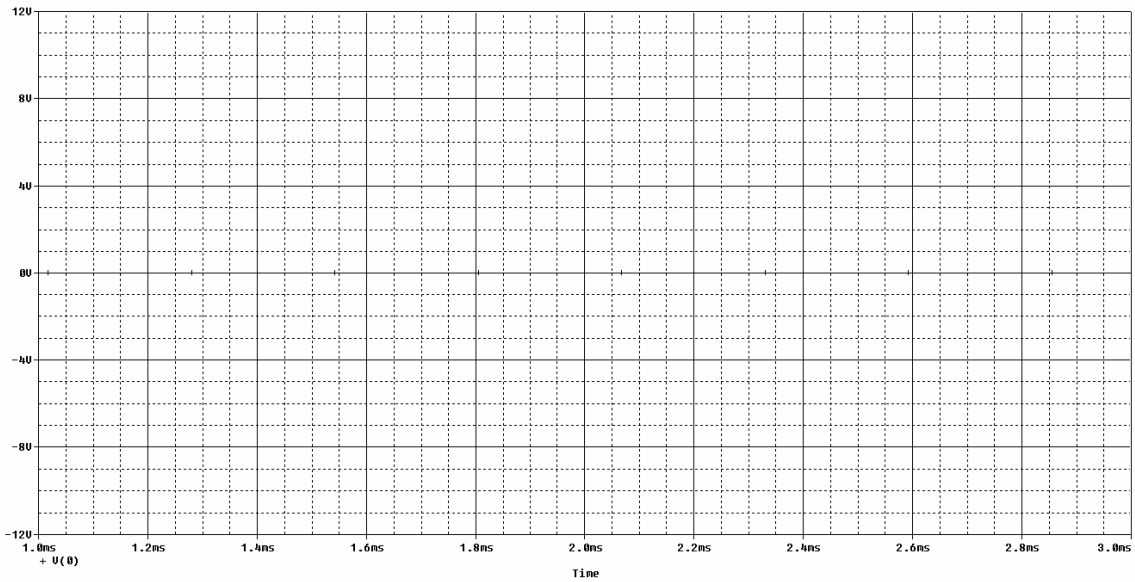

5. (2pt) What is the maximum current that will flow through resistor,  $R_1 = 4k\Omega$ , when  $V_1$  is  $V_{AMPL} = 7V$   $V_{OFF} = -3V$   $FREQ = 500Hz$ ? (This is the input you drew in sketch 3.)



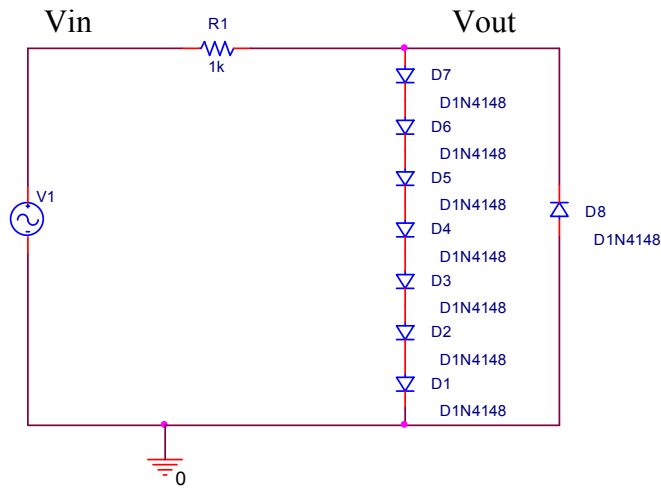

6. (2pt) Indicate the circuit below that would produce output most like the circuit above.

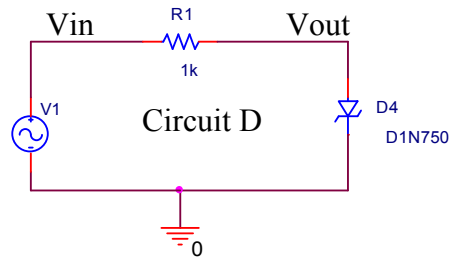
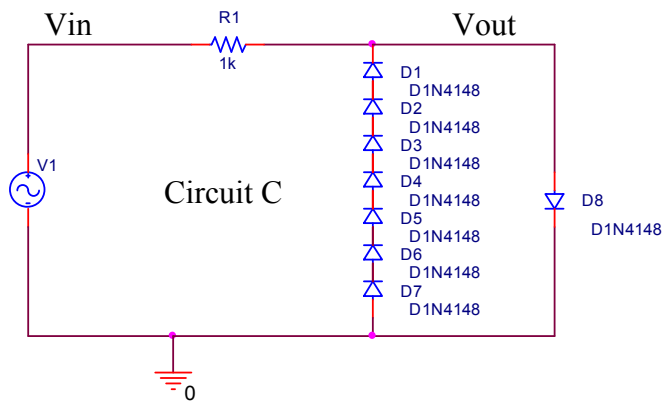
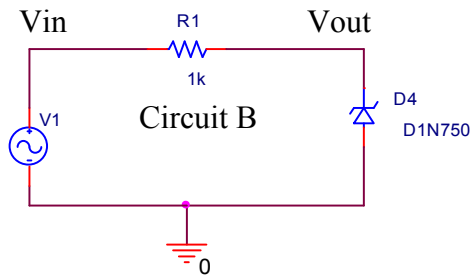
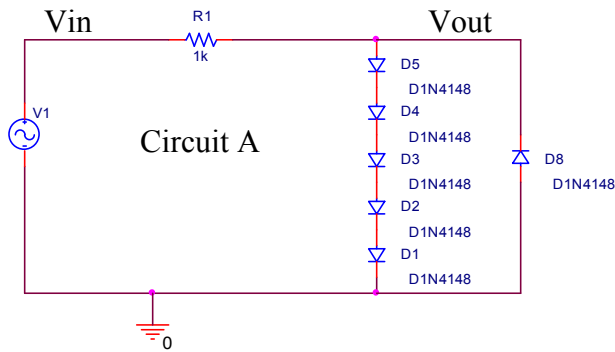

## Question V – Signal Modulation and Filtering (25 points)

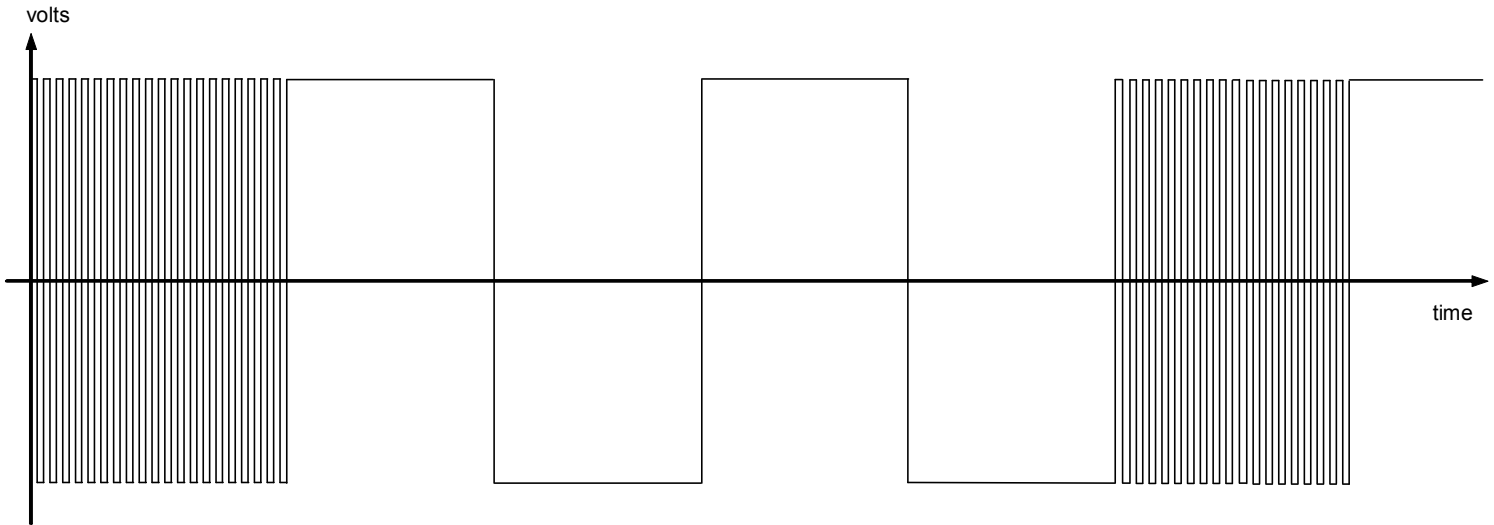

1. (3pt) For the above time signal, what type of modulation is most likely being used?  
 a) Amplitude Modulation   b) Frequency Modulation   c) Pulse Position Modulation  
 d) Pulse Width Modulation.

For questions 2 & 3 it is acceptable to substitute a sine wave with the same frequency for the square waves above.

2. (3pt) It is desired to build a receiver that inputs the signal in 1. and outputs a signal with a relatively large amplitude (logic 1) for the wide pulses and a relatively small amplitude (logic 0) for the narrow pulses by filtering. The most appropriate filter would be:  
 a) Low Pass   b) High Pass   c) Band Pass   d) Band Reject   e) All Pass
3. (5pt) Assuming the narrow and wide pulses have a PERIOD of 0.2ms and 10ms respectively (plot is not to scale), what would be an appropriate filter corner frequency (in radians) that would distinguish between the 2 parts of the signal by producing different output magnitudes for each?

4. (5pt) It is decided to use the circuit below as part of the detection system. Find an appropriate value for C1 based on your frequency in 3. (Op-amp power supplies are correctly wired.)

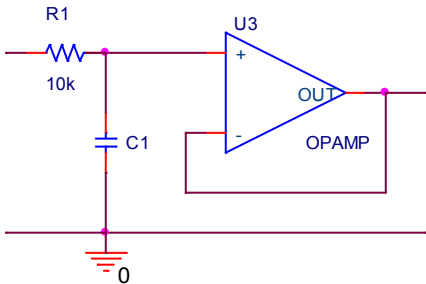

5. (5pt) Find the simplified transfer function  $H(j\omega)$  for the circuit in 4. in terms of R1 and C1.

6. (3pt) TRUE or FALSE: With appropriate selection of values for Rin, Cin, and Rf the circuit below will have the same transfer function and characteristics as the circuit in 4, except for a sign inversion (multiplied by -1).

