

Project 1
 RF Notch Filter
Trap for Unwanted Frequencies

(Open Shop: September 19th; Due: October 3rd)

For this project, students can work in groups of two to four. Hand in one report for each group.

Grading

1. Design (10 pts)	_____
2. Analysis of Design (10 pts)	_____
3. Frequency Response for Design (20 pts)	_____
4. Performance of Design (10 pts)	_____
Task Breakdown (0 pts, but required)	_____
 Total	 _____

Group Members:

1. _____
2. _____
3. _____
4. _____

Television

Some background information and general TV history resources:

1. List of significant historical events in TV history:
http://en.wikipedia.org/wiki/List_of_%27years_in_television%27
2. Alan B. Dumont, RPI grad who built the first practical TV:
http://en.wikipedia.org/wiki/Allen_B._DuMont (check out the link to Rensselaer on this page for some very interesting info)
3. Television History, the first 75 years: <http://www.tvhistory.tv/>
4. The history of TV: <http://inventors.about.com/library/inventors/bltelevision.htm>
5. Radio and television history sites: <http://www.rtvf.unt.edu/links/histsites.htm>
6. Media History: <http://www.mediahistory.umn.edu/teevee.html>

Television channel frequencies:

1. <http://www.arrl.org/tis/info/catv-ch.html>
2. <http://www.atxnetworks.com/qrf/catvfrq1.htm>
3. <http://www.tvtower.com/Commercial%20Television%20Frequencies.html>
4. <http://www.w4zt.com/freqs/catv.html>
5. <http://www.turnkey.net/CATV%20frequencies.htm>
6. <http://www.chem.hawaii.edu/uham/catvfreq.html>



1939 Du Mont Model 183 - 14" Screen

1953 Sharp - TV3-14T
First Japanese TV



© 2003 TVhistory.TV

1952 Zenith (USA)
21" Model K2230R



TVhistory.TV
Photo is from Sams Photofact © 1957, dated Dec; 1957
Reprinted with permission of Sams Technical Publishing

1952 RCA -- 17" Model 7T122 (USA)



© 2004 TVhistory.TV



1950 Du Mont (USA)
19" RA-109-A2 "Hanover"

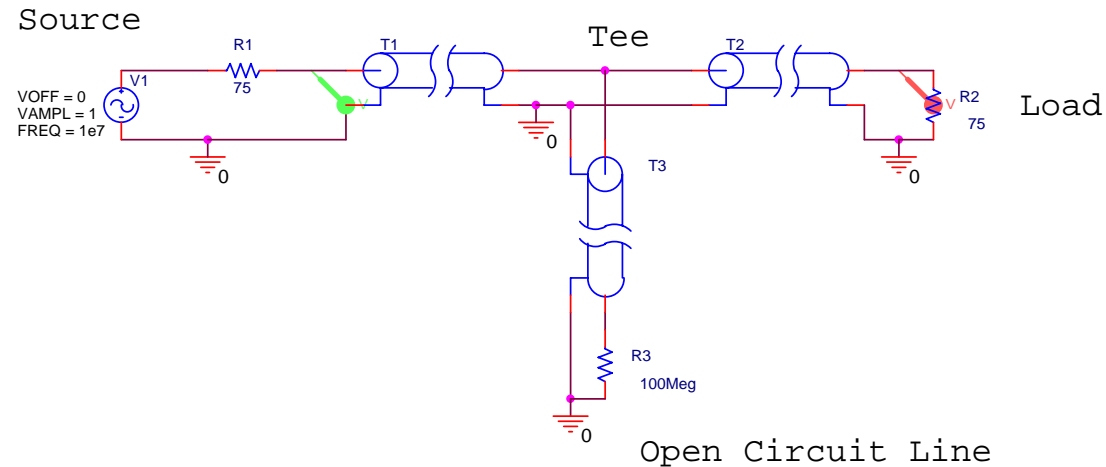

© 2003 TVhistory.TV

Filter**Introduction**

The purpose of this project is to build a simple device that blocks the signal from a particular frequency while passing a signal at a second frequency. No active or lumped circuit elements will be used for this purpose. Rather, this will be accomplished by adding a stub-type tuner to the cable that brings the signal to the load. A picture of a standard triple-stub tuner (it has three shorted stubs with the ability to adjust the length of the stub) is shown in the following picture.



The basic principle of this signal blocker is relatively simple. The input cable (T1 in the figure above) is interrupted with a Tee coupler to which is connected a short piece of cable (T3 above) with no load (open circuited line). The input impedance of this extra piece of cable adds in parallel to the input impedance of the cable that runs from the Tee to the load (T2 above). Assuming that the cable is properly matched to the load, the input impedance of this cable will be equal to the characteristic impedance of the cable. In this case, the impedance of the cable and the load is 75 ohms (as in a TV system). Since the input impedance Z_{in} is a function of the electrical length of the cable (through the terms like $\tan\beta d$ where d is the length), the Z_{in} of the short-circuited cable will change with frequency. If the length of this cable is properly selected, the signal from one frequency will be reflected from the Tee while the signals from other frequencies will not be reflected. A crude explanation of how this can work can be made by looking just at two frequencies where Z_{in} is either very small or very large.

For example, assume that the extra piece of cable has a length = d . Also, assume that it is insulated with polyethylene $\epsilon_r = 2.26$. Then the velocity of propagation on the line is $v = 2 \times 10^8$ m/s. In the simulation of this line, one can either reduce the expression for Z_{in} for a short circuit or just use a very small value for Z_L . To be as general as possible, we should choose the latter approach, because there will always be some loss in a real

transmission line. Then $Z_{in} = Z_o \frac{Z_L + jZ_o \tan \beta d}{Z_o + jZ_L \tan \beta d} \approx jZ_o \tan \beta d$, where we have assumed

that the transmission line is ideal and therefore lossless. When this is very large ($\tan \beta d \rightarrow \infty$), adding it in parallel to the cable will have no effect. When this is very small ($\tan \beta d \rightarrow 0$), adding it in parallel to the cable will look like a short circuit, which is as large an impedance mismatch as can be obtained. The input signal will see a short-circuit load at the frequency where $\tan \beta d \rightarrow 0$ and the signal at that frequency will be reflected from the Tee and not make it to the load.

Why would we want to do this? First, assume that the system of interest is the cable TV system in your residence. Let us assume that you would like to block one of the channels coming in for some reason. You can select the parameters of the open circuited stub (as such short cables are called) to short out the signal at the frequency of the unwanted channel. If you do this correctly, you will leave the other channels unaffected.

Information on the frequencies of cable TV channels can be found on our Supplementary Materials Webpage. Second, assume that you are doing some kind of an RF (Radio Frequency) experiment involving a low power signal at 144MHz. For example, moon bounce experiments are done at this frequency. Unfortunately, the signal is very small coming back from the moon and there is a lot of power in the FM broadcast band near 100MHz. This FM station power, if detected by your receiver can saturate the front-end amplifier so it is not able to amplify the signal you sent to the moon. To avoid this problem, you can filter out or block the FM signals before they get to your amplifier so it is able to respond to the signal at 144MHz. There is a short description of this situation at <http://www.vhfdx.net/qrmfm.html>. (QRM is signal interference.) There is also an extensive description of eliminating AM band frequencies at <http://www.dxing.com/tnotes/tnote06.pdf>. Third, you may be operating some kind of wireless system where there is a lot of noise generated (by a motor or some other system) at several harmonics of 6kHz. Again, to block out the noise, you can use some kind of filter.

The simple, single open stub configuration shown above is probably the simplest way to build such a filter. You could also do it with discrete components, as shown in the following figure. Several schemes for discrete component filters can be found in the [dxing.com](http://www.dxing.com) link in the previous paragraph.

Fields and Waves I

ECSE-2100

Fall 2007

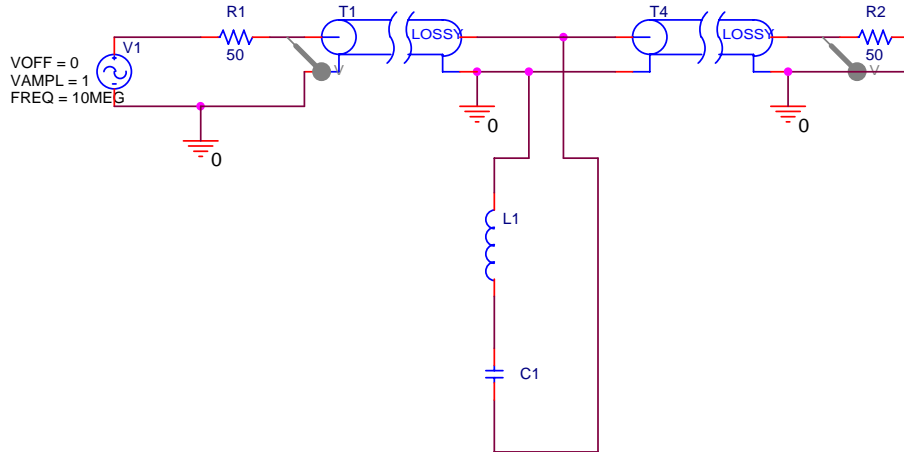

At the resonant frequency of the LC combination, there will be a short across the line and the input signal will not reach the load. Both of these can work, but there are other options that generally work better, including the more elaborate discrete component filters in the dxing.com link. Several options follow.

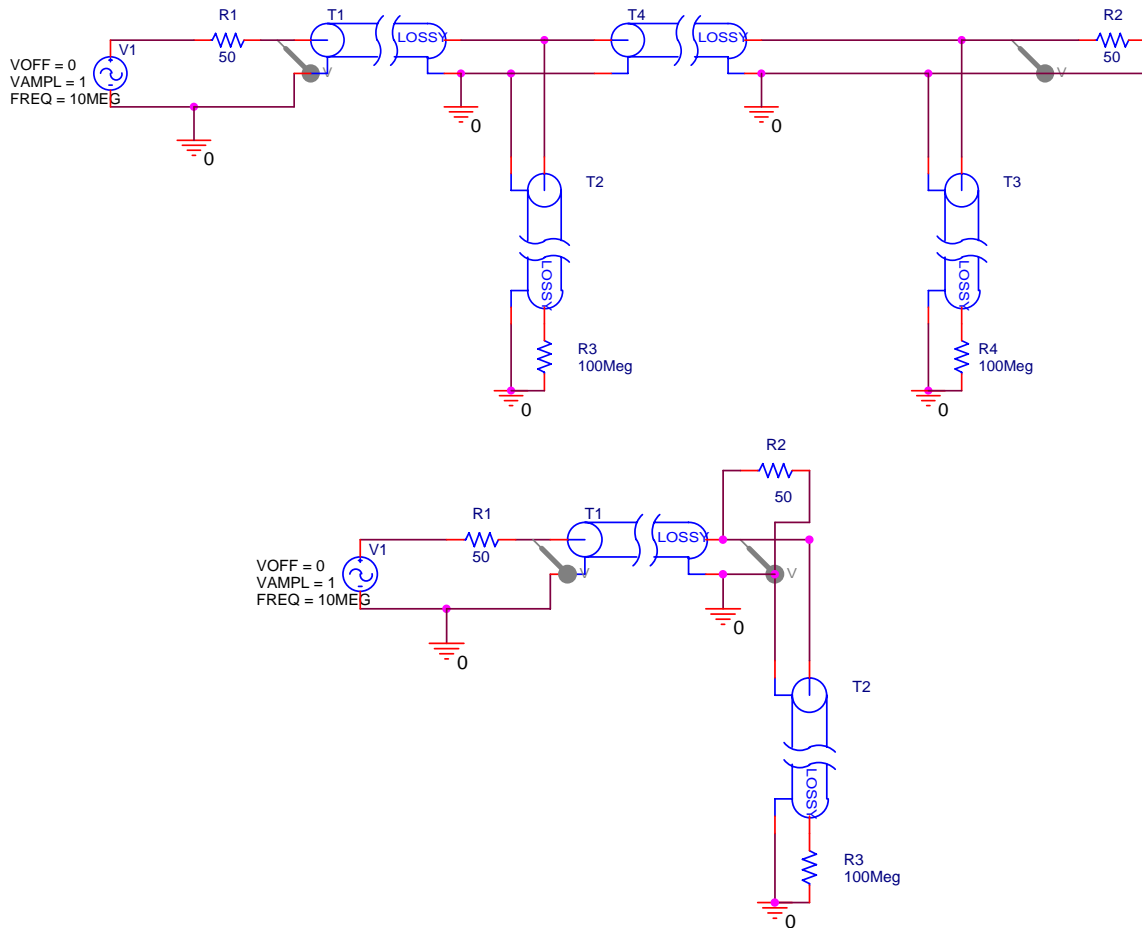

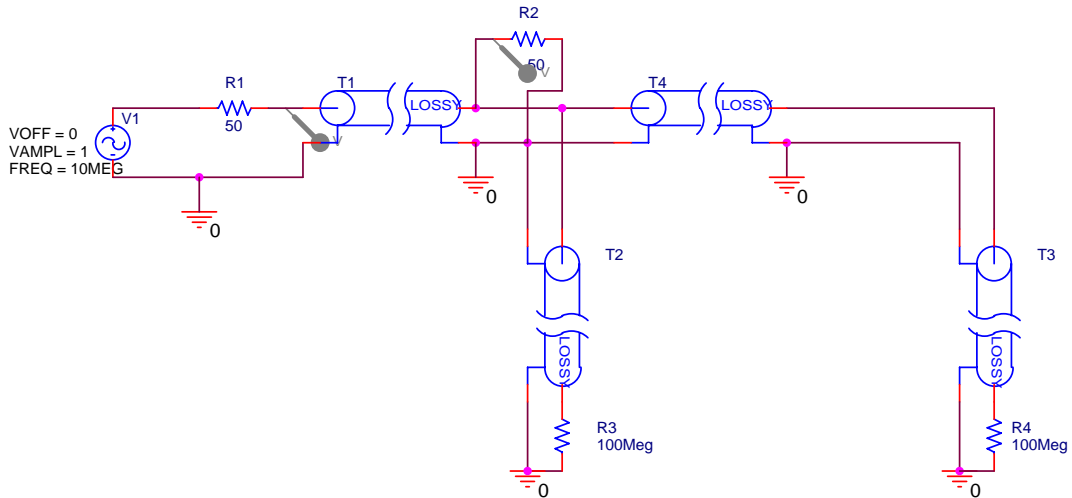

The first option is a double stub circuit. The second and third move the single and double stubs directly across the load instead of between the load and the source. These options can also be shown generically.

Double Open Stub Tuning

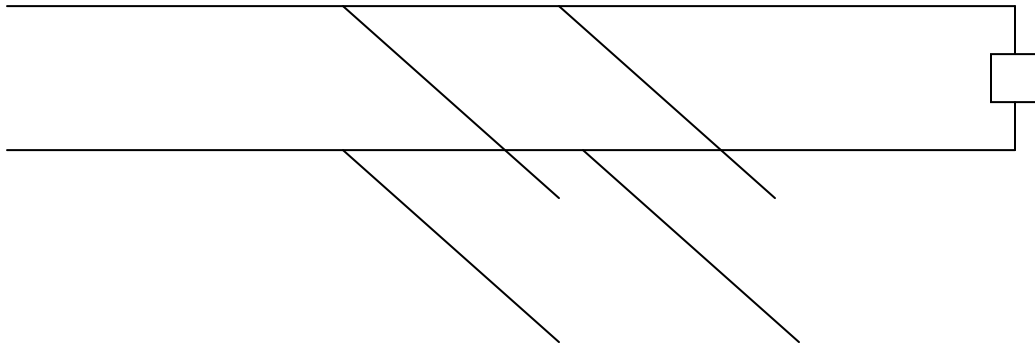

Single Open Stub Tuning

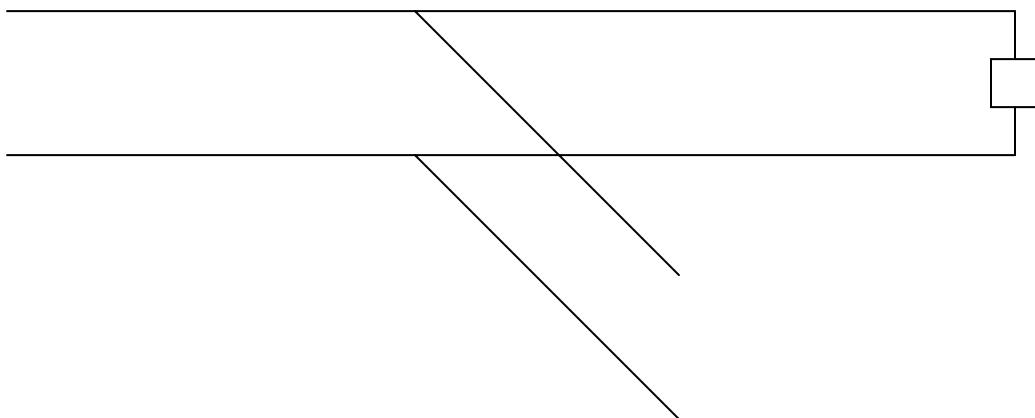

Single Open Stub Filter at Load



Double Open Stub Filter at Load



The first set of pictures was generated using the student version of PSpice. Using this program is one of the options you will have for this project. Note that there are two kinds of transmission lines shown. One is ideal and the other is lossy. Both are useful. Also, the source frequency in these figures is 10MHz. We will use this frequency to address an experiment you can do in the studio classroom. We will use something around 100MHz for blocking a cable TV signal.

Look to the Past: Those of you who know how this project was specified in the past will note that we have previously used either a short-circuited or an open-circuited line. The open-circuited line is easier to implement, since one only needs to cut a wire and leave it unconnected. However, even a small amount of open wire at the end of the line will act like an antenna. This is not necessarily a serious problem, so this time we will use an open stub. Those of you who have heard nothing about this project should look over the Fall '99 project write up, which can be found at the bottom of the course Project page.

There is also a set of comments on this project which includes a lot of the important analysis steps for the channel blocker. This latter document should be read thoroughly.

Analysis Option 1: In the project from Fall '99, the channel blocker circuit was modeled using Matlab. You can use the program listing provided in the comments as a guide. The comments also include sample plots. Also, see the Matlab analysis document that you can link to from the project page.

Analysis Option 2: The traditional way to analyze stub filters is to use a Smith Chart. This is discussed in the text book and at the following sites on the web.

Smith Chart References:

http://weewave.mer.utexas.edu/DPN_files/courses/363M/tuner_exmpl/dbl_tnr.html

<http://www.ee.surrey.ac.uk/Personal/D.Jefferies/stubs.html>

<http://people.deas.harvard.edu/~jones/es151/pages/gallery/gallery.html>

http://www.eecs.umich.edu/emag/labmanual/EECS230_LE5.pdf

Analysis Option 3: Since transmission lines can be modeled using PSpice, you can do your analysis by downloading the student version of this excellent program. Please also see the PSpice analysis document linked to on the projects page.

Overall Goals:

In this project, you are to consider the various configurations for the blocker or filter and decide which works the best. You can use any of the three analysis options. The output from your analysis should show how well the filter will work. This requires that the loss in the lines be included (which it is not in the Fall '99 Matlab file).

You must design two systems. One should block some cable TV channel and leave most other channels unaffected. The other should block 10MHz while allowing 14.4MHz to pass more-or-less unaffected.

Once the analysis has been done, you must either build a channel blocker for a TV channel (two F-type Tee connectors will be provided, but you will have to obtain your own cable) or do the experiment in the studio showing that the 10MHz signal is blocked while the 14.4MHz signal is not. If you choose to build the TV channel blocker, you should test it yourself and record the results (e.g. channels blocked and channels unaffected). Then, you must demonstrate its efficacy to a TA using the cable feed in the studio. If you do the lower frequency experiment in the studio, you must record the input and output voltages at 8MHz, 9MHz ... 15MHz (1MHz increments).

Specific Tasks:

1. Specify two filter schemes. Draw each configuration. Be sufficiently complete so that you can analyze your design. (10 pts)
2. Using one of the three analysis options, analyze the filter schemes (show your work). *The purpose of this section is to show that you understand how to do the analysis. Thus, you should do some simple calculations and explain your approach, step-by-step. The results (plots) for your analysis are asked for in the next section.*
 - a. Blocking 10MHz while passing 14.4MHz (as in the studio)
 - i. **Design** (5 pts)
 - b. Blocking a cable TV station (your choice) while leaving as many other channels as possible unaffected.
 - i. **Design** (5 pts)
3. For all three types of analysis, do it first for lossless lines. Then it must be repeated for lossy lines. *Note that you are to do only one of these options. You must also clearly annotate your plots so it is completely clear what information they contain.*
 - a. *For all three options, you are to determine the phasor voltage everywhere on the open-circuit stubs and on the line going to the 75 Ohm load (e.g. the TV). Make any reasonable assumptions.*
 - b. For the Matlab analysis, you should produce a plot like the transmission coefficient plot on pages 5 and 8 of the project 2 comments (Fall '99) found on the course Project Webpage. (20 pts)
 - c. For PSpice, you should produce a plot of the voltage vs. frequency at the load. In both cases, the frequency range should cover 1MHz to 20MHz for the studio experiment and all cable TV frequencies for the TV channel blocker. (20 pts)
 - d. For the Smith Chart approach, you will have to include all of your Smith Charts. The Smith Chart analysis must be done for at least 5 representative frequencies, including the specific frequencies of interest. *Note – this option probably requires the biggest time investment to learn. You should probably not try it unless you have had a little experience with Smith Charts before or unless you find graphical tools to be particularly useful.* (20 pts).
 - e. *For all three options, determine the phasor voltage on all cables for extra credit. (5 pts).*
4. Either build and test the TV channel blocker or do the lower frequency experiment in the studio. If you choose to do the channel blocker, it must be

turned in with your report and tested in class jointly with one of the course instructors *Note—the extra cables we have just acquired in the studio classroom for this project are made from some old Ethernet cable that has a different propagation velocity. You will need to develop and test your design for a velocity of 2.3×10^8 m/s instead of the usual 2×10^8 m/s.*

a. **Preferred Design** (10 pts)

Task Breakdown: You must formally divide the work up in this project and assign each task to a member of your group. For example, one person can work on the report, one can build or test designs, one can do the analysis of one design and one analyze the other and, most importantly, one can be responsible for coordinating all the tasks and making sure that everyone is on schedule. In your project report, you must clearly describe how you divided up the work and who did what. *There are no points for this, but no report will be accepted without it.*

It is likely that this project description will be updated. Please check class announcements and your email on a regular basis.