

N5532A Sensor Module User's and Service Guide

for the Agilent N5531S and N5530S Measuring Receiver Systems



**Manufacturing Part Number: N5532-90006
Supersedes Part Number N5532-90006, June 2008**

Printed in USA

February 2009

© Copyright 2004-2009 Agilent Technologies

Notice

The information contained in this document is subject to change without notice.

Agilent Technologies makes no warranty of any kind with regard to this material, including but not limited to, the implied warranties of merchantability and fitness for a particular purpose. Agilent Technologies shall not be liable for errors contained herein or for incidental or consequential damages in connection with the furnishing, performance, or use of this material.

The following safety symbols are used throughout this manual. Familiarize yourself with the symbols and their meaning before operating this equipment.

WARNING

***Warning* denotes a hazard. It calls attention to a procedure which, if not correctly performed or adhered to, could result in injury or loss of life. Do not proceed beyond a warning note until the indicated conditions are fully understood and met.**

CAUTION

Caution denotes a hazard. It calls attention to a procedure that, if not correctly performed or adhered to, could result in damage to or destruction of the instrument. Do not proceed beyond a caution sign until the indicated conditions are fully understood and met.

NOTE

Note calls out special information for the user's attention. It provides operational information or additional instructions of which the user should be aware.

Warranty

This Agilent Technologies instrument product is warranted against defects in material and workmanship for a period of one year from date of shipment. During the warranty period, Agilent Technologies will, at its option, either repair or replace products that prove to be defective.

For warranty service or repair, this product must be returned to a service facility designated by Agilent Technologies. Buyer shall prepay shipping charges to Agilent Technologies and Agilent Technologies shall pay shipping charges to return the product to Buyer. However, Buyer shall pay all shipping charges, duties, and taxes for products returned to Agilent Technologies from another country.

1. General Information	
Description	6
N5532A Block Diagram	7
Instruments Covered by Manual	8
2. Installation	
Initial Inspection	10
Operating Precautions	10
Installing the Calibration Factors	12
Installing the Cal Factors in the N5530S	12
Installing the Cal Factors in the N5531S	13
3. Specifications	
N5532A Sensor Module Specifications	16
N5532A Sensor Module Supplemental Information	18
4. Maintenance and Repair	
Maintenance	22
Repair	23
Assembly Replacement Procedures	23
Replaceable Parts	39
Calibration	43
Cal Factor Data File Format	46
Contacting Agilent Technologies	48

Contents

1 General Information

This user guide contains information about installation, operation, product specifications, calibration data, maintenance and repair, and storage conditions of the N5532A Sensor Module.

Description

The N5532A is intended to be used with the N5531S or the early N5530S Measuring Receiver System. It is essentially a power sensor with a power splitter at the input. See [Figure 1-1 on page 7](#). In use, the sensor module's two output cables are connected to a power meter (E4418/19, E4416/17, or N1911/12 Series) and the Performance Spectrum Analyzer (PSA) RF Input. When using an N1911 or N1912 Series power meter, it is necessary to use an adapter (N5532A Option 019) to connect the output cable of the sensor module to the power meter. The sensor module is calibrated such that the power meter indicates the power supplied by the source under test.

The N5532A Sensor Module is offered in four frequency configurations:

- Option 504 covers 100 kHz to 4.2 GHz
- Option 518 covers 10 MHz to 18 GHz
- Option 526 covers 30 MHz to 26.5 GHz
- Option 550 covers 30 MHz to 50 GHz
(with adaptor 11903D 2.4mm (f) to Type N (m))

The sensor module accurately measures power levels from -20 dBm to +30 dBm (10 μ W to 1 W). Calibration Factor (Cal Factor) information is unique to each sensor module and is supplied on a floppy disc included with each N5532A. Please refer to [“Installing the Calibration Factors” on page 2-12](#) for more information on using the Cal Factor Data.

NOTE The N5532A Sensor Module is compatible ONLY with the newer E4418/19, E4416/17, or N1911/12 Series power meters. They are NOT compatible with the earlier 430 Series or 70100 power meters. If used with an N1911/12 Series power meter, an adapter (N5532A Option 019) is required to connect the dc cable to the power meter.

N5532A Block Diagram

Figure 1-1 N5532A Sensor Module

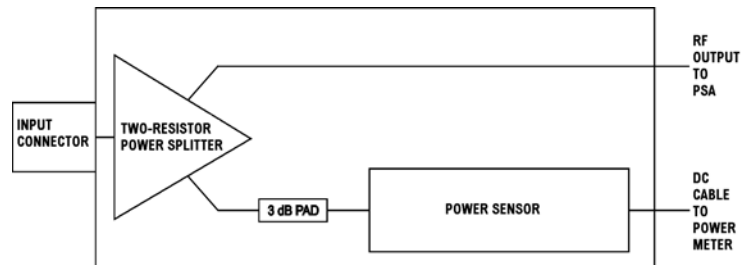

Instruments Covered by Manual

These instruments have a two-part serial number: the prefix (two letters and the first four numbers), and the suffix (the last four numbers). The two letters identify the country in which the unit was manufactured. The four numbers of the prefix are a code identifying the date of the last major design change incorporated in your Agilent Technologies product. The four-digit suffix is a sequential number and coupled with the prefix, provides a unique identification for each unit produced. The contents of this manual apply directly to all serial numbers unless otherwise indicated.

2 Installation

Initial Inspection

Inspect the shipping container for damage. If the shipping container or packaging material is damaged, it should be kept until the contents of the shipment have been checked mechanically and electrically. If there is mechanical damage notify the nearest Agilent Technologies office as shown in [Table 4-3 on page 48](#). Keep the damaged shipping materials (if any) for inspection by the carrier and an Agilent Technologies representative.

Operating Precautions

NOTE

For optimal results, the sensor module must be placed on a supportive surface with the serial number label facing up. This orientation provides repeatable measurements by eliminating strain on the input connector.

The input connector should be torqued to 12 in-lb (135 Ncm) for the type-N connector, 8 in-lb (90 Ncm) for the APC 3.5 mm connector, or 8 in-lb (90 Ncm) for the 2.4 mm connector to ensure a repeatable connection in order to meet the published specifications. Exceeding these torque settings may damage the connector.

Connect the sensor module by turning only the hex nut portion of the connector. Damage can occur if torque is applied to the sensor module body.

The connector plastic insulator bead deteriorates when contacted by acetone, trichloroethylene, carbon tetrachloride, benzene, etc.

WARNING

BEFORE CONNECTING THE SENSOR MODULE TO OTHER INSTRUMENTS, ensure that all instruments are connected to the protective (earth) ground. Any interruption of the protective earth grounding will cause a potential shock hazard that could result in personal injury and cause damage to the sensor module.

CAUTION

To prevent physical damage to the sensor module or device-under-test (DUT), pay careful attention to the mechanical setup. The mechanical design of the sensor module minimizes SWR. However, the weight and length of the module, combined with the stiffness of the interconnect cables, enables the exertion of considerable leverage at the module's input connector. To prevent physical damage to the sensor module, the DUT, and the mating connectors, and to assure best electrical performance, observe the following precautions:

1. Do not permit the interconnect cables of the sensor module to extend out where anyone passing by could accidentally push and exert leverage on the cables. This consideration is especially important when the DUT is a light-weight instrument that sits freely on a table.
 2. When possible, lay the sensor module on a supportive surface with the serial number label facing up. This consideration is especially important when rigid RF adapters are used to directly interconnect the sensor module to the DUT. RF adapters lengthen the leverage arm of the sensor module and are often fragile. When level-accuracy requirements permit, use flexible cables to interconnect the sensor module to the DUT.
 3. Do not bend or coil the interconnect cables (more than necessary) to a diameter circumscribing less than 150 mm (6 in.). This precaution often applies when the instruments are rack-mounted and interconnected to rear-panel connectors. Repeated flexing of coiled, interconnect cables can degrade SWR and increase RFI of the RF output cable.
 4. Do not attempt to tighten the sensor module input connector by twisting the body of the sensor module.
-

Installing the Calibration Factors

Cal factors can be entered and stored in an internal table (Automatic Cal Factors) in the PSA's non-volatile memory. The table is automatically accessed during RF power measurements (after the measuring receiver has tuned to the frequency) to correct for the non-linear response of the power sensor. If no entry in the table directly corresponds to the frequency being measured, the measuring receiver derives a cal factor through linear interpolation using the nearest calibration points in the table.

Installing the Cal Factors in the N5530S

There are two methods of installing the sensor module calibration factors (cal factors) in the N5530S Measuring Receiver System.

The first method loads and saves the cal factors using the PC. The second method uses the PSA to load the data.

Figure 2-1 Utilities Menu

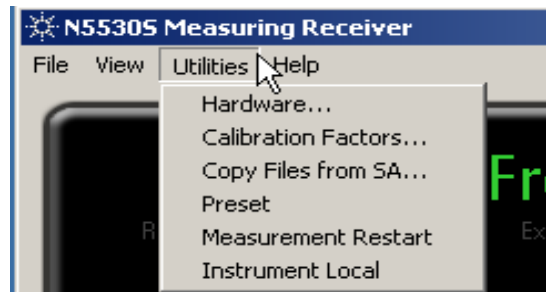

Both methods are accessed through the Utilities drop-down menu (See [Figure 2-1](#), “Utilities Menu.”.)

Using the PC to Load and Save the Cal Factors

1. Insert the N5532A Sensor Module Data Disk in the PC A:\ drive.

NOTE If your PC does not have a floppy disc drive, use the PSA to save your cal data to your PC. Then use this procedure to load the sensor cal factors into the system.

2. Select **Calibration Factors** to bring up the **Calibration View Edit** dialog box.
3. Press **Load Cal File** in the **Calibration View Edit** dialog box. The **Open Calibration File** dialog box appears.
4. Navigate to the PC A:\ drive if necessary and select the CFData.XML file.

NOTE If you obtained the cal data from the PSA, go to the directory you specified in [Step 2](#) of the next section to load the data.

5. Press **Open**.
6. Press **OK** to apply the Cal Factors to the system.

Using the PSA to Save the Cal Factors to the PC

1. Insert the N5532A Sensor Module Data Disk into the PSA A:\ drive.
2. Select **Copy Files from SA** under the **Utilities** menu option of the N5531S or N5530S User Interface. Browse to the location you wish to place the SA floppy disc files.
3. Click **OK** to copy the calibration factor files to the specified location. Three files appear: **CALTABLE.XSL** (enables viewing with web browser), **CFDATA.XML** (actual Cal Factor Data), and **CFCERT.DOC** (Cal Factor Certification)¹.
4. To load this data into the system, follow steps 2 through 6 in the section entitled, [“Using the PC to Load and Save the Cal Factors” on page 2-12.](#)

Installing the Cal Factors in the N5531S

1. Insert the floppy disk in to PSA floppy disk drive. Make sure the disk is for the sensor module you are using.
2. Press **MODE, Measuring Receiver, File, Load, Type**, and select **Calibration Factor** as the file type. Press **Dir Up, Up Arrow, Dir Select** to ensure the “A” drive is selected. Then press **Load Now** to load the cal factor file (**CFDATA.XML**) to the PSA spectrum analyzer.

1. . Provides traceability to National Institute of Standards and Technology or NIST

Installation
Installing the Calibration Factors

3 Specifications

The specifications listed in [Table 3-1, “Specifications,”](#) are the performance standards or limits against which the sensor module may be tested. These specifications are valid ONLY after proper calibration of the power meter.

N5532A Sensor Module Specifications

Table 3-1 Specifications

Description	Specification	Comments
Frequency Range Option 504 Option 518 Option 526 Option 550	100 kHz to 4.2 GHz 10 MHz to 18 GHz 30 MHz to 26.5 GHz 30 MHz to 50 GHz	
Power Range	+30 dBm (1 watt) to -20 dBm (10 μ W)	
Maximum Safe Power	+30 dBm	Average Total Power
Sensor Module Linearity <i>Opt. 504</i> +30 to +20 dBm < +20 dBm	$\pm 3\%$ negligible	
Sensor Module Linearity <i>Opt. 518</i> +30 to +20 dBm < +20 dBm	$\pm 3\%$ negligible	
Sensor Module Linearity <i>Opt. 526</i> +30 to +20 dBm < +20 dBm	$\pm 3\%$ negligible	
Sensor Module Linearity <i>Opt. 550</i> +30 to +20 dBm < +20 dBm	$\pm 3\%$ negligible	
Input SWR^a <i>Opt. 504</i> 100 kHz to 2 GHz 2 GHz to 4.2 GHz	< 1.10:1 < 1.28:1	

Table 3-1 Specifications

Description	Specification	Comments
Input SWR^a <i>Opt. 518</i> 10 MHz to 2 GHz 2 GHz to 18 GHz	 < 1.10:1 < 1.28:1	
Input SWR^a <i>Opt. 526</i> 30 MHz to 2 GHz 2 GHz to 18 GHz 18 GHz to 26.5 GHz	 < 1.10:1 < 1.28:1 < 1.40:1	
Input SWR^a <i>Opt. 550</i> 30 MHz to 2 GHz 2 GHz to 18 GHz 18 GHz to 26.5 GHz 26.5 GHz to 33 GHz 33 GHz to 40 GHz 40 GHz to 50 GHz	 < 1.10:1 < 1.28:1 < 1.40:1 < 1.55:1 < 1.70:1 < 1.75:1	

a. When connected to PSA with at least 30 dB attenuation

N5532A Sensor Module Supplemental Information

Table 3-2 Supplemental Information

Description	Supplemental Information	Comments
Input Impedance	50 ohms	
Input Connector Option 504 Option 518 Option 526 Option 550	Type-N (male) Type-N (male) APC 3.5 mm (male) 2.4 mm (male)	Recommended Torque 12 in-lbs (135 Ncm) 12 in-lbs (135 Ncm) 8 in-lbs (90 Ncm) 8 in-lbs (90 Ncm)
RF Output Insertion Loss <i>Opt. 504</i>	7 dB @ 3 Hz to 8 dB @ 4.2 GHz	Typical
RF Output Insertion Loss <i>Opt. 518</i>	7 dB @ 3 Hz to 11 dB @ 18 GHz	Typical
RF Output Insertion Loss <i>Opt. 526</i>	7 dB @ 3 Hz to 13 dB @ 26.5 GHz	Typical
RF Output Insertion Loss <i>Opt. 550</i>	7 dB @ 3 Hz to 16 dB @ 50 GHz	Typical
Military Specification	Type tested to an equivalent of MIL-PRF-28800F class 3 environmental specifications	
Altitude Operating Storage	< 4600 meters (15,000 feet) <7600 meters (25,000 feet)	
Temp. Range Operating Storage	0 to +55 °C – 40 to 70 °C	
Calibration Cycle	1 year	
Weight	0.72 kgm (1.5 lb)	
Shipping Weight	1.28 kgm (2.8 lb)	
Dimensions Height	51.2 mm (2 in)	

Table 3-2 Supplemental Information

Description	Supplemental Information	Comments
Width	62.4 mm (2.5 in)	
Length ^a	210 mm (8.3 in)	
Length ^b	1905 mm (75 in)	

- a. From input connector to end of plastic casing.
- b. From input connector to end of cable.

Table 3-3 Typical Cal Factor Uncertainty

Frequency Range	Typical Cal Factor Uncertainty			
	Opt 504	Opt 518	Opt 526	Opt 550
100 kHz to ≤ 30 MHz	± 2.0%			
30 MHz to ≤ 2 GHz	± 2.0%	± 2.0%	± 2.0%	± 2.0%
2 GHz to ≤ 4.2 GHz	± 2.0%	± 2.0%	± 2.0%	± 2.5%
2 GHz to ≤ 10 GHz		± 2.0%	± 2.0%	± 2.5%
10 GHz to ≤ 18 GHz		± 2.5%	± 2.3%	± 2.5%
18 GHz to ≤ 26.5 GHz			± 2.5%	± 2.8%
26.5 GHz to ≤ 50 GHz				± 4.5%

Specifications
N5532A Sensor Module Supplemental Information

4 Maintenance and Repair

Maintenance

Cleaning Solutions

A solution of pure isopropyl or ethyl alcohol can be used to clean the connector (keeping in mind its flammable nature).

Connector Cleaning

Clean the connector face using a cotton swab dipped in isopropyl alcohol. If the swab is too big, use a round wooden toothpick wrapped in a lint free cotton cloth dipped in isopropyl alcohol.

Repair

Tools required:

- 3/4-inch open end wrench
- 5/16-inch or 8 mm open end wrench (torque wrench preferred)
- 1/4-inch open end wrench
- 3/16-inch open end wrench
- 17 mm open end wrench
- 7 mm open end wrench
- 1.5 mm hex wrench
- 1/16-inch hex wrench
- 5/64-inch or 2 mm hex wrench
- Torx - 10 driver
- Needle-nose pliers
- Diagonal cutters

Assembly Replacement Procedures

Remove and Replace the Instrument Covers

Use this procedure to remove and replace the instrument covers for all sensor models.

1. Remove 4 screws and the bottom cover from the module assembly.
2. Locate the two aluminum deck blocks near the input connector. Notice that there is a left and right side block, and how they fit. Remove the deck blocks and separate the sensor module assembly from the plastic housing.

Figure 4-1 Deck Blocks



Maintenance and Repair

Repair

3. After parts replacement, place the assembly into the top housing. Place the right and left aluminum deck blocks into their correct positions and hand tighten. The deck blocks may need to be adjusted slightly if the plastic cover is difficult to install.
4. Place the bottom housing in position and secure with the four screws. The machine screws go in the two holes near the input connector. Hand tighten.

Power Sensor Replacement

If the power sensor requires replacement, 2 screws must be removed from the RF input connector flange of the replacement assembly. Prepare the replacement power sensor by removing the 2 screws using a 1.5-mm hex driver. Refer to [Figure 4-2](#) for location of screws. Note that the screws you need to remove are on the opposite end and opposite side of the notch in the power sensor cable connector.

Figure 4-2 Location of Screws to be Removed

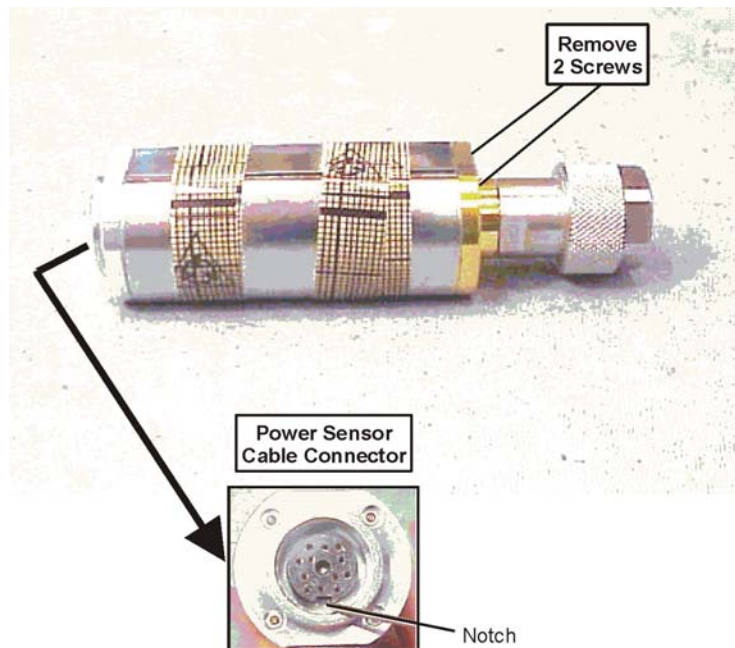

Options 504 and 518

Refer to [Figure 4-3](#) and [Figure 4-4](#) for part locations for Options 504 and 518. For earlier model sensors, refer to [Figure 4-5](#) and [Figure 4-6](#).

Figure 4-3 Options 504 and 518 Top View

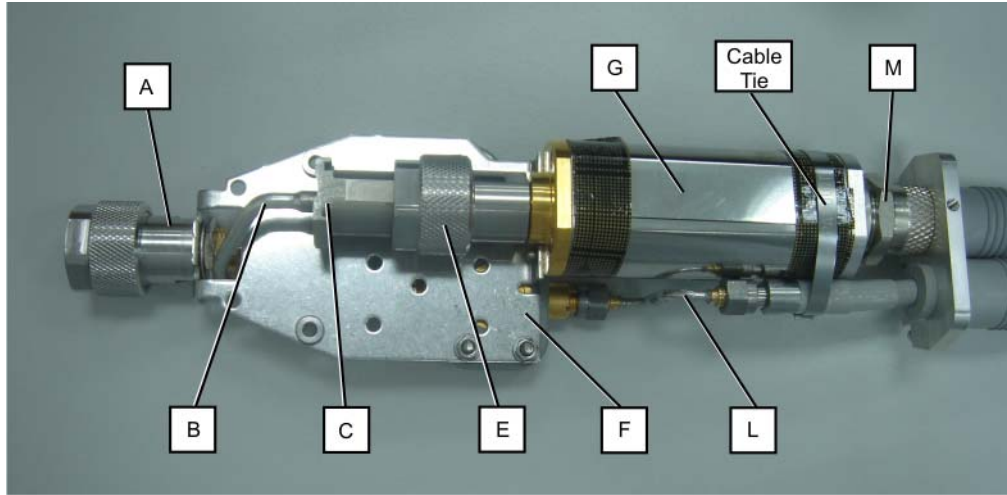
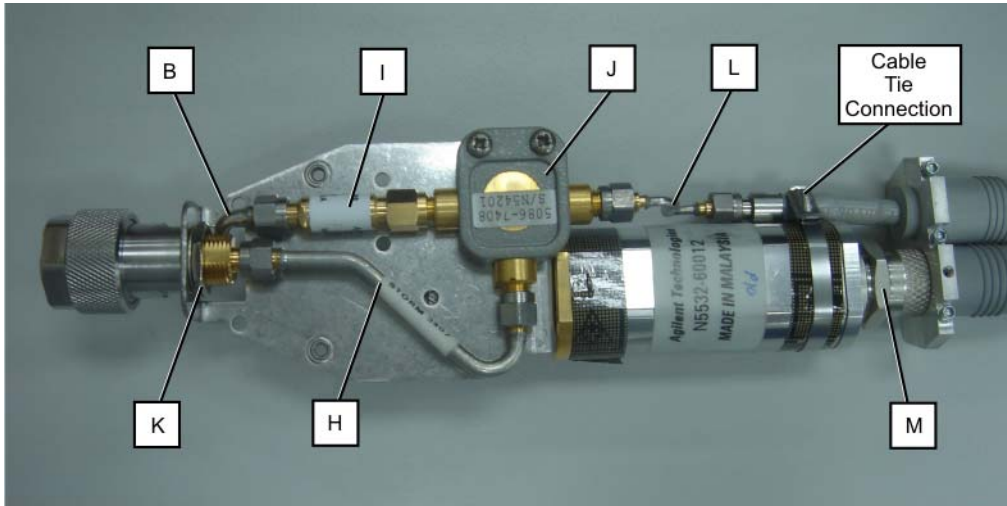

Figure 4-4 Options 504 and 518 Bottom View



A	Input connector, Type-N
B	Cable, attenuator to sensor
C	Connector (part of cable)
E	Power Sensor connector
F	Deck, main
G	Power sensor, 4.2 GHz or Power sensor, 18 GHz

H	Cable, input connector to splitter
I	3 dB attenuator
J	Power splitter
K	Hex Nut
L	Cable, splitter to output
M	Power Sensor Nut

Figure 4-5 Options 504 and 518 Top View
(Early Models)

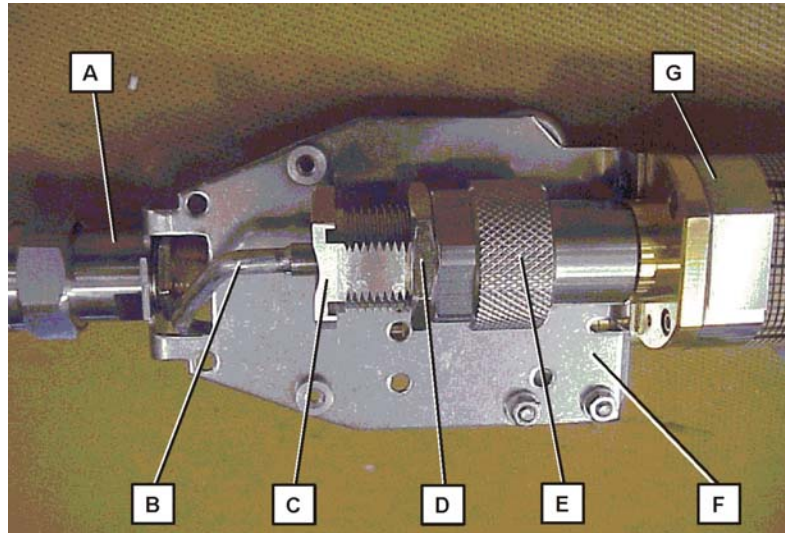
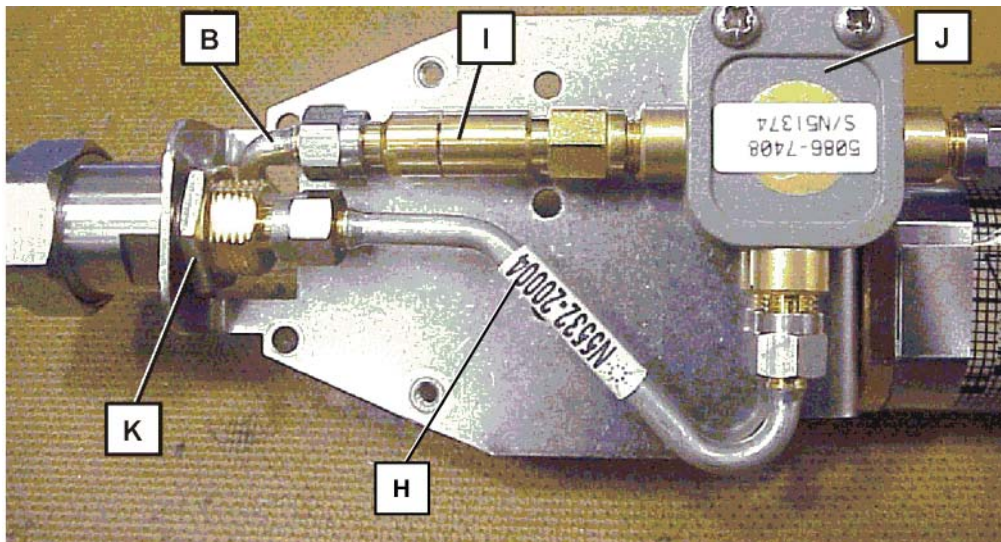

Figure 4-6 Options 504 and 518 Bottom View
(Early Models)



A	Input connector, Type-N	G	Power sensor, 4.2 GHz or Power sensor, 18 GHz
B	Cable, attenuator to sensor	H	Cable, input connector to splitter
C	Connector (part of cable)	I	3 dB attenuator
D	Nut	J	Power splitter
E	Power Sensor connector	K	Hex Nut
F	Deck, main		

Input Connector

1. To remove the input connector (A), first remove the input connector to splitter cable, (H), using a 5/16 inch wrench until the nut is disengaged from the input connector.
2. Using a large wrench, remove the hex nut (K) holding the input connector on the deck. Remove the input connector and washer.
3. To replace the input connector, line up the flat on the input connector with the flat on the main deck and slide the input connector into the main deck. Replace the lock washer and hex nut. Loosely attach the input connector to splitter cable, (H) to the input connector. Torque the hex nut (K) to 25 inch-lbs.
4. Torque the cable to 8 inch-lbs.

Power Splitter

1. To remove power splitter (J), loosen the cable connectors but do not remove the 2 cables or the 3 dB attenuator until the power splitter mounting screws are removed. Removing the mounting screws will allow the splitter to move around and reduce damage to the center conductors.
2. Cut the metal tie wrap. Remove the splitter to output cable (L) using a 7 mm wrench to hold the output connector while using a 5/16-inch wrench to remove the cable connector.
3. Remove the input to splitter cable (H).
4. Disconnect the splitter from the attenuator.
5. When installing the power splitter, connect to the 3 dB attenuator first. Then reinstall the input to splitter cable (H) and the splitter to output cable (L). Leave all connections loose at this time.
6. Put the 2 screws through the power splitter and deck. Holding the screws in place, turn the entire assembly upside down. Place the lock washers and hex nuts on the screws. Hold the hex nut with the 3/16-inch open end wrench and torque the screw to 3 inch-lbs. Then secure the screw with a manual driver and torque the nut to 3 inch-lbs.
7. Torque all cable connections to 8 inch-lbs.
8. Install a new metal cable tie.

Maintenance and Repair

Repair

Cable Tie Installation

The replacement cable tie secures the RF output cable to the power sensor. Use the stainless steel cable tie called out in the parts list. Do not use a plastic cable tie since it is too thick and will cause the instrument cover to crack.

NOTE

When installing the cable tie, care must be taken to avoid cutting your fingers. The cable tie can be installed using pliers and side cutters. See [Figure 4-4](#) for a typical installation of the cable tie. It is important to position the cable tie so that the flat part of the cable tie touches the top and bottom of the power sensor, and the cable tie connection is off to the side as shown. The actual position of the cable tie relative to the cable connection may vary between sensor module options.

Power Sensor

1. To remove the power sensor (G), first loosen the sensor connection to the attenuator to sensor cable, (B), holding the cable connector at (C) and loosening the sensor connection (E).
2. For earlier model sensors, refer to [Figure 4-4](#) and [Figure 4-5](#). To remove the attenuator to sensor cable, (B), hold connector (C) with 3/4-inch open-end wrench while loosening nut (D) and power sensor connector (E).
3. Disconnect the splitter to output cable, (L) at either end.
4. Remove the two screws attaching the sensor to the main deck.
5. Cut the metal tie wrap.
6. Loosen the nut (M) to remove the sensor from the cable.
7. Prepare the replacement power sensor as described on [page 24](#).
8. When fastening the power sensor (G) to the main deck (F), torque the 2 screws holding it to 3 inch-pounds.
9. Connect the power sensor connector (E) to the cable (B) and torque to 8 inch-pounds while holding connector (C) with a 3/4-inch open-end wrench. For earlier model sensors, it will be necessary to now tighten the locknut (D) against the sensor connector (E).
10. Install a new metal cable tie.

Attenuator

1. To remove the attenuator (I), loosen the connection between the attenuator and the attenuator to sensor cable, (B).
2. Remove the power splitter (J). After the power splitter is removed, the attenuator can be removed from the attenuator to sensor cable, (B).
3. To replace the attenuator, attach it to the power splitter but do not tighten.
4. Replace the power splitter into position, attaching the other 2 cables. Leave all connections loose at this time.
5. Put the 2 screws through the power splitter and deck. Holding the screws in place, turn the entire assembly upside down. Place the lock washers and hex nuts on the screws. Hold the hex nut with the 3/16-inch open end wrench and torque the screw to 3 inch-lbs. Then secure the screw with a manual driver and torque the nut to 3 inch-lbs.
6. Torque all cable connections to 8 inch-lbs.

Maintenance and Repair

Repair

Cables

1. The input connector (A) must be removed before the attenuator to sensor cable, (B) can be removed.
2. To remove the attenuator to sensor cable, (B), hold connector (C) with 3/4-inch open-end wrench while loosening the power sensor connector (E).
3. For earlier model sensors, refer to [Figure 4-4](#) and [Figure 4-5](#). To remove the attenuator to sensor cable, (B), hold connector (C) with 3/4-inch open-end wrench while loosening nut (D) and power sensor connector (E).
4. To replace the attenuator to sensor cable, (B), place it through the rectangular hole in the main deck (F) before installing the bulkhead connector (A). Place lock washer and nut (K) on bulkhead connector and torque to 25 inch-lbs.
5. Connect the cable to the attenuator and the other end to the sensor. Torque the attenuator end to 8 inch-lbs.
6. On the sensor end, hold connector (C) with 3/4-inch open-end wrench while tightening the power sensor connector (E). Torque to 8 inch-lbs.
7. For earlier model sensors, it will be necessary to now tighten the locknut (D) against the sensor connector (E).
8. To replace either of the other 2 cables, simply disconnect them at both ends. When replacing, torque all cable connections to 8 inch-lbs.

Option 526

Refer to [Figure 4-7](#) and [Figure 4-8](#) for part locations for Option 526.

Figure 4-7 Option 526 Top View

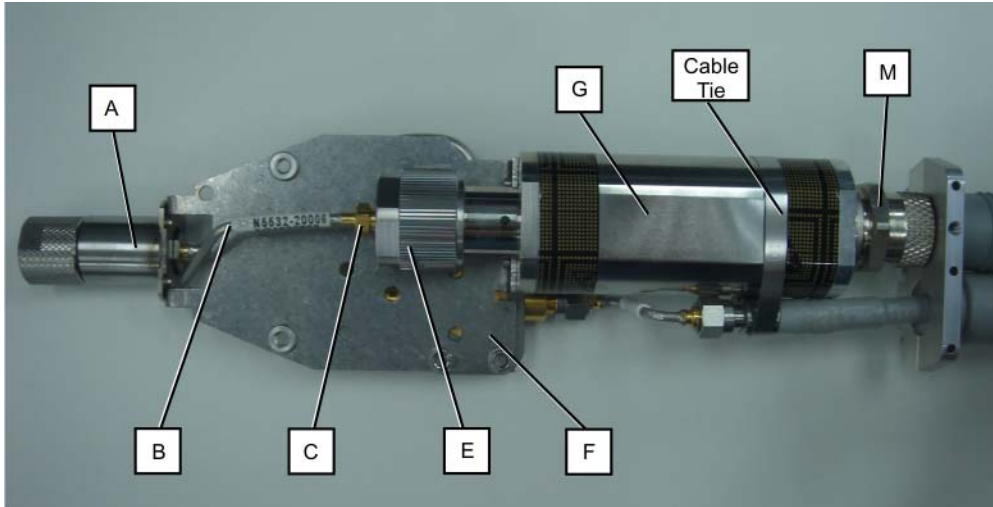
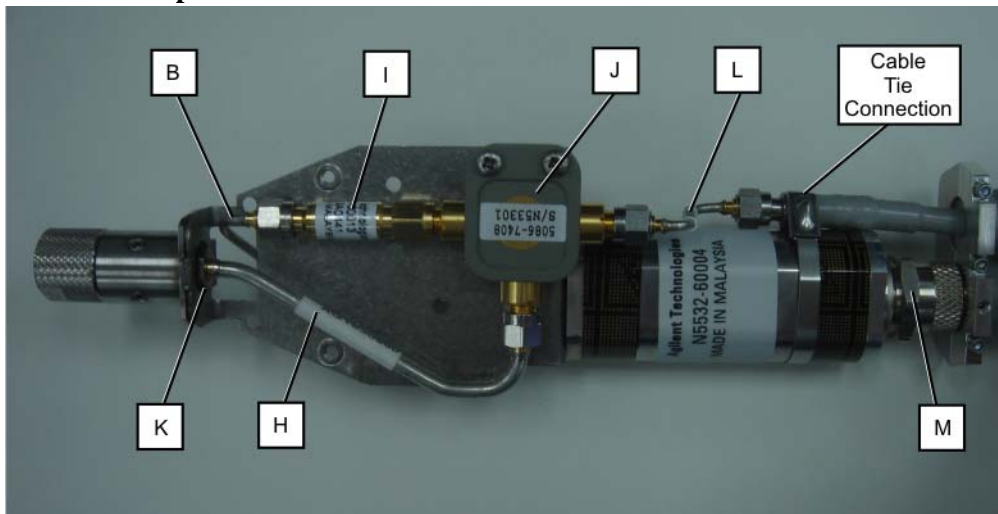

Figure 4-8 Option 526 Bottom View



A	Input connector, 3.5 mm	H	Cable, input connector to splitter
B	Cable, attenuator to sensor	I	3 dB attenuator, 26 GHz
C	Connector (part of cable)	J	Power splitter, 26.5 GHz
E	Power Sensor connector	K	Hex Nut
F	Deck, main	L	Cable, splitter to output
G	Power sensor, 26.5 GHz	M	Power Sensor Nut

Maintenance and Repair

Repair

Input Connector

1. Loosen but do not remove the two set screws in the input connector body (A), using a 1/16-inch hex wrench.
2. Locate the input connector to splitter cable, (H), and using a 5/16-inch wrench loosen the input connector nut about one turn. Avoid damaging the nut since it is difficult to get the wrench on fully.
3. Remove the nut on the splitter end of the input cable and disconnect the cable from the splitter.
4. Slide the input connector and cable out of the main deck, and replace the input connector. Assure the connections are clean. Attach the input cable loosely.
5. To replace the input connector, line up the flat on the input connector with the flat on the main deck and slide the input connector into the main deck.
6. Attach the input cable to the splitter.
7. Torque both ends of the cable to 8 inch-lbs.
8. Tighten the two set screws to secure the input connector to the main deck. Torque to 10 inch-lbs.

Power Splitter

1. To remove power splitter (J), loosen the cable connectors but do not remove the 2 cables or the 3 dB attenuator until the power splitter mounting screws are removed. Removing the mounting screws will allow the splitter to move around and reduce damage to the center conductors.
2. Cut the metal tie wrap. Remove the splitter to output cable (L) using a 7 mm wrench to hold the output connector while using a 5/16-inch wrench to remove the cable connector.
3. Remove the input to splitter cable (H).
4. Disconnect the splitter from the attenuator.
5. When installing the power splitter, connect to the 3 dB attenuator first. Then reinstall the input to splitter cable (H) and the splitter to output cable (L). Leave all connections loose at this time.
6. Put the 2 screws through the power splitter and deck. Holding the screws in place, turn the entire assembly upside down. Place the lock washers and hex nuts on the screws. Hold the hex nut with the 3/16-inch open end wrench and torque the screw to 3 inch-lbs. Then secure the screw with a manual driver and torque the nut to 3 inch-lbs.
7. Torque all cable connections to 8 inch-lbs.
8. Install a new metal cable tie.

Cable Tie Installation

The replacement cable tie secures the RF output cable to the power sensor. Use the stainless steel cable tie called out in the parts list. Do not use a plastic cable tie since it is too thick and will cause the instrument cover to crack.

NOTE

When installing the cable tie, care must be taken to avoid cutting your fingers. The cable tie can be installed using pliers and side cutters. See [Figure 4-8](#) for a typical installation of the cable tie. It is important to position the cable tie so that the flat part of the cable tie touches the top and bottom of the power sensor, and the cable tie connection is off to the side as shown. The actual position of the cable tie relative to the cable connection may vary between sensor module options.

Power Sensor

1. To remove the power sensor (G), first loosen the sensor connection to the attenuator to sensor cable, (B), holding the cable connector at (C) and loosening the sensor connection (E).
2. Disconnect the splitter to output cable, (L) at either end.
3. Remove the two screws attaching the sensor to the main deck.
4. Cut the metal tie wrap.
5. Loosen the nut (M) to remove the sensor from the cable.
6. Prepare the replacement power sensor as described on [page 24](#).
7. When fastening the power sensor (G) to the main deck (F), torque the 2 screws holding it to 3 inch-pounds.
8. Connect the power sensor connector (E) to the cable (B) and torque to 8 inch-pounds while holding connector (C) with a 3/4-inch open-end wrench.
9. Install a new metal cable tie.

Maintenance and Repair

Repair

Attenuator

1. To remove the attenuator (I), loosen the connection between the attenuator and the attenuator to sensor cable, (B).
2. Remove the power splitter (J). After the power splitter is removed, the attenuator can be removed from the cable, attenuator to sensor (B).
3. To replace the attenuator, attach it to the power splitter but do not tighten.
4. Replace the power splitter into position, attaching the other 2 cables. Leave all connections loose at this time.
5. Put the 2 screws through the power splitter and deck. Holding the screws in place, turn the entire assembly upside down. Place the lock washers and hex nuts on the screws. Hold the hex nut with the 3/16-inch open end wrench and torque the screw to 3 inch-lbs. Then secure the screw with a manual driver and torque the nut to 3 inch-lbs.
6. Torque all cable connections to 8 inch-lbs.

Cables

1. To remove the attenuator to sensor cable, (B), hold connector (C) with 1/4-inch open-end wrench while loosening the power sensor connector (E).
2. To replace the attenuator to sensor cable, (B), place it through the rectangular hole in the main deck (F).
3. Connect the cable to the attenuator and the other end to the sensor. Torque the attenuator end to 8 inch-lbs.
4. On the sensor end, hold connector (C) with 1/4-inch open-end wrench while tightening the power sensor connector (E). Torque to 8 inch-lbs.
5. To replace either of the other 2 cables, simply disconnect them at both ends. When replacing, torque all cable connections to 8 inch-lbs.

Option 550

Refer to [Figure 4-9](#) and [Figure 4-10](#) for part locations for Option 550.

Figure 4-9 Option 550 Top View

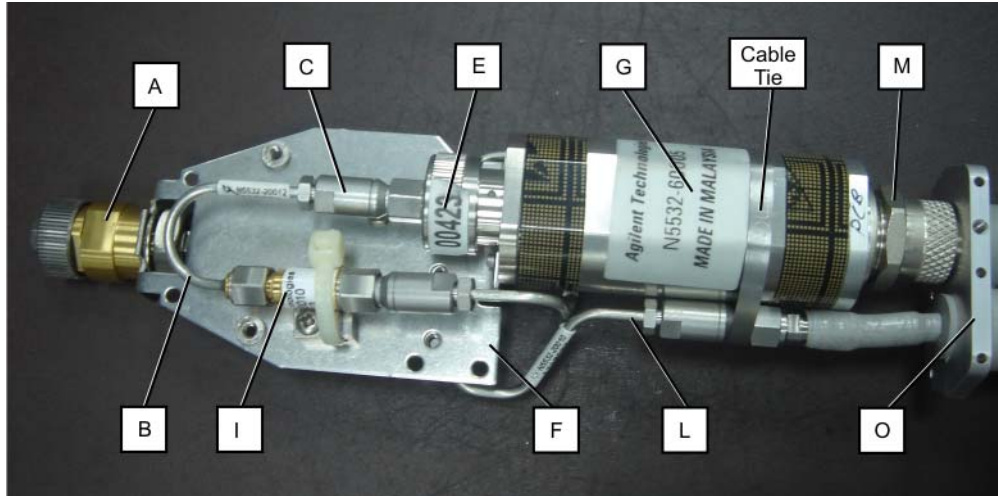
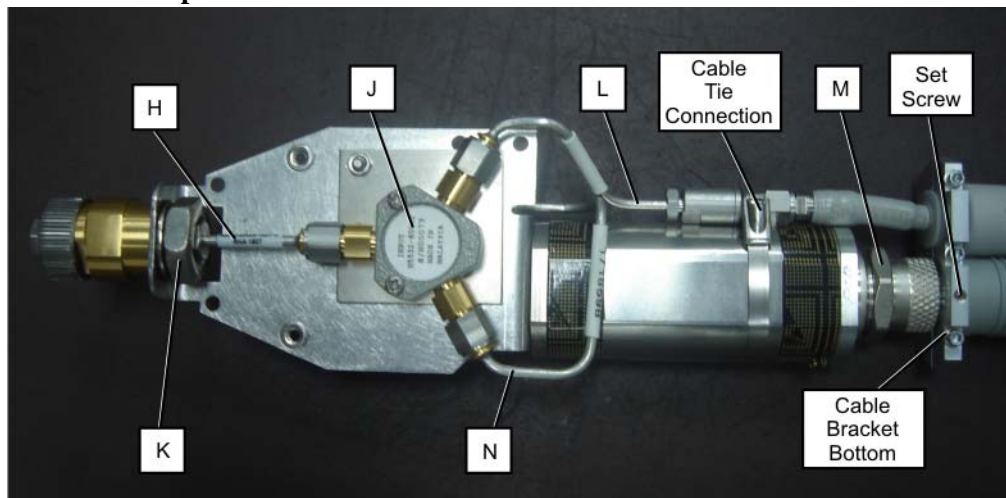

Figure 4-10 Option 550 Bottom View



A	Input connector, 2.4 mm
B	Cable, attenuator to sensor
C	Connector (part of cable)
E	Power Sensor connector
F	Deck, main
G	Power sensor, 50 GHz
H	Cable, RF input, 2.4 mm

I	3 dB attenuator, 50 GHz
J	Power splitter, 50 GHz
K	Hex Nut
L	Cable, splitter to output
M	Power Sensor Nut
N	Cable, splitter to attenuator
O	Bracket, cable (top)

Maintenance and Repair

Repair

Input Connector

1. To remove the input connector (A), first loosen the input connector to splitter cable, (H) on both ends using a 5/16-inch wrench.
2. Using a 17 mm wrench, remove the hex nut (K) holding the input connector on the deck.
3. Using a 5/16-inch wrench, remove the cable from the splitter.
4. Remove the input connector, washer, and cable.
5. To replace the input connector, line up the flat on the input connector with the flat on the main deck and slide the input connector into the main deck. Replace the lock washer and hex nut. Loosely attach the input connector to splitter cable, (H) to the input connector. Torque the hex nut to 25 inch-lbs.
6. Torque the input connector to splitter cable, (H) to 8 inch-lbs at both ends.

Power Splitter

1. To remove power splitter (J), loosen the cable connectors but do not remove the 3 cables until the power splitter mounting screws are removed. Removing the mounting screws will allow the splitter to move around and reduce damage to the center conductors.
2. Cut the metal tie wrap. Remove the splitter to output cable (L) using a 7 mm wrench to hold the output connector while using a 5/16-inch wrench to remove the cable connector.
3. Remove the input to splitter cable (H).
4. Disconnect the splitter from the splitter to attenuator cable (N).
5. When installing the power splitter, connect to the splitter to attenuator cable (N) first. Then reinstall the input to splitter cable (H) and the splitter to output cable (L). Leave all connections loose at this time.
6. Put the 2 screws through the power splitter and deck. Holding the screws in place, turn the entire assembly upside down. Place the lock washers and hex nuts on the screws. Hold the hex nut with the 3/16-inch open end wrench and torque the screw to 3 inch-lbs. Then secure the screw with a manual driver and torque the nut to 3 inch-lbs.
7. Torque all cable connections to 8 inch-lbs.
8. Install a new metal cable tie.

Cable Tie Installation

The replacement cable tie secures the RF output cable to the power sensor. Use the stainless steel cable tie called out in the parts list. Do not use a plastic cable tie since it is too thick and will cause the instrument cover to crack.

NOTE

When installing the cable tie, care must be taken to avoid cutting your fingers. The cable tie can be installed using pliers and side cutters. See [Figure 4-10](#) for a typical installation of the cable tie. It is important to position the cable tie so that the flat part of the cable tie touches the top and bottom of the power sensor, and the cable tie connection is off to the side as shown. The actual position of the cable tie relative to the cable connection may vary between sensor module options.

Power Sensor

1. To remove the power sensor (G), first loosen the sensor connection to the attenuator to sensor cable, (B), holding the cable connector at (C) with a 1/4-inch wrench and loosening the sensor connection (E) with a 5/16-inch wrench.
2. Disconnect the splitter to output cable, (L) at either end.
3. Remove the two screws attaching the sensor to the main deck.
4. Cut the metal tie wrap.
5. Loosen the nut (M) to remove the sensor from the cable.
6. Prepare the replacement power sensor as described on [page 24](#).
7. When fastening the power sensor (G) to the main deck (F), torque the 2 screws holding it to 3 inch-pounds.
8. Connect the power sensor connector (E) to the cable (B) and torque to 8 inch-pounds while holding connector (C) with a 1/4-inch open-end wrench.
9. Install a new metal cable tie.

Maintenance and Repair

Repair

Attenuator

1. To remove the attenuator (I), remove the attenuator to sensor cable, (B). Hold the cable connector at (C) with a 1/4-inch wrench and loosen the sensor connection (E) with a 5/16-inch wrench. On the attenuator end of the cable, hold the attenuator with a 5/16-inch wrench and loosen the cable with another 5/16-inch wrench.
2. Using a 1/4-inch wrench to hold the attenuator, loosen the splitter to attenuator cable (N) and remove the attenuator.
3. To replace the attenuator, attach it to the splitter to attenuator cable (N) but do not tighten.
4. Replace the attenuator to sensor cable, (B).
5. Torque all cable connections to 8 inch-lbs. Hold the cable connector at (C) with a 1/4-inch wrench and tighten the sensor connection (E) with a 5/16-inch wrench. On the attenuator end of the cable, hold the attenuator with a 5/16-inch wrench and tighten the cable with another 5/16-inch wrench.

Cables

1. To remove the input to splitter cable (H) it is necessary to remove the input connector. Refer to the input connector removal procedure.
2. To remove the attenuator to sensor cable, (B), hold connector (C) with 1/4-inch open-end wrench while loosening the power sensor connector (D) using a 5/16-inch open-end wrench. On the attenuator end of the cable, hold the attenuator with a 5/16-inch wrench and loosen the cable with another 5/16-inch wrench.
3. To remove the splitter to attenuator cable (N), hold the attenuator with a 5/16-inch wrench and use a 1/4-inch wrench to loosen the cable.
4. To remove the splitter to output cable (L), use a 5/16-inch wrench to disconnect it at both ends.
5. When replacing the cables, torque all cable connections to 8 inch-lbs.

Replaceable Parts

Table 4-1 N5532A Series Sensor Module Replaceable Parts

Description	Part Number	Opt 504 (4 GHz)	Opt 518 (18 GHz)	Opt 526 (26 GHz)	Opt 550 (50 GHz)
Power sensor adapter (same as N5532A Opt 019)	N5532-60013	X	X	X	X
Screw, metric, 3.0 x 0.50 Front screws for cover attachment	0515-0667	X	X	X	X
Screw, socket head cap, metric 1.6 x 0.35, 10 mm long For sensor mounting	0515-1185	X	X	X	X
Washer, lock, helical, #0, 0.062-in-ID, 0.1-in-OD For sensor mounting	2190-0572	X	X	X	X
Screw, tapping, 4-20, 0.835 inch long, pan head, TORX For support block mounting and rear screws for cover attachment	0624-0824	X	X	X	X
Screw, 4-40, 0.562 inch long, pan head, Pozidrive For power splitter mounting	2200-0091	X	X	X	
Washer, lock, #4, helical, 0.115-in-ID For power splitter mounting	2190-0003	X	X	X	
Screw, 2-56, 0.75 inch long, pan head, Pozidrive For power splitter mounting	0520-0137				X
Washer, lock, 3/8 inch, 0.384-in-ID For mounting 2.4 mm input connector	2190-0022				X
Hex nut, dbl chamfer, M10 x 1.0, 6 mm thick For mounting 2.4 mm input connector	0535-0992				X
Nut, 4-40, 0.063-in-thick For power splitter mounting	2260-0002	X	X	X	
Washer, lock, 7/16 inch, 0.439-in-ID For Type-N connector	2190-0104	X	X		

Maintenance and Repair
Repair

Table 4-1 N5532A Series Sensor Module Replaceable Parts

Description	Part Number	Opt 504 (4 GHz)	Opt 518 (18 GHz)	Opt 526 (26 GHz)	Opt 550 (50 GHz)
Hex nut, UNEF-2B-THD, 0.094-in-thick For Type N connector	2950-0132	X	X		
Washer, lock, helical, #2, 0.088-in-ID For cable bracket	2190-0112	X	X	X	X
Screw, socket head cap, 2-56, 0.25-in-long For cable bracket	3030-0053	X	X	X	X
Setscrew, 4-40, 0.25-in-long For sensor cable bracket (see Figure 4-10)	3030-0824	X	X	X	X
Setscrew, 6-32, 0.125-in-long For input connector	3030-0022			X	
Hex nut, 2-56, 0.062-in-thick For power splitter mounting	0610-0002				X
Deck, main	N5532-00001	X	X		X
Deck, main (526)	N5532-20001			X	
Cable tie 0.18 Strp WD stainless steel	1400-3340	X	X	X	X
Deck support block (right)	N5532-20021	X	X	X	X
Deck support block (left)	N5532-20022	X	X	X	X
Spacer, for splitter	N5532-20003				X
Bracket, cable (top) (see Figure 4-9)	11722-20006	X	X	X	X
Bracket, cable (bottom) (see Figure 4-10)	11722-20007	X	X	X	X
Cover, plastic (top)	11722-40001	X	X	X	X
Cover, plastic (bottom)	11722-40002	X	X	X	X
Cable clip For sensor and RF output cables	11722-40003	X	X	X	X
Label, option ID	5185-1867	X	X	X	X
Label, product ID	N5532-80004	X	X	X	X
3 dB attenuator, 26 GHz	08493-60013	X	X	X	

Table 4-1 N5532A Series Sensor Module Replaceable Parts

Description	Part Number	Opt 504 (4 GHz)	Opt 518 (18 GHz)	Opt 526 (26 GHz)	Opt 550 (50 GHz)
3 dB attenuator, 50 GHz	08490-60010				X
Input connector, Type-N	N5532-60015	X	X		
Input connector, 3.5 mm	08673-60402			X	
Input connector, 2.4 mm	N5532-20015				X
Power splitter, 26.5 GHz	5086-7408	X	X	X	
Power splitter, 50 GHz	N5532-60002				X
Power sensor, 4.2 GHz	N5532-60011	X			
Power sensor, 18 GHz	N5532-60012		X		
Power sensor, 26.5 GHz	N5532-60004			X	
Power sensor, 50 GHz	N5532-60005				X
Cable, input connector to splitter	N5532-20004	X	X		
Cable, input connector to splitter	N5532-20007			X	
Cable, RF input, 2.4 mm	N5532-20009				X
Cable, splitter to output	N5532-20018	X	X	X	
Cable, splitter to output	N5532-20010				X
Cable, splitter to attenuator	N5532-20011				X
Cable, attenuator to sensor	N5532-20012				X
Cable, attenuator to sensor	N5532-20006			X	
Cable, attenuator to sensor	N5532-20019	X	X		
Cable, sensor output, shielded	N5532-60010	X	X	X	X
Cable, RF output, 3.5 mm, 66 inches long	N5532-20013	X	X	X	
Cable, RF output, 2.4 mm, 66 inches long	N5532-20017				X

Calibration

Agilent Technologies recommends that repair and calibration of the N5532A Sensor modules be performed at an Agilent Technologies service center. The service center has the required calibration standards and the ability to produce a calibration data disk in the format that the N5531S or N5530S Measuring Receiver System requires.

However, if your cal lab currently calibrates Agilent thermocouple power sensors such as the 8481A, 8482A, or 8487A, and the calibration standards and test metrology used meet the N5532A specifications listed in [Table 3-1 on page 16](#), you may wish to develop your own calibration process. Refer to Agilent Technologies Application Notes 1449-1 through 1449-4 for information regarding the fundamentals of RF and microwave power measurements. Application Note 1449-1 includes an overview of the theory and practice of sensor calibration.

[Figure 1-1 on page 7](#) shows that the N5532A Sensor Modules consist basically of a power splitter and an Agilent 848xA Power Sensor with a padded input. Therefore, the match of the N5532A Sensor Module is different than the match of a standard 848x Power Sensor. The module is calibrated with the RF Output cable terminated with a matched 50 Ω load.

The calibration power at the input should be 0 dBm \pm 2 dB. This is to ensure enough power is provided so the sensing element in the N5532A Sensor Module stays above its noise floor. The maximum calibration must not exceed +10 dBm to avoid non-linearities in the calibration standards (reference sensor or standard sensor).

The presence of the splitter and cable create a ripple in the sensor's input efficiency, so many frequency calibration points are required to accurately characterize the sensor module.

Figure 4-11

Cal Factor (Ripple Due to Splitter and PSA Line Loading)

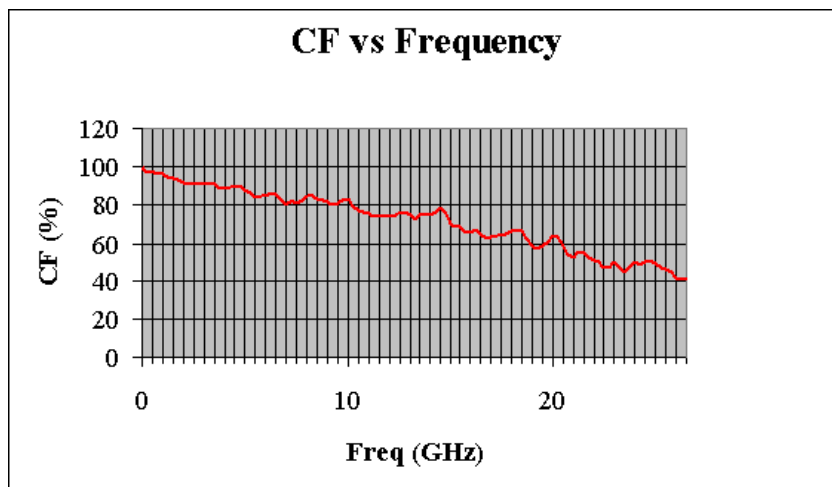

Table 4-2 Recommended Calibration Points

N5532A Power Sensor	Frequency Points
Option 504	100 kHz
	300 kHz
	1 MHz
	3 MHz
	5 MHz
	10 MHz
	30 MHz
	50 MHz
	100 MHz to 4.2 GHz in 100 MHz steps (50 steps)
Option 518	10 MHz
	30 MHz
	50 MHz
	100 MHz to 18 GHz in 100 MHz steps (183 steps)
Option 526	30 MHz
	50 MHz
	100 MHz to 26.5 GHz in 100 MHz steps (267 steps)
Option 550	30 MHz
	50 MHz
	100 MHz to 50 GHz in 100 MHz steps (501 steps)

Maintenance and Repair

Calibration

Typical Cal Factor ranges for the 848xA Power Sensors are between 90% and 100%, depending on the efficiency of the sensor's thermocouple over the specified frequency range. With the added loss from the other passive components in front of the power sensor, there is approximately another 9 to 11 dB loss (or another 25% loss) from 50 MHz to 26.5 GHz. This, coupled with the fact that typical power sensor Cal Factor is defined with a constant power level at the input, and this application has a sloped power input, an additional 25% efficiency component is added. As a result, the N5532A Sensor Module will have about a 40% Cal Factor at 26.5 GHz and about a 30% Cal Factor at 50 GHz. This is acceptable because the sensor is characterized with this behavior and thus will be corrected in the N5531S/30S Measuring Receiver System.

Upon calibrating the sensor module, the cal factor data is stored on a floppy disk. This disk allows you to transfer the cal data to the N5531S or N5530S Measuring Receiver System. Since there are hundreds of data points, manual entry is highly impractical.

Cal Factor Data File Format

The N5532A data, "CFData.xml", is stored in an xml format. On each data disk, the data file is accompanied with an xsl file, "CalTable.xsl". This file contains the xml formatting instructions which are used by an xml viewer, such as Microsoft Internet Explorer. However, the xml file may be viewed by any text editor and will appear as shown below.

The system software does not need the xsl file because it's not trying to display the data. The system, however, does look for the specific "bookmarks" or "tags" used by the xml format. So, for the system to properly read the data from the file, the calibration data needs to be stored as shown in the following sample file.

Figure 4-12 File Format for the N5532A Sensor Module Data Disk (Two Data Points Shown)

```
<?xml version="1.0" encoding="utf-8"?>
<!--This file is used with the Agilent N5532A power sensor module.-->
<?xml-stylesheet type="text/xsl" href="CalTable.xsl"?>
<Calibration>
  <Version>1.0</Version>
  <ModelNumber>N5532A</ModelNumber>
  <Options>526</Options>
  <SerialNumber>US00010004</SerialNumber>
  <DateCalibrated>7/22/2004</DateCalibrated>
  <ReferenceCF>99</ReferenceCF>
  <CalFactor>
    <Frequency Unit= "Mhz">30</Frequency>
    <CalFactor Unit= "Percent">99.5127892581548</CalFactor>
    <CalFactorUnc Unit= "Percent">1.73435915811032</CalFactorUnc>
    <ReflectionMag Unit= "Linear">6.23774528503418E-03</ReflectionMag>
    <ReflectionPhase Unit= "Degrees">-82.1718749999999</ReflectionPhase>
    <ReflectionMagUnc Unit= "Linear">1.10418066980155E-03</ReflectionMagUnc>
  </CalFactor>
  <CalFactor>
    <Frequency Unit= "Mhz">50</Frequency>
    <CalFactor Unit= "Percent">99</CalFactor>
    <CalFactorUnc Unit= "Percent">1.24220367426375</CalFactorUnc>
    <ReflectionMag Unit= "Linear">8.19176435470581E-04</ReflectionMag>
    <ReflectionPhase Unit= "Degrees">65.3320312499999</ReflectionPhase>
    <ReflectionMagUnc Unit= "Linear">2.91455027642453E-03</ReflectionMagUnc>
  </CalFactor>
</Calibration>
```

The structure of the file is as follows:

- The first 3 lines are for the xml format.
- The fourth line marks the start of the calibration data, while the last line marks the end of the calibration data.
- The next 5 lines contain sensor-specific information: data format version, model number, option, serial number, and date calibrated.
- The next line is the reference calibration factor.
- The rest of the data file is filled with frequency-dependent data. There are 6 lines for every data point and each data point is marked by the beginning `<CalFactor>` and the ending `</CalFactor>`. The data set includes frequency, cal factor, cal factor uncertainty, reflection magnitude, reflection phase, and reflection magnitude uncertainty.

Contacting Agilent Technologies

Agilent Technologies has offices around the world to provide you with complete support for your accessories. To obtain servicing information or to order replacements, contact the nearest Agilent Technologies office listed in [Table 4-3 on page 48](#). In any correspondence or telephone conversations, refer to your accessory by its product number and full serial number.

Table 4-3 **Contacting Agilent Technologies**

Online assistance: www.agilent.com/find/assist

United States

(tel) 1 800 829-4444

Latin America

(tel) (305) 269 7500

(fax) (305) 269 7599

Canada

(tel) 1 877 894 4414

(fax) (905) 282-6495

Japan

(tel) (81) 426 56 7832

(fax) (81) 426 56 7840

Europe

(tel) (31 20) 547 2323

(fax) (31 20) 547 2390

Australia

(tel) 1 800 629 485

(fax) (61 3) 9210 5947

New Zealand

(tel) 0 800 738 378

(fax) 64 4 495 8950

Asia Pacific

(tel) (852) 3197 7777

(fax) (852) 2506 9284