

**ENGR-4300**  
**Spring 2007**  
**Test 1B**

Name SOLUTION

Section 2

Question I (20 points) \_\_\_\_\_

Question II (22 points) \_\_\_\_\_

Question III (20 points) \_\_\_\_\_

Question IV (20 points) \_\_\_\_\_

Question V (18 points) \_\_\_\_\_

Total (100 points) \_\_\_\_\_

On all questions: SHOW ALL WORK. BEGIN WITH FORMULAS, THEN SUBSTITUTE VALUES AND UNITS. No credit will be given for numbers that appear without justification.

## Question I. Resistive circuits (20 points)

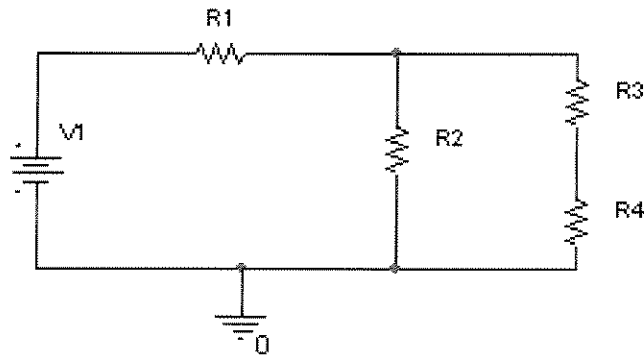

Given:  $V_1 = 10\text{volts}$ ,  $R_1 = 2000\Omega$ ,  $R_2 = 1000\Omega$ ,  $R_3 = 1200\Omega$ ,  $R_4 = 1800\Omega$ .

1) Find the total resistance of the circuit, seen from the voltage source. (6 pts)

$$R_1 + \frac{R_2 // (R_3 + R_4)}{1} = R_T \quad R_T = 2000 + \frac{(1000)(1200 + 1800)}{1000 + 1200 + 1800} \quad 750$$

$$R_1 + \frac{R_2(R_3 + R_4)}{R_2 + R_3 + R_4} = R_T \quad = 2000 + \frac{(1000)(3000)}{4000} = 2000 + \frac{1}{4} \times 3000$$

$$R_T = 2750 \Omega \quad \leftarrow \text{Answer: } +2$$

correct formula derived = +4

2) Find the voltage across  $R_1$ . (4 pts)

$$R_2 // (R_3 + R_4) \rightarrow \frac{R_2(R_3 + R_4)}{R_2 + R_3 + R_4} = 750 \Omega$$

$$R_1 = 2000 \Omega$$

$$V_{R_1} = V_1 \cdot \frac{R_1}{R_1 + (R_2 // (R_3 + R_4))} = 10V \cdot \frac{2000}{2000 + 750} = 10V \cdot \frac{2000}{2750} = 7.27V$$

Answer = +2

correct formula +2

3) Find the current through  $R_3$ . (4 pts)

$$\text{Voltage drop across } R_3 + R_4 = V_1 - V_{R_1} = 10V - 7.27V = 2.73V$$

$$\text{current flow } R_3 + R_4 = \frac{2.73V}{R_3 + R_4} = \frac{2.73}{3000} = 0.91 \text{ mA}$$

method: +3 pts

Answer: +1 pt

4) All the resistors ( $R_1$ ,  $R_2$ ,  $R_3$  and  $R_4$ ) have a gold band at the end of the color bands. This implies a certain manufacturing tolerance level for the resistor. Based on this tolerance level, compute the minimum current that could flow in the circuit. (6 pts)

For minimum current, all resistors have to be maximum value

$$\text{Gold} = \pm 5\% \text{ tolerance}$$

$$R_1 (+5\%) = 2000 + \frac{5}{100} \times 2000 = 2100 \Omega$$

$$R_2 (+5\%) = 1000 + \frac{5}{100} \times 1000 = 1050 \Omega$$

$$R_3 (+5\%) = 1200 + \frac{5}{100} \times 1200 = 1260 \Omega$$

$$R_4 (+5\%) = 1800 + \frac{5}{100} \times 1800 = 1890 \Omega$$

correct use  
of tolerance

4 pts

$$R_T = R_1 + \frac{R_2(R_3 + R_4)}{R_2 + R_3 + R_4}$$

← correct  $R_4$  + 1 pt

$$= 2100 + \frac{1050(1260 + 1890)}{1050 + 1260 + 1890} = 2100 + 787.5 \Omega$$

$$= 2887.5 \Omega$$

$$I_{\min} = \frac{V_1}{R_T} = \frac{10V}{2887.5 \Omega} = 3.46 \text{ mA}$$

← correct

Answer = +1 pt

Question II – Filters (22 points)

$$Z_C(1\text{kHz}) \approx -j160$$

$$50 + -j160 \approx 180 \angle -70^\circ$$

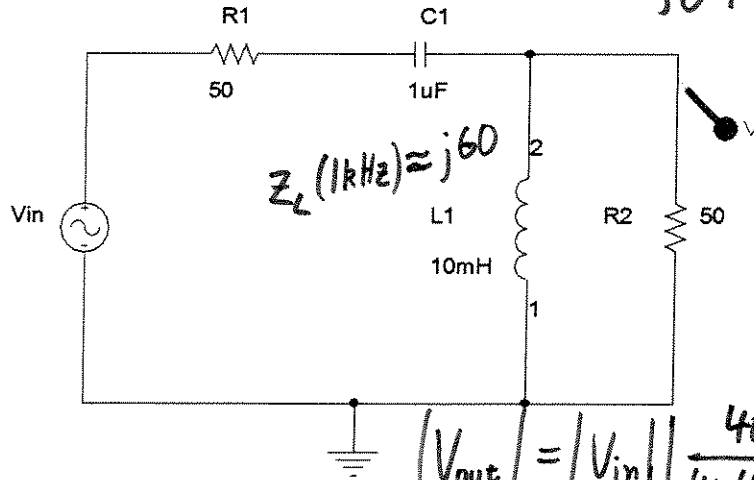

$$j60 || 50 \approx \frac{(j60)(50)}{j60 + 50} \approx 40 \angle 40^\circ$$

$$|V_{out}| = |V_{in}| \left| \frac{40 \angle 40^\circ}{40 \angle 40^\circ + 180 \angle -70^\circ} \right| \approx 1 \cdot \frac{1}{3}$$

1) Given the circuit shown, which graph would best represent the output seen across resistor R2; where  $V_{in} = 1V \cos(2\pi ft)$ , with  $f = 1\text{kHz}$ ? (4 pts)

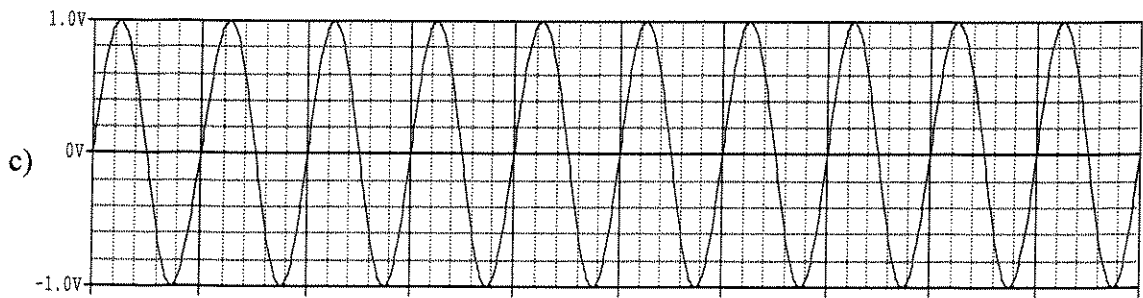
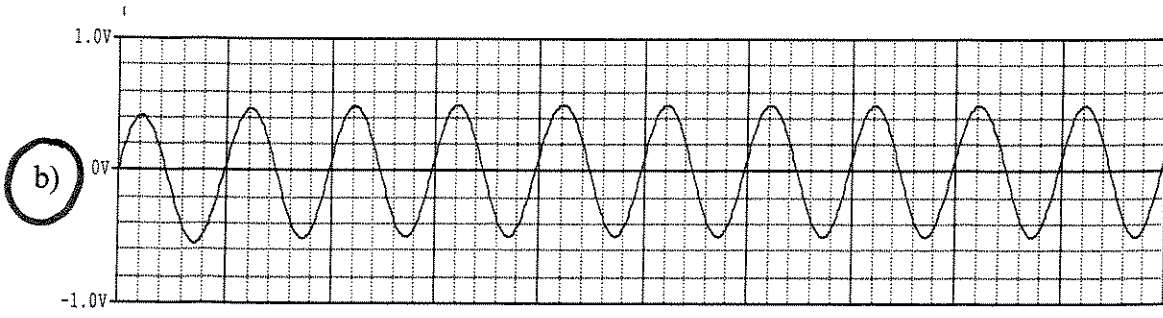
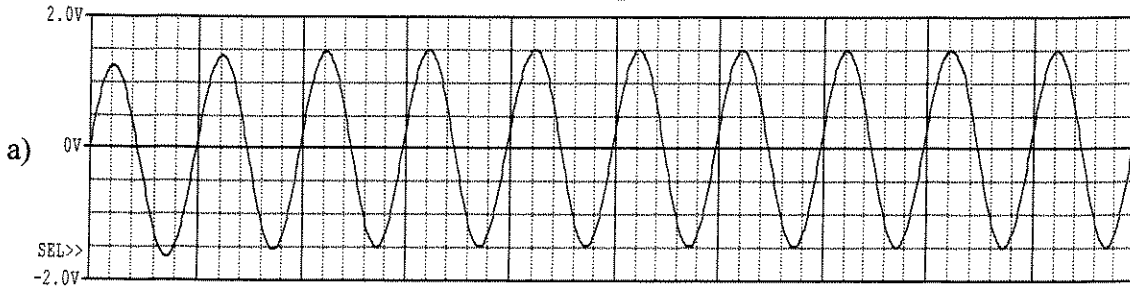

↓  
b)

Time

2) Given the circuit shown, which is the most likely voltage measured across resistor R2 if  $V_{in} = 1V \cos(2\pi ft)$ , with  $f = 1\text{Hz}$ ? (Please circle one.) (4 pts)

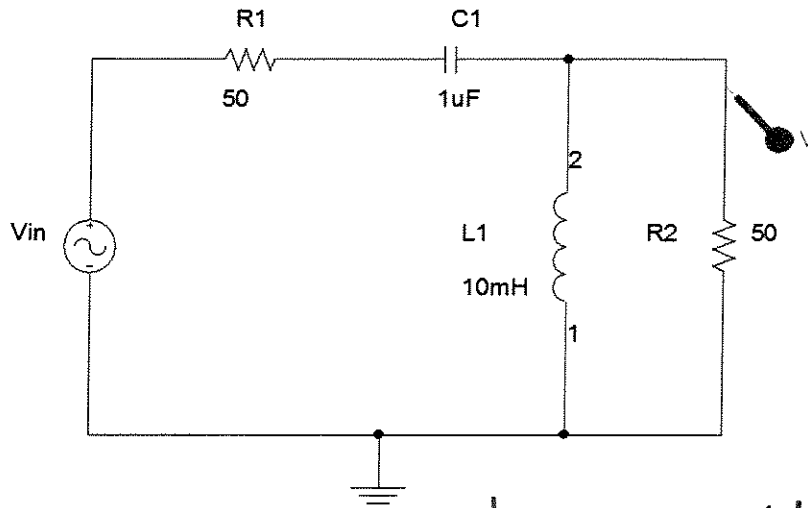

- a) 1V
- b) 0.5V
- c) 0V
- d) 2V

$$Z_c(1\text{Hz}) = \frac{1}{j2\pi(1)(10^{-6})} = -j160k$$

$$50 + -j160k \approx -j160k$$

$$Z_L(1\text{Hz}) = j2\pi(1)(0.01) = j0.06$$

$$50 \parallel j0.06 \approx 0$$

$$V_{out} = 1V \frac{0}{0 - j160k} \approx 0V$$

3) Given the circuit in 2), which is the most likely voltage measured across resistor R2 if  $V_{in} = 1V \cos(2\pi ft)$ , with  $f = 100\text{kHz}$ ? (Please circle one.) (4 pts)

- a) 1v
- b) 0.5v
- c) 0v
- d) 2v

$$Z_c(100\text{kHz}) = \frac{1}{j2\pi(100k)(10^{-6})} = -j1.6$$

$$50 + -j1.6 \approx 50$$

$$Z_L(100\text{kHz}) = j2\pi(100k)(0.01) = j6k$$

$$50 \parallel j6k \approx 50$$

$$V_{out} = 1V \frac{50}{50 + 50} \approx 0.5V$$

4) What kind of filter response would best represent this circuit? (Please circle one.) (4 pts)

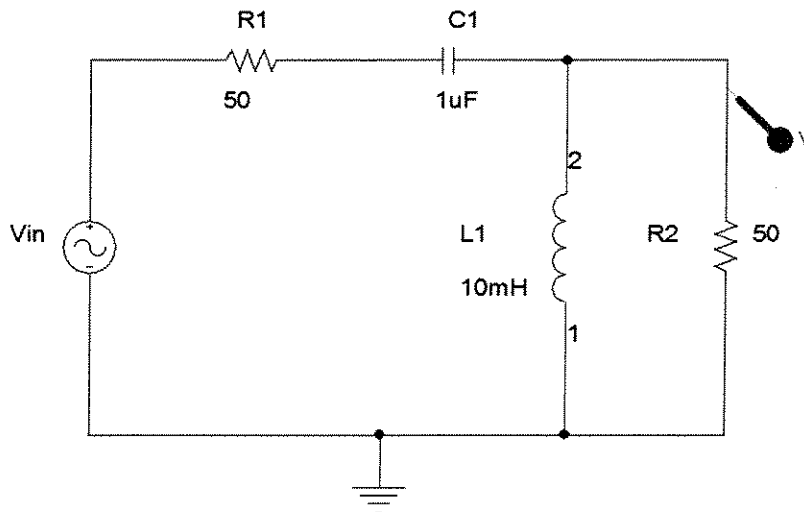

- a) Low Pass
- b) Band Pass
- c) High Pass
- d) Band Reject

5) What kind of response would result if the capacitor and inductor positions were swapped in the circuit? (Please circle one) (4 pts)

- a) Low Pass
- b) Band Pass
- c) High Pass
- d) Band Reject

6) What is the resonant frequency of the circuit in Hz? (2 pts)

$$\omega = \frac{1}{\sqrt{LC}} = \frac{1}{\sqrt{10\text{m} \cdot 1\mu}} = 10\text{k}$$

$$f = \frac{\omega}{2\pi} = \frac{10\text{k}}{2\pi} = \underline{\underline{1.59\text{kHz}}}$$

## Question III – Transfer Functions (20 points)

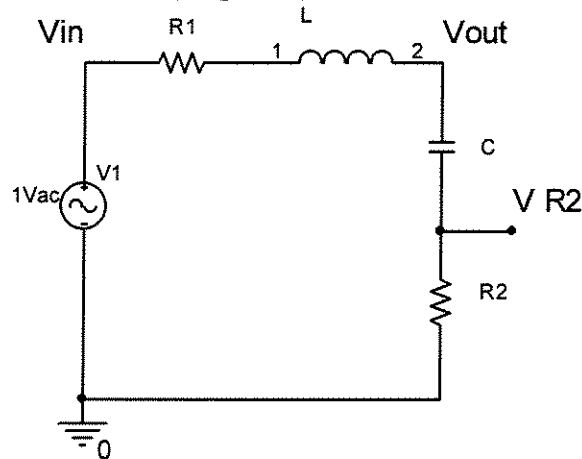

- 1) What is the transfer function ( $V_{out}/V_{in}$ ) for the circuit in terms of  $R_1$ ,  $R_2$ ,  $L$ , &  $C$ ? You must simplify. (6 pts)

$$\frac{V_{out}}{V_{in}} = \frac{\frac{1}{j\omega C} + R_2}{\frac{1}{j\omega C} + R_2 + j\omega L + R_1} = \frac{1 + j\omega R_2 C}{\underline{\underline{1 - \omega^2 LC + j\omega C(R_1 + R_2)}}}$$

- 2) What is the simplified transfer function of the circuit at low frequencies? (3 pts)

$$\frac{1}{1} = \underline{\underline{1}}$$

3) What is the simplified transfer function of the circuit at high frequencies? (3 pts)

$$\frac{j\omega R_2 C}{-\omega^2 LC} = \underline{\underline{-j \frac{R_2}{\omega L}}}$$

### Resonance

4) Find the frequency  $\omega_0$  (in terms of L & C) where the impedance of the inductor and capacitor ( $Z_L$  &  $Z_C$ ) have the same magnitude (but opposite signs) and cancel each other. (2 pts)

$$\frac{1}{\omega_0 C} = \omega_0 L \quad \omega_0^2 = \frac{1}{LC}$$

$$\omega_0 = \underline{\underline{\frac{1}{\sqrt{LC}}}}$$

5) How does the frequency in 4) compare to the circuit's resonant frequency? (2 pts)

FOR  $R=0$   $\omega_0$  IS RESONANT FREQ.

$R>0$   $\omega_0$  WILL BE GREATER THAN ACTUAL PEAK

6) What is the value of the transfer function  $\frac{V_{R2}(j\omega_0)}{V_{in}(j\omega_0)}$  at this frequency  $\omega_0$ ? (2 pts)

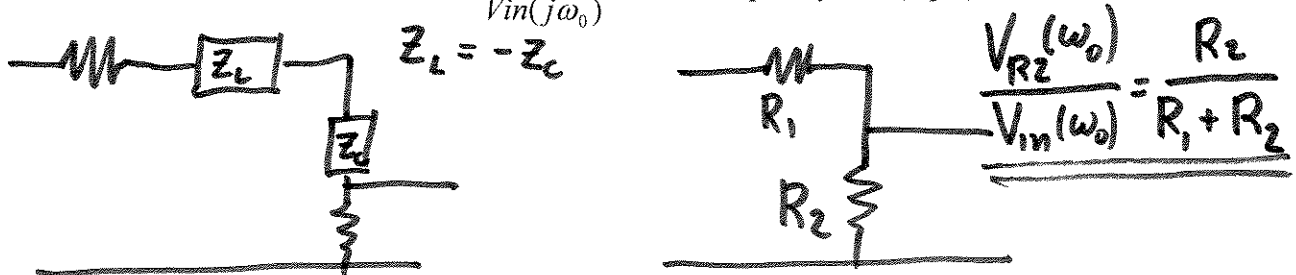

7) For  $V_{in}(t) = 2\sin(\omega_0 t + \pi/2)$  where  $\omega_0$  is the frequency found in 4), what is  $V_{R2}(t)$ ? (2 pts)

$$\underline{\underline{V_{R2}(t) = \frac{2 R_2}{R_1 + R_2} \sin(\omega_0 t + \frac{\pi}{2})}}$$



## Question IV – Signals, Transformers and Inductors (20 points)

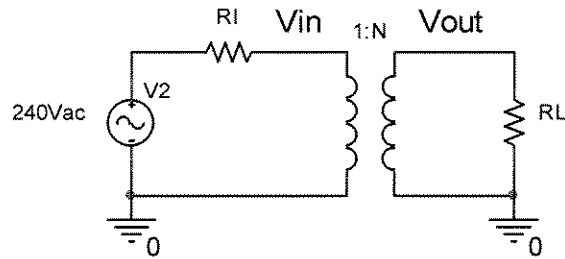

1) Given the circuit above, assume an ideal transformer with full coupling. With  $R_I = R_L = 100\Omega$  and  $N=1$ , find  $V_{in}$ ,  $V_{out}$ , and the power in  $R_L$ . (6 pts)

$$N \cdot V_{in} = V_{out} \quad \text{FOR } 1:1 \quad V_{in} = V_{out}$$

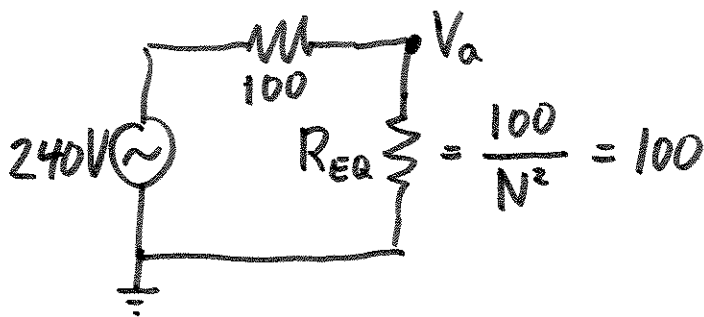

$$V_a = 240 \frac{100}{100 + 100} = 120V$$

$$V_{in} = V_a = \underline{\underline{120V}}$$

$$V_{out} = V_{in} = \underline{\underline{120V}}$$

$$P = \frac{V^2}{R} = \frac{(120)^2}{100} = \underline{\underline{144W}}$$

2) If  $R_L$  is changed to  $25\Omega$  (everything else remains as in 1), what are the new values for  $V_{in}$ ,  $V_{out}$ , and the power in  $R_L$ ? (6 pts)

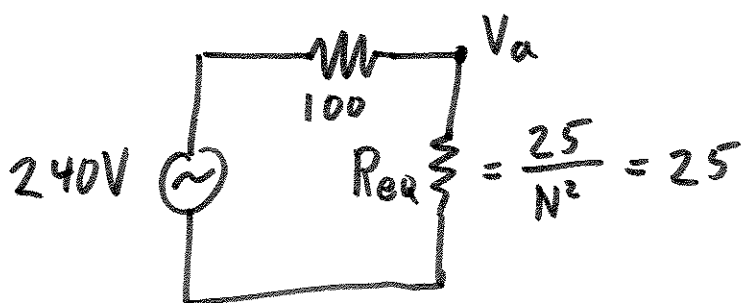

$$V_{out} = V_{in}$$

$$V_a = 240 \frac{25}{25 + 100} = 48V$$

$$V_{in} = V_a = \underline{\underline{48V}}$$

$$V_{out} = V_{in} = \underline{\underline{48V}}$$

$$P = \frac{V^2}{R} = \frac{(48)^2}{25} = \underline{\underline{92.2W}}$$

3) Find the value for  $N$  that allows the circuit in 2) to see the same load on the primary (source) side of the transformer as in 1). (4 pts)

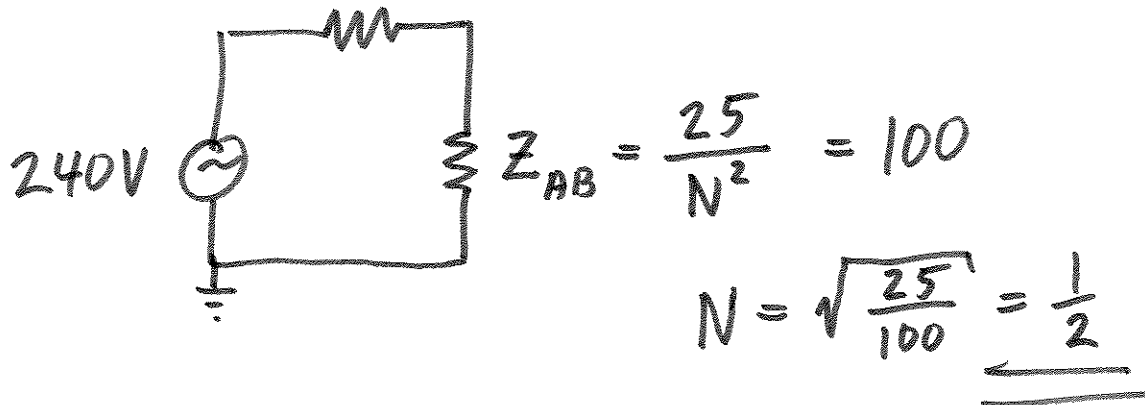

4) Knowing that a real transformer's behavior deviates from that of an ideal, what would be an appropriate minimum value for the inductance on the primary of the transformer in 1), given the source's frequency of 60Hz? (4 pts)

- a) 0.003mH
- b) 0.3mH
- c) 30mH
- d) 3H

FOR IDEAL TRANSFORMER

$$|Z_L| \gg R$$

$$|j\omega L| \approx 10 \times R$$

$$L \approx \frac{10R}{\omega} = \frac{10 \cdot 100}{2\pi \cdot 60} = 2.65 \text{ H}$$

$\Downarrow$   
 3H

Question V – Instrumentation, PSpice and components (18 points)

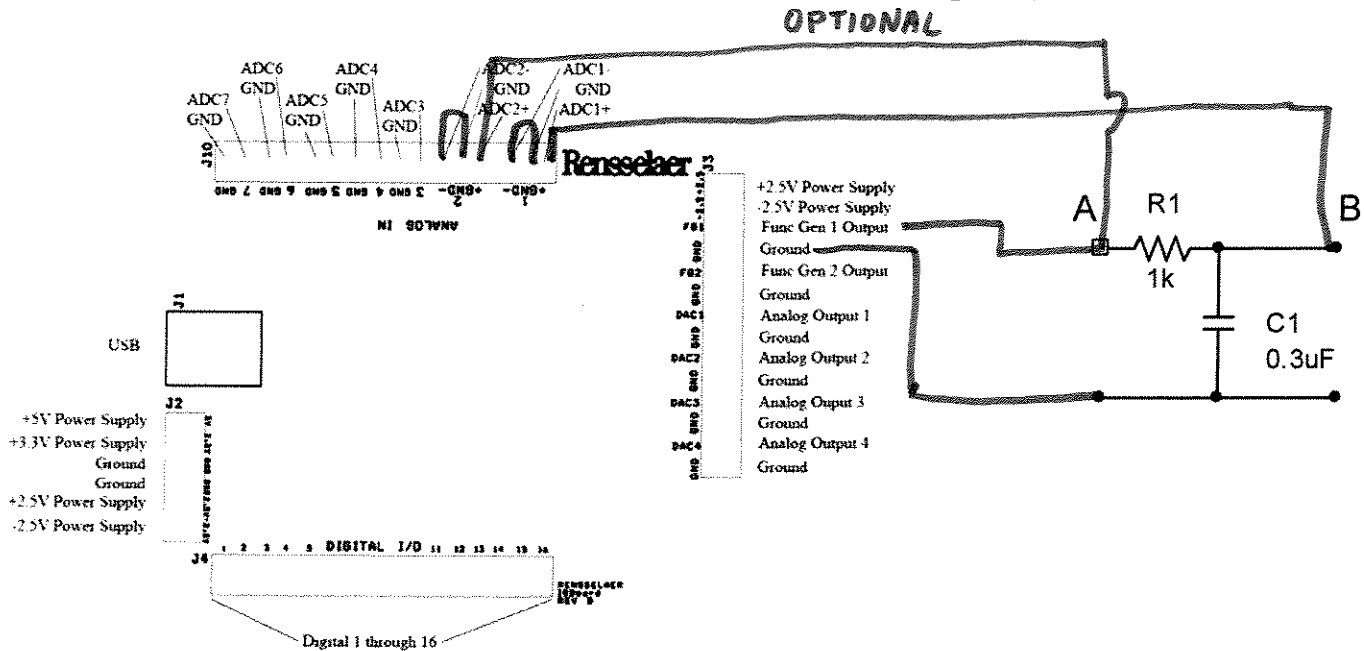

You are asked to generate a  $0.8V_{p-p}$  50Hz triangle wave on function generator 1 and display its waveform on channel 2 of the oscilloscope. The signal is to be fed into the RC low pass filter shown above (A) and the output of the filter (B) displayed on channel 1 of the oscilloscope.

- 1) Draw **all** the lines on the above figure to represent the wires needed to see the desired waveforms. (4 pts)
- 2) To what value should the function generator's amplitude be set for this? (2 pts)

0.4V       $V_{AMP} = \frac{1}{2} V_{P-P}$

- 3) It is desired to see 5 cycles of the triangle waveform across the full oscilloscope screen (10 divisions). To what time scale, in sec/div should the scopes sweep rate be set in order to see this? (2 pts)

$50Hz \Rightarrow T = 20ms$        $20ms \times 5 = 100ms$

$\frac{100ms}{10div} = \underline{\underline{10ms/div}}$

4) To simulate the scope's screen above in PSpice, what type of analysis is would be done on the schematic? Circle one of the following: (2 pts)

Time Domain (Transient) DC Sweep AC Sweep Bias Point

5) If the input to the circuit is changed to a sine wave, what type of analysis would be useful for determining when the output amplitude drops to half that of the input amplitude? Circle one of the following: (2 pts)

Time Domain (Transient) DC Sweep AC Sweep Bias Point

6) Two  $\frac{1}{8}$  W  $1\text{k}\Omega$  resistors are in parallel. What is the maximum voltage that can be applied across the pair without exceeding the power rating of the devices? (2 pts)

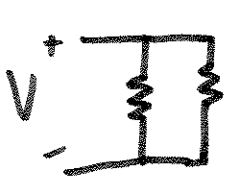

$$P = \frac{V^2}{R}$$

$$V = \sqrt{P \cdot R} = \sqrt{\frac{1}{8} \cdot 1\text{k}} = \underline{\underline{11.2\text{V}}}$$

7) If the two resistors in 6) are reconfigured in series, what is the maximum voltage that can be applied across the 2 series resistors without exceeding the power rating of the devices? (2 pts)



$$V = 2 \times V_6 = 2 \times 11.2\text{V} = \underline{\underline{22.4\text{V}}}$$

$$V = \sqrt{2 \cdot \frac{1}{8} \cdot 2(1\text{k})} = \underline{\underline{22.4\text{V}}}$$

8) What would be the color code of the equivalent resistance in 7) (assuming nominal 10% tolerance resistors)? (2 pts)

$$R_{EQ} = 500\Omega \Rightarrow \text{GREEN BLACK BROWN SILVER}$$