

Quiz 4a

1. **Logic Gates** You should recognize the logic gates in the figure below as those used in part of Experiment 10. If you performed the same kind of experiment as you did when you tested the gates on the protoboard, which of the following **three** figures is correct for the inputs shown? The digital clock represents the function generator and the other inputs are DC values obtained by connecting to the ground and V_{CC} rails on the protoboard.

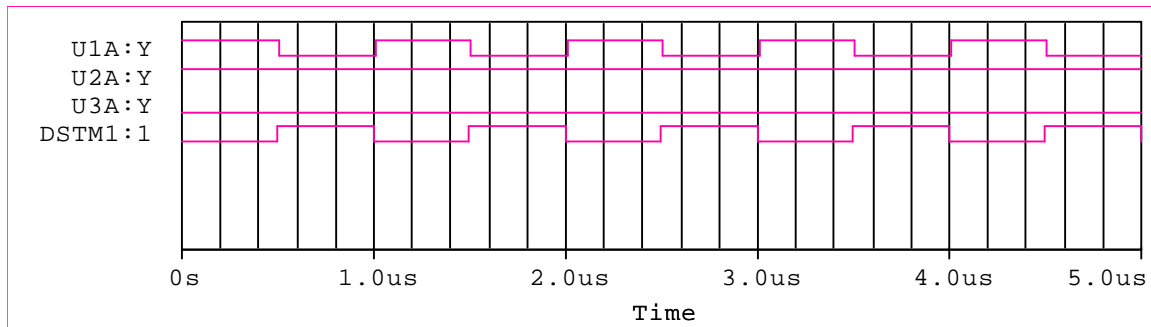

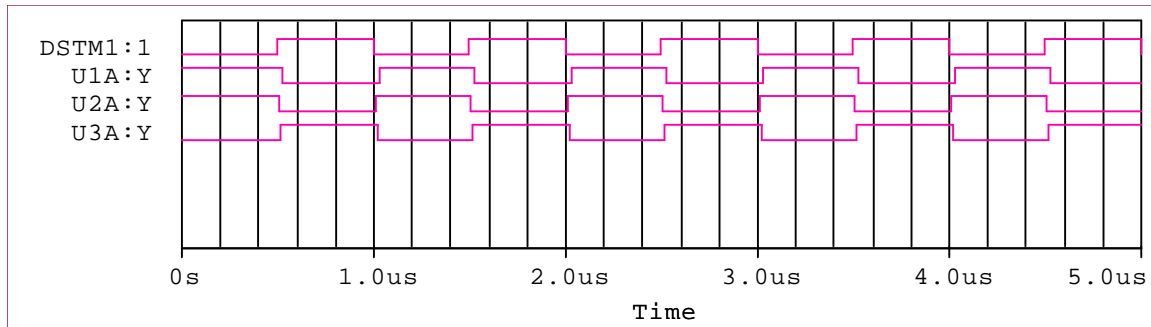
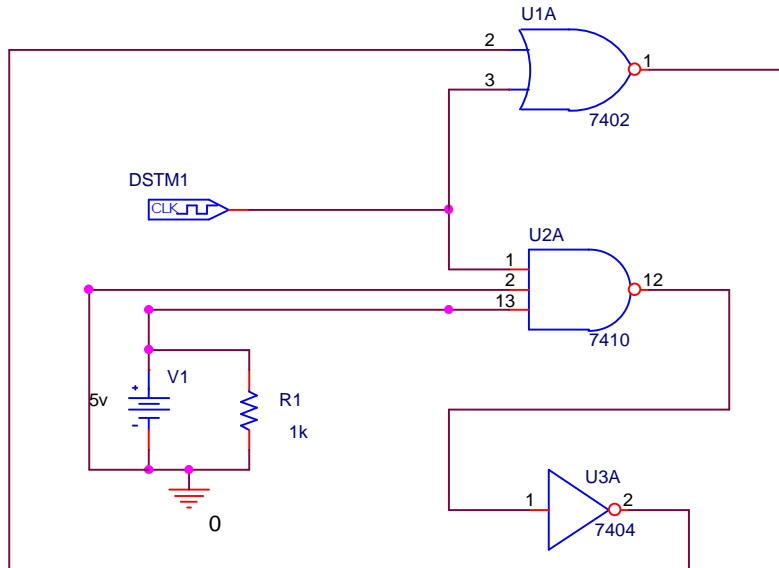
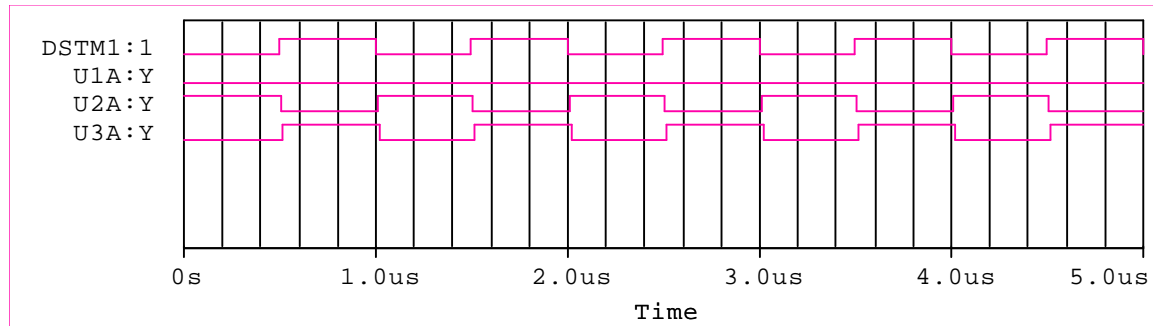

2. Digital-to-Analog Converter

The configuration of op-amps and resistors shown below can produce an analog output voltage (across the last 100k resistor on the right) equal to the binary word ABCD input at the left. Assume that you are working with TTL devices, so the voltage levels for ones and zeros are TTL levels (0V and 5V). Select values for R1, R2, R3, and R4 so that the output voltage will be the decimal equivalent of ABCD, for any choice of ABCD.

R1 = R2 = R3 = R4 =

Your choices of resistors should work for any number, but specifically show that your values work for the two binary numbers ABCD = 0110 and ABCD = 1001.

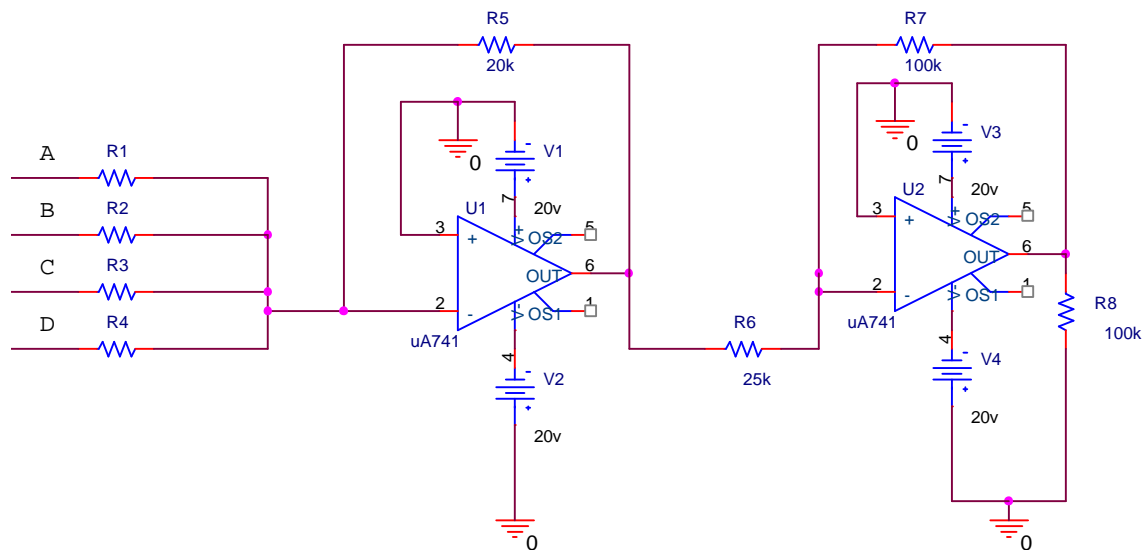

3. Combinational Logic

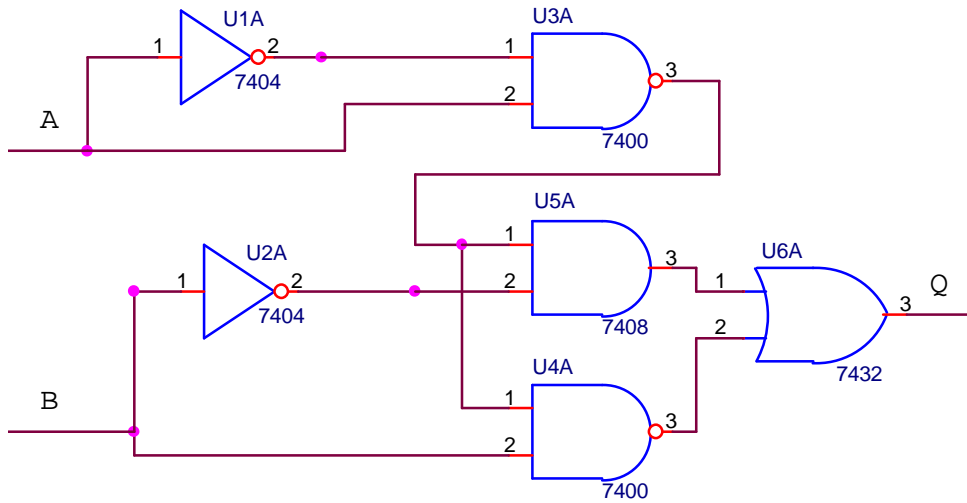

Which of the following truth tables is correct for this circuit?

A	B	Q
0	0	1
0	1	0
1	0	1
1	1	0

A	B	Q
0	0	1
0	1	1
1	0	1
1	1	1

A	B	Q
0	0	1
0	1	1
1	0	1
1	1	0

A	B	Q
0	0	0
0	1	0
1	0	0
1	1	0

A	B	Q
0	0	0
0	1	0
1	0	0
1	1	1

A	B	Q
0	0	1
0	1	1
1	0	0
1	1	1

A	B	Q
0	0	0
0	1	1
1	0	0
1	1	1

A	B	Q
0	0	1
0	1	0
1	0	1
1	1	1

4. NAND Gate Circuits

It is possible to configure all standard gates using just NAND gates. The figure below shows one such combination of NANDs. There are six voltages displayed on the transient voltage plot below. Identify which signal goes with which location. See if you can identify what the overall circuit is equivalent to. (You might want to construct the truth table for this purpose.) Remember that each standard gate comes in two forms, one that performs a particular logical function and one that performs the complement of (or NOT the) function.

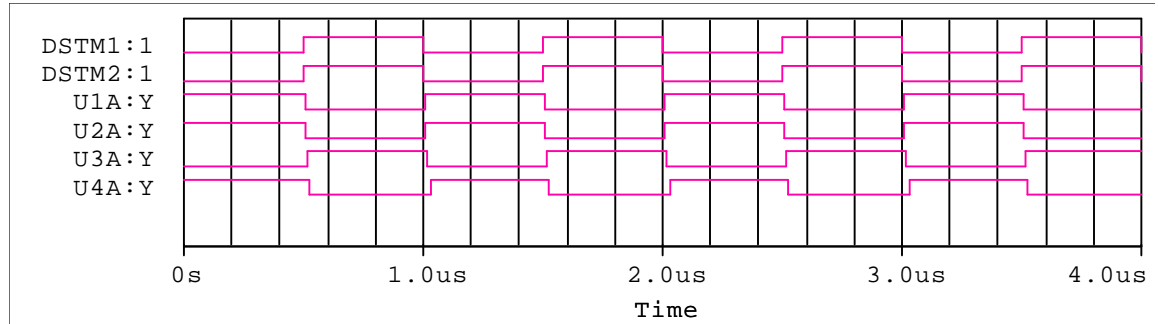
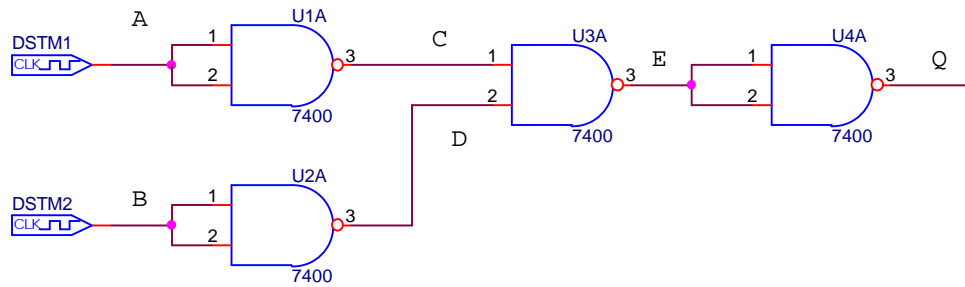

5. Transistor Switch – Relay Circuit

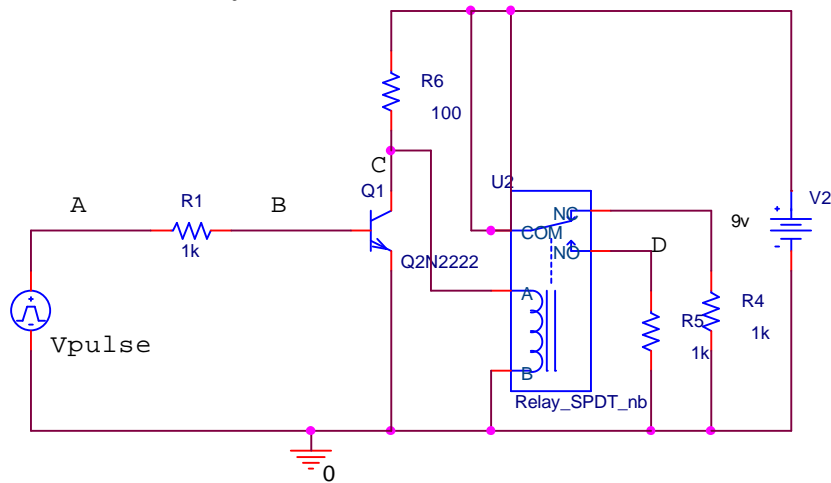

In the circuit above, the voltage source Vpulse puts out a sequence of pulses and the voltages at the source and three other points are monitored (marked A, B, C and D). You will note that this circuit is like the one we used in Exp 10 and in the Clapper project. The relay model used by PSpice (which gives switch times, circuit parameters, etc.) is listed below:

```
X_U2      N00064 0 N00350 N00343 N00087 Relay_Spdt_Bhv PARAMS:
+ T_make=20m
+ T_break=10m
+ I_pull=35ma
+ I_drop=25ma
+ R_coil=100
+ L_coil=5mH
+ R_open=100MEG
+ R_close=.05
```

Using this information and the overall circuit diagram, identify which of the following plots goes with this circuit?

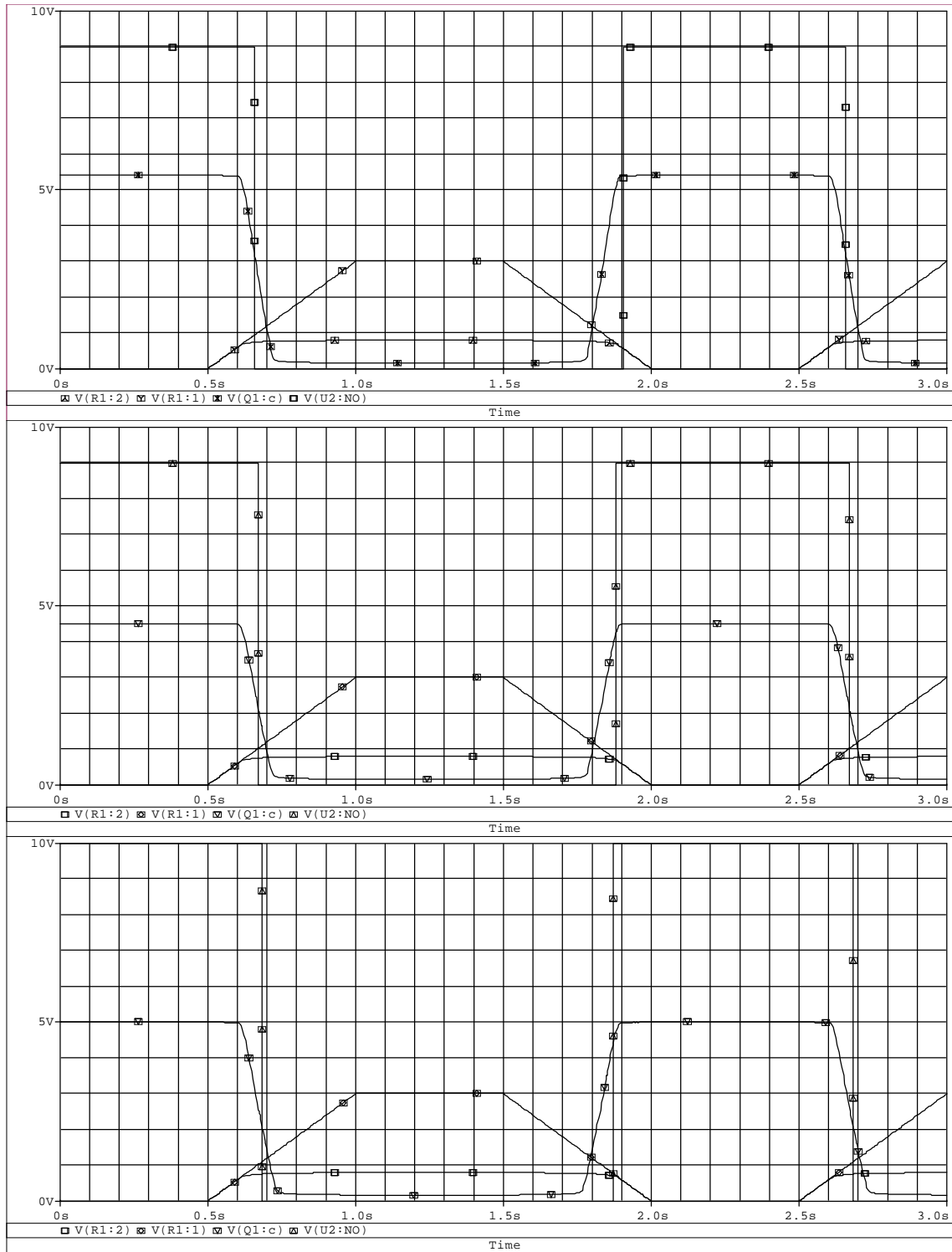

ENGR-4300
Name _____

Electronic Instrumentation

Fall 2000
Section _____