

Homework #3
Diode Rectifiers

Due: Monday, October 15th

Below are two diode circuit configurations and two figures showing the input and ideal output voltages for these circuits. The top configuration, the full-wave rectifier, is the most common circuit used to convert AC voltages (like from 60Hz power lines) to a nominal DC voltage.

Full-Wave Rectifier

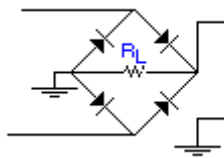

Input Voltage

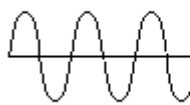

Output Voltage

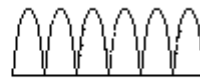

Half-Wave Rectifier

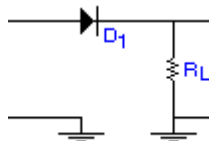

Input Voltage

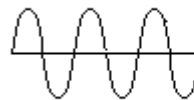

Output Voltage



a) Assuming that the diodes are ideal, draw both circuits for a positive and a negative V_{in} . i.e. replace the diodes with their on/off equivalents (short/open circuits).

In practice the diodes are not ideal, thus we obtain a slightly different output response. The following two rectifier circuits were analyzed using Pspice, using 1N4148 diodes.

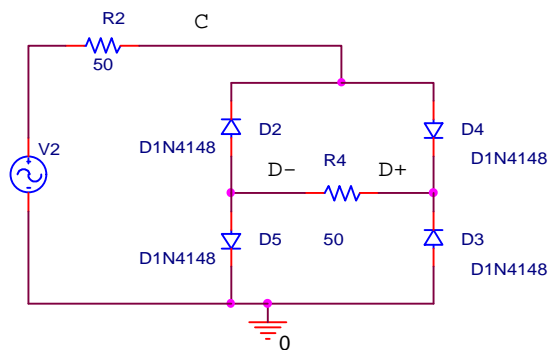
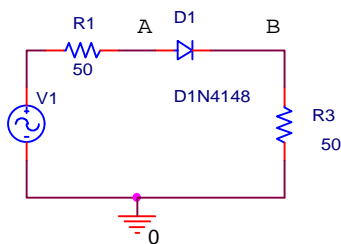

Shown below is a Probe plot for these two circuits showing the four voltages at the points marked A, B, C and D+/D-, where D is the differential voltage across the resistor R4.

b) Label which voltage trace goes with which point. Explain why each of these voltage plots looks the way they do when we use real diodes. In other words, explain the difference between the simulation results with the results with ideal diode assumption.

For reference purposes, the voltage sources used have an amplitude of 5V and a frequency of 1kHz.

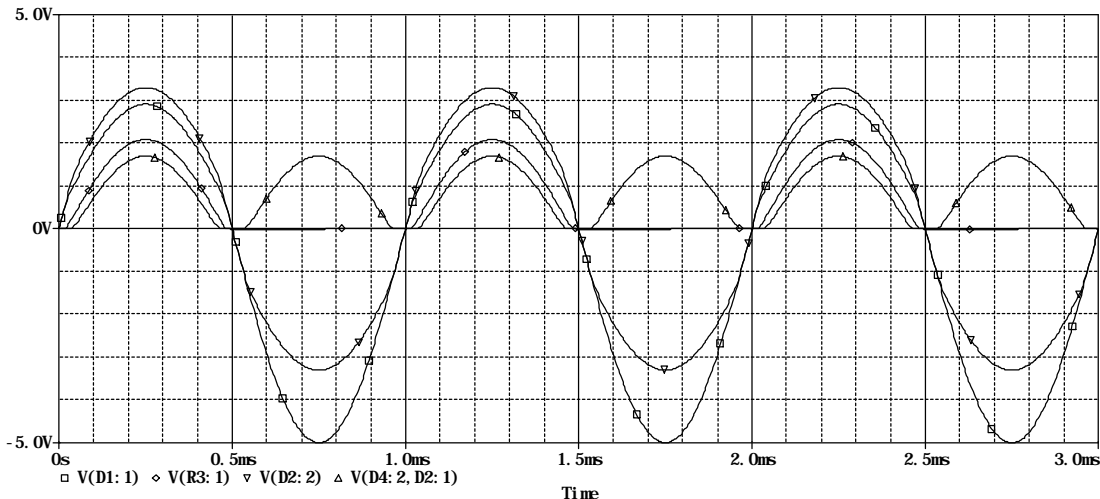

We can smooth out the output for these two standard rectifiers by placing a capacitor across each load resistor.

c) Where should we place the smoothing capacitor?

If we choose the standard capacitor value of 33 μ F, the voltage traces shown above will change to the following:

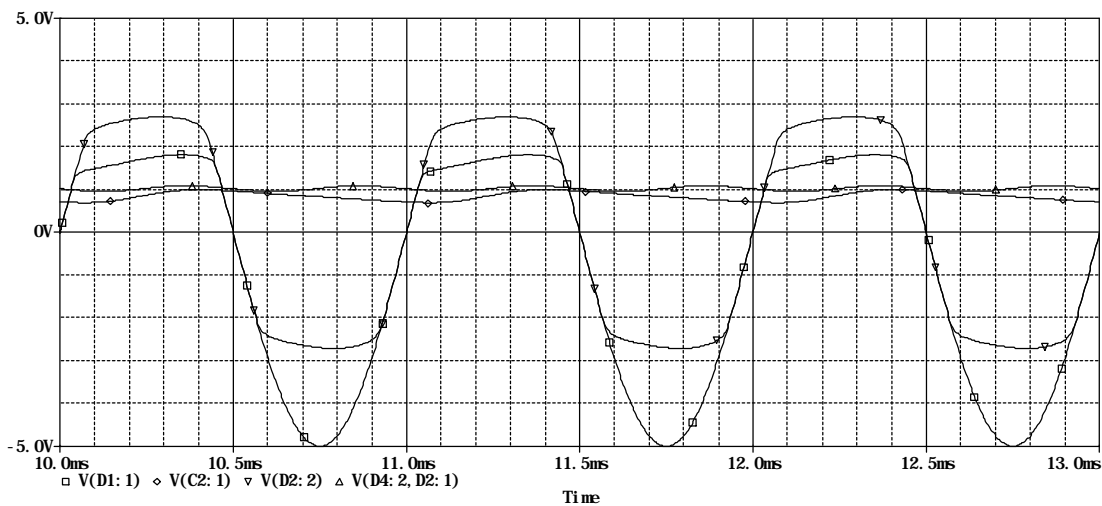

d) Identify which trace goes with each of the four points marked on the circuits.

Note that whenever the diodes feeding current to the load are on, the input voltage from the voltage source is modified. You should have seen this same effect in Experiment 6.

e) Explain why this happens.