

**Homework #5**  
**Number Systems, Boolean Algebra and Logic Gates**  
*Due: 4 December*

1. Number Systems: Convert the decimal numbers to binary and vice-versa (do not look them up in the table.):

Binary	Decimal
0101	
1001	
	6
	11

2. Boolean Algebra: Determine which boolean operation is represented by the following table:

B	A	Result
0	0	0
0	1	1
1	0	1
1	1	0

3. Logic Gates: What kind of logic gate is each of these devices?:

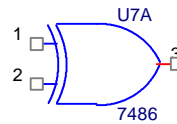
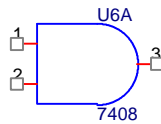
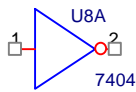
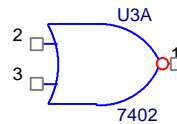
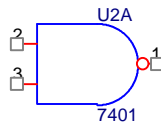
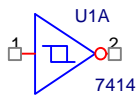

4. Boolean Algebra: Draw the circuit for this Boolean expression

$$Y = \overline{\left( (A + \overline{B})(C + B) \right)}$$

5. Fill in the truth table for the circuit below.

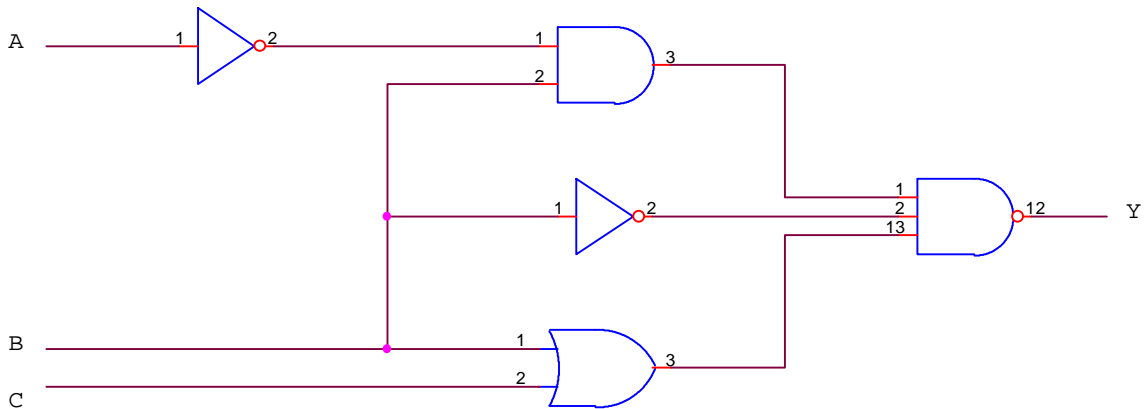

C	B	A	Y
0	0	0	
0	0	1	
0	1	0	
0	1	1	
1	0	0	
1	0	1	
1	1	0	
1	1	1	

Some reference materials:

<http://www.ied.edu.hk/has/phys/de/de-ba.htm>

<http://www.dgp.utoronto.ca/people/van/courses/csc258/bool.html>

8. Design a monostable multivibrator that outputs a single 5msec pulse using a 555 timer. Perform a PSpice simulation of your circuit to show that it works. Some useful links follow.

<http://www.uoguelph.ca/~antoon/circ/monovib.htm>

<http://www.hobby-electronics.com/MonostableMultivibrator.htm>