

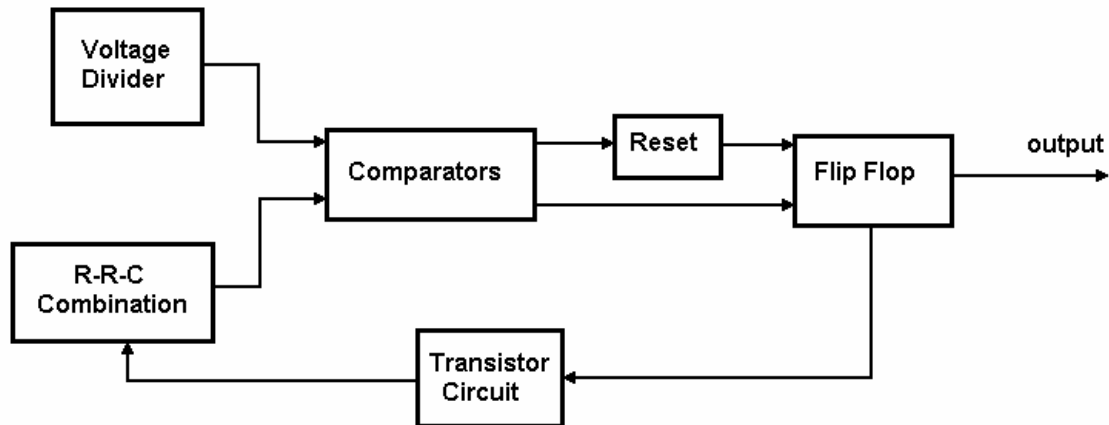

inside the 555-timer to create the desired output. Before you start building, identify the parts of the circuit in the animation that correspond to each of the blocks in the diagram.



Block Diagram of Astable Multivibrator

Figure 2

Watch the animation to get an idea of how an astable multivibrator works. The rate of the output pulses is determined by the rate at which the capacitor,  $C_1$ , charges and discharges. The middle trace of the tutorial shows the voltage across the capacitor. When the voltage across the capacitor exceeds  $2/3$  of the source voltage,  $V_{cc}$ , the output of comparator 1 goes high and causes the flip flop to set. The output flip flop will go high, call this  $Q$ . The output of the 555 is the inverse of the output of the flip flop, so call this  $\bar{Q}$ . **Important point – for this model, the  $\bar{Q}$  of the flip flop is the output of the 555 timer.** When  $Q$  goes high, the discharge transistor switch closes, and pin 7 is grounded. The capacitor begins to discharge through this new path to ground. When the capacitor discharges down to  $1/3$  of the source voltage, the output of comparator 2 goes high and causes the flip flop to reset. The output at  $\bar{Q}$  goes high (and  $Q$  goes low). When  $Q$  goes low, the discharge transistor switch opens, the path to ground is broken, and the capacitor begins to charge again.

Before you can fully understand the function of the multivibrator, you must understand the components you are using to build it. The animation shows the following components: an RC circuit, a voltage divider, two comparators, a flip flop, a transistor, and an inverting amplifier. You have learned what these components are and how they behave during this course. Your circuit is slightly different, so be careful when writing the report. In your write up, you will need to describe how each part of your circuit functions in enough detail to show that you understand the details of what is happening in the circuit. You will also need to explain how the function of each of these components relates to the function of the astable multivibrator. For instance, the following discussion describes the transistor and how it functions in the circuit:

*A transistor is an electronically controlled switch that will close the connection between the collector and the emitter when the difference between the base*

voltage and the emitter voltage ( $V_{BE}$ ) exceeds about 0.7V. In this circuit, the emitter voltage is ground (0V) and the base is connected to the output of a flip flop. The output of the transistor circuit is measured at the collector. This is the discharge pin of our flip flop model. When the flip flop outputs a logic low voltage (theoretically 0V), the base voltage of the transistor does not exceed 0.7V above the emitter voltage ( $V_{BE} = 0V - 0V$ ) and the switch is open. In this instance, the discharge pin of our timer model is not connected. When the flip flop outputs a logic high voltage (theoretically 5V), the difference between the base voltage and the emitter voltage ( $V_{BE} = 5V - 0V$ ) is greater than 0.7V and the switch closes. This grounds the collector and forces the discharge pin to 0V. It is through this path to ground that the capacitor in the R-R-C combination discharges. (Hence, the name of the pin.)

When you describe each device and how it functions, you will want to discuss in your own words how the device works in general and the voltage levels you should see in theory. You will need to relate the behavior of the device (and its input and output voltages) to the series of events that make the multivibrator function.

Another important aspect of this project is the equations that you use to calculate the on and off times of the output pulses. The R-R-C combination is directly related to the timing of the pulses generated by the multivibrator. You have been given two equations that can be used to find the rate and duty cycle of the pulses this circuit generates:

$$T_{on} = 0.693(Ra + Rb)C \quad \text{and} \quad T_{off} = 0.693(Rb)C$$

Where do these equations come from? We know that the charge/discharge time of a capacitor is determined using the time constant,  $\tau = RC$  where C is the capacitance of the capacitor and R is the total resistance that the capacitor is charging or discharging through. For the on cycle, the capacitor charges through Ra and Rb. For the off cycle, the capacitor discharges through Rb only. Therefore,

$$T_{on} = 0.693\tau_{charge} \quad \text{and} \quad T_{off} = 0.693\tau_{discharge}$$

the constant, 0.693, is related to the portion of the charge cycle over which the capacitor charges and discharges. We can find this using the charge and discharge equations.

The equation for a capacitor charging is  $V_C = V_0\left(1 - e^{-t/\tau}\right)$ . (equ 1)

The equation for the discharge is  $V_C = V_0\left(e^{-t/\tau}\right)$ . (equ 2)

We can use these equations to determine how much voltage is on the capacitor at any given time. For instance, at  $t=0$ , an uncharged capacitor will start with an initial change of

$V_C = V_0(1 - e^0) = 0V$  and a fully charged capacitor will have an initial voltage of  $V_C = V_0(e^0) = V_0$ . If the capacitor is charging up from 0 volts, we can find how much time it will take to gain 1/3 of its total charge, as follows:

$$\frac{1}{3}V_0 = V_0\left(1 - e^{-t/\tau}\right) \quad \ln\left(1 - \frac{1}{3}\right) = -\frac{t}{\tau} \quad t = 0.405465\tau \text{ sec}$$

The capacitor in the astable multivibrator charges and discharges *between* 2/3 and 1/3 of the source voltage. How could you use the charge and discharge equations to determine what portion of the charge cycle this is? [Hint: To get the time between 1/3 and 2/3, subtract the time to reach 1/3 from the time to reach 2/3.] How is this number related to the equations for the on-time and off-time of the astable multivibrator? You will need to answer these questions in the background portion of your report. You will also need to calculate the on and off times you should expect to get out of the R-R-C combination in the circuit you will be building (shown in figure 3).

## B. Initial Design

For the initial design of this project, you model the circuit in figure 3 in PSpice, and build the circuit in figure 5 on the protoboard. These are nearly the same circuit. The demo version of Capture and PSpice we are using doesn't have an LED model and won't allow the use of 2 op-amps and 2 logic gates in one simulation. That is why you model a somewhat different circuit. You will carefully examine the behavior of the circuit and the PSpice model. You will compare the actual circuit to the model by looking at the general behavior of the circuit at different points. You will identify and compare specific voltage and time features of the signals. You will also compare the features of your signals to what you would expect to see based on the theory.

You will note that the components that we use in the circuit are all devices we have covered. In order to use components that are familiar to you (and that you have in your kits), we have taken some liberties with the internal operation of the 555-timer. The flip-flop in the animation will be built using two-input NOR gates, 74LS02 available from the TAs. The circuit you will build doesn't include the reset pin of the 555 timer. Extra credit is offered to teams that modify the circuit to include this pin. PSpice also adds a few of its own idiosyncrasies that are discussed in the following section.

### B1. PSpice Implementation

Wire the circuit in figure 3 in PSpice. Note that the circuit has the same basic components as the 555 timer in the animation. Where is the Ra-Rb-C combination? What should the on and off times be when you run your simulation? You should be able to identify the components in the circuit that correspond to the blocks in the block diagram in figure 2.

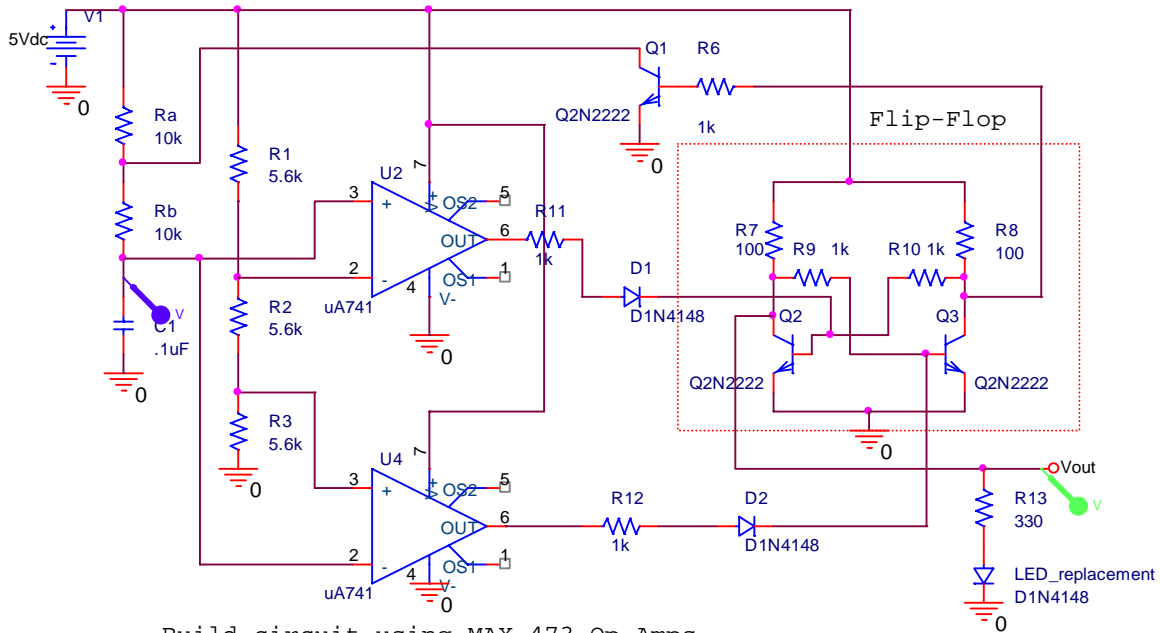

Build circuit using MAX 473 Op-Amps

Figure 3

Note 1: Modeling the circuit that you will build exceeds the allowed size in the demo version of Capture.

Note 2: The demo version doesn't have an LED, a 1N4148 diode is used to take the place of the LED

Note 3: Run a transient analysis for 10 milliseconds. Skip the initial bias point calculations.

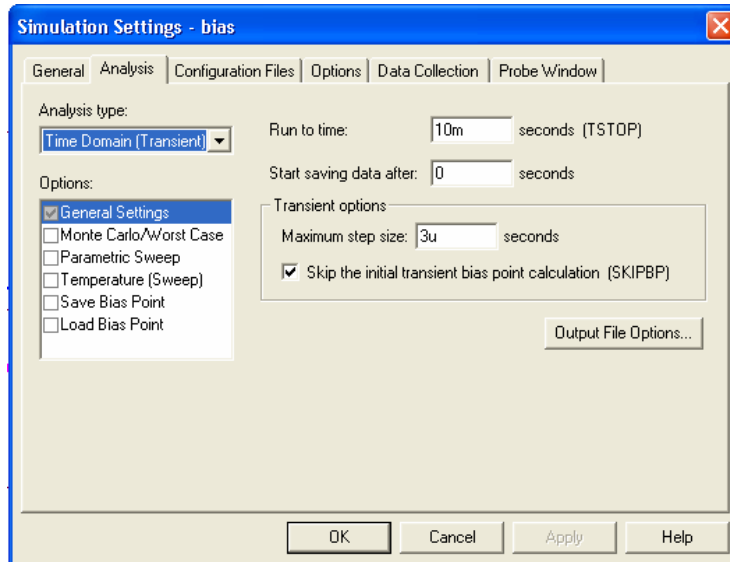

Figure 4, Check box to “Skip the initial transient bias point calculations”

**B1-a PSpice Issues**

*Component Substitutions* The student version of PSpice doesn't have a model for an LED. We will use a D1N4148 diode (EVAL library) to model the LED. See note 2 on the diagram in figure 3.

**B1-b Running the PSpice Simulation**

Run a simulation for 10ms using a maximum step size of 5us.

*Verification of output:* When you get the simulation working, verify that the output is correct. Determine which nodes in the circuit represent the Threshold, Trigger, Discharge and Output. Do the signals at the Threshold, Trigger, Discharge and Output look like those of the astable multivibrator you wired in experiment 7? Is the capacitor charging and discharging between  $1/3 V_{cc}$  and  $2/3 V_{cc}$ ? Are  $T_{ON}$  and  $T_{OFF}$  close to the values you calculated with the equations? DO NOT use the first cycle of the output to calculate your times.

*Choosing points of interest:* Your PSpice circuit will have many points that are of interest to you. If you display them at the same time, it will be very hard to determine what is happening in the circuit. Therefore, once you have the circuit functioning, generate a PSpice plot for each of the situations listed below. Most of these devices have more than one input or output, so all of these plots will have more than two signals. You do not need to show power connections to the chips. USE THE CURSORS to display time and voltage quantities on the plots. (See details below.)

- Inputs to Threshold comparator and output from Threshold comparator
- Inputs to Trigger comparator and output from Trigger comparator
- Inputs to flip flop and outputs from flip flop at Q and Qbar
- Input to transistor circuit at Q, signal at the base of the transistor, and output from transistor circuit at the collector.
- The behavior of the multivibrator from the outside. (Look at the locations corresponding to pins 2, 3, 6 and 7 of the 555-timer.)

USE THE CURSORS to mark important features of the output. What are the on and off times? Between what voltages does the capacitor charge and discharge? What levels do the different devices output for "high" and "low"? What is the maximum voltage at the base of the transistor? You will be comparing these to the values you get using your actual circuit. Make sure you have the following quantities marked on at least one plot.

Write the values in this chart:

<i>Mark the following</i>	<i>voltage or time value</i>
on-time	
off-time	
period	
maximum voltage of C1	
minimum voltage on C1 (after 1 <sup>st</sup> cycle)	
“low” output voltage at Qbar	
“high” output voltage at Qbar	
maximum voltage at node between Ra and Rb	
minimum voltage at node between Ra and Rb	
maximum voltage at base of transistor	
minimum voltage at base of transistor	

**B2. Building the Circuit**

Now you are ready to build the circuit on your protoboard. Use figure 5 as your guide, but keep in mind that we made some substitutions in PSpice (See section B1-a).

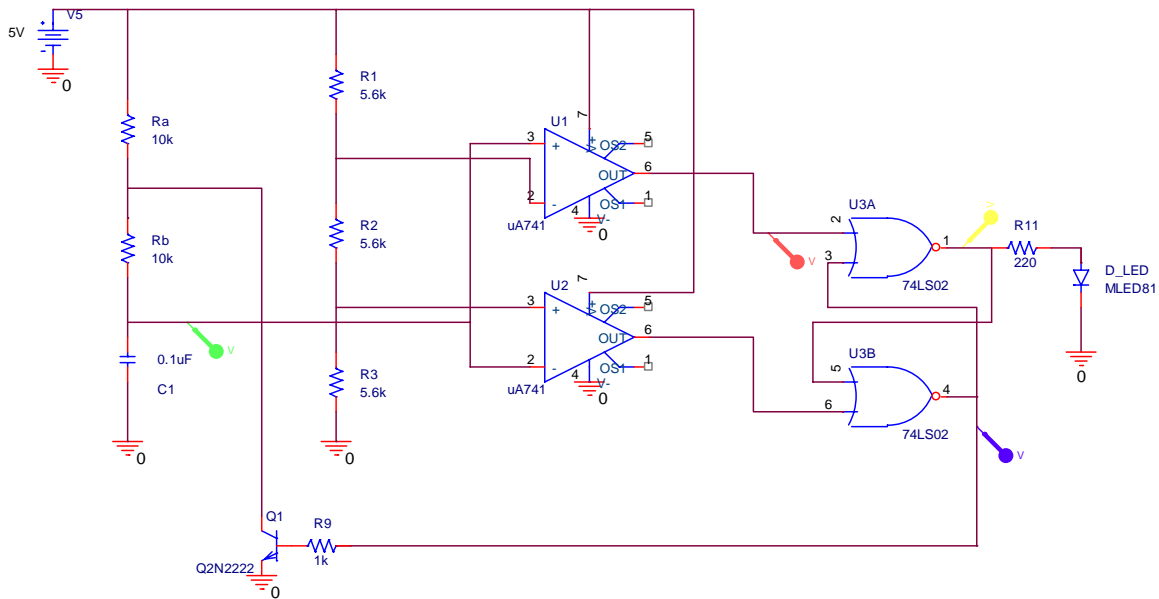
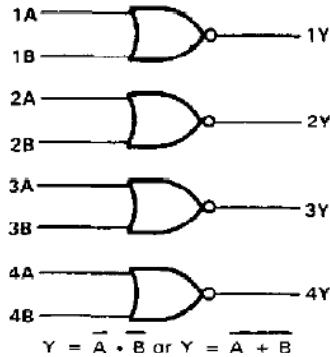

**Figure 5, Build using MAX473 Op-Amps. Remember that the 74LS02 requires power and ground.**

**B2-a Circuit Considerations**

*Flip-Flop:* The 74LS02 has 4 dual input NAND gates, see figure 6. Confirm that the using two of these gates in this circuit will result in an SR Flip-flop. Do this by creating a truth table with pins 2 and 6 as the inputs and 1 and 4 as the outputs.

## logic diagram (positive logic)



SN5402 . . . J PACKAGE

SN54LS02, SN54S02 . . . J OR W PACKAGE

SN7402 . . . N PACKAGE

SN74LS02, SN74S02 . . . D OR N PACKAGE

(TOP VIEW)

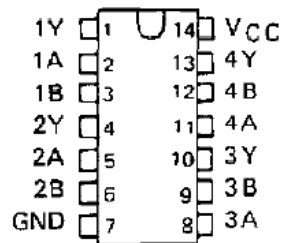

Figure 6

*by-pass capacitor:* PSpice has no noise. In your real circuit, you will want to add a 0.1 $\mu$ F by-pass capacitor between the source voltage and ground.

### B2-b Debugging the Circuit

This circuit is tricky to debug because it cycles back upon itself. You also will not be able to see anything happening without the scope. With the 0.1 $\mu$ F capacitor, the LED will appear to be always lit, as it is blinking too fast for you to see. Follow this procedure:

- Replace the 0.1 $\mu$ F capacitor with a larger capacitor, like 100 $\mu$ F. If the circuit is working correctly, you should see the LED blinking now. It is not a bad idea to go through this procedure even if your circuit seems to work. It will help you gain a better understanding of what is going on.
- If the LED does not blink, disconnect the wire between the transistor and the two 10k resistors. This will break the feedback loop and allow you to control the circuit manually in order to debug it.
- The idea is to look at how the circuit is behaving as the 100 $\mu$ F capacitor charges and discharges. Attach the scope and look at the signal across the capacitor. You are only interested in the DC level of the signal, so it should look like a line (probably at 5V). Take a long wire and attach it to the non-grounded side of the



- capacitor. Attach the other end of the wire to ground. The capacitor will immediately discharge down to zero volts. Now disconnect the wire from ground. You should see the DC signal from the capacitor slowly rising on the scope. This is the capacitor charging. Since the feedback is not connected, the capacitor should charge all the way up to 5V and stop.
- Now that you can see the input, you can look at various points in the circuit to find out if they are functioning as expected. Leave one scope channel on the capacitor voltage and put the other scope channel at the output of the threshold comparator, U1 in the schematic. This comparator should switch states when the voltage across the capacitor reaches  $2/3 V_{cc}$ . Briefly ground the capacitor and then watch the signal rise. Does the comparator switch at the right time? If it does, then this part of the circuit is working. If not, then check your wiring.
  - Now you can look at the signals at the rest of the points in the same way. Try looking at the output of the trigger comparator, U2, the NOR gates, and the transistor. These should all switch at some point as the capacitor charges. If the switch does not occur, check your wiring and try adjusting the pot. When you know all of these are switching properly, reconnect the wire between the transistor and the two 10k resistors. The circuit should work.
  - Remember to replace the 100uF capacitor with a 0.1uF capacitor before you take your data.

### B2-c Observing the Behavior of the Circuit

Once your circuit is functioning, you should determine if it is working correctly as an astable multivibrator.

*Verification of output:* Use the scope to look at the signals at various points in the circuit. (Note that you should now be using the .1uF capacitor and looking at the shape of the signals and not just the DC levels you used for debugging.) Use your PSpice output to verify which signals should be high or low at which times. You can also use the scope to observe signals that you should recognize from the animation and experiment 7. Is the output a string of pulses? Does the capacitor charge and discharge? Once you determine that the circuit is basically correct, consider the values of the signals you are observing. Is the capacitor charging and discharging between  $1/3V_{cc}$  and  $2/3 V_{cc}$ ? Are  $T_{ON}$  and  $T_{OFF}$  close to the calculated values?

*Record the output of the circuit:* Now it is time to record the output of your circuit. Since there are only two scope channels, you won't be able to observe all the signals at the same time. USE THE CURSORS to display time and voltage quantities on the bottom of the plots. (See details below). Take pictures of the following signals:

- *Channel 1:* Voltage across capacitor  
*Channel 2:* Output from Threshold comparator
- *Channel 1:* Voltage across capacitor  
*Channel 2:* Output from Trigger comparator
- *Channel 1:* Output from Threshold comparator

- Channel 2:* Qbar of Flip-Flop, Pin 1 of 74LS02 in the schematic
- *Channel 1:* Output from Trigger comparator
  - Channel 2:* Q of Flip-Flop, Pin 4 of 74LS02 in the schematic
- *Channel 1:* Q of flip flop
  - Channel 2:* Output from transistor circuit (at collector)
- *Channel 1:* Voltage across capacitor
  - Channel 2:* Qbar of flip flop

USE THE CURSORS and the other voltage and time features of your scope to get actual voltage and time values. Make sure that you record these numbers and list them on the corresponding plots. Measure the +5V power, it may not be exactly 5V. What is the power supply voltage? What are the on and off times? Between what voltages does the capacitor charge and discharge? What levels do the different devices output for “high” and “low”? What is the maximum voltage at the base of the transistor? You will be comparing these to the values you found using PSpice. Make sure you have the following quantities displayed underneath the trace on at least one plot. Write the values in this chart:

<i>Mark the following</i>	<i>voltage or time value</i>
on-time	
off-time	
period	
maximum voltage across C1	
minimum voltage across C1	
“low” output voltage at Qbar	
“high” output voltage at Qbar	
maximum voltage at node between Ra and Rb	
minimum voltage at node between Ra and Rb	
maximum voltage at base of transistor	
minimum voltage at base of transistor	

### C. Final Design

In the final design of this circuit you will alter the inner workings of the 555 timer to make it change states by changing the resistor divider string. You will also determine the equations that now predict the behavior of the altered multivibrator and verify that your new circuit behaves as predicted by the altered equations.

#### C1. Alterations in PSpice

Replace R3, the bottom resistor in the divider string with a 1k $\Omega$  resistor. Alter the circuit in PSpice and verify that the alterations have worked. Since you already know that the circuit works, you need not take all the data again. Just generate a plot of the behavior of the modified multivibrator from the outside. (Look at the locations corresponding to pins 2, 3, 6 and 7 of the 555-timer.) USE THE CURSORS to mark important features of the

output. You will be comparing these to the values you get using your actual circuit. Fill in the following chart:

<i>Mark the following</i>	<i>voltage or time value</i>
on-time	
off-time	
period	
maximum voltage across C1	
minimum voltage across C1	
maximum voltage at node between Ra and Rb	
minimum voltage at node between Ra and Rb	

Find the new on and off times ( $T_{ON}$  and  $T_{OFF}$ ) for the multivibrator using the PSpice simulation. They should have changed because you are now using a different part of the capacitor charge cycle.

Use the charge equations for capacitors to find new equations for the on and off times of the circuit. Equations 1 and 2 in this project are special cases of the full capacitor equation, which is:

$$V_C(t) = V_{final} - (V_{final} - V_{initial})e^{-t/\tau} \quad (\text{equ 3})$$

Where:

$V_{final}$  is the voltage the capacitor would reach if the circuit doesn't switch. It is +5V if the capacitor is charging and 0V if the capacitor is discharging.

$V_{initial}$  is the voltage on the capacitor just after the circuit switched. In the case of parts A and B, this would be 3.3V at the start of a discharge and 1.7V at the start of a charge.

These are the switching voltages.

$\tau$  is the RC time constant. It is  $(R_a + R_b) \cdot C_1$  for the charge, and  $R_b \cdot C_1$  for the discharge.  $t$  in this equation starts at 0 at each switching point

You are now charging between two different voltages. What are they? You will have to find the on time and off time using equation 3. Compare them to the values you found in PSpice.

## C2. Circuit Changes

Modify the circuit on your protoboard in the same manner as you did the PSpice circuit. Take an image of the signal over the capacitor (pins 2 and 6) and the output of the multivibrator (pin 3). Also take an image of the signal over the capacitor and the signal between Ra and Rb. USE THE CURSORS and the other voltage and time features of your scope to get actual voltage and time values. Make sure these numbers are recorded and are added to your data plots. You will be comparing these to the values you found using PSpice. Fill in the following chart:

<i>Mark the following</i>	<i>voltage or time value</i>
on-time	

off-time	
period	
maximum voltage across C1	
minimum voltage across C1	
maximum voltage at node between Ra and Rb	
minimum voltage at node between Ra and Rb	

Determine the on and off time ( $T_{ON}$  and  $T_{OFF}$ ) of the output pulses. How do these compare to the PSpice times? ...to the times predicted by your new equations?

#### D. Extra Credit

A real 555 timer has a reset pin. For extra credit, modify your circuit to include this function. Do this to either the PSpice simulation or the protoboard version. Have a TA confirm that the reset function works, and that the 555 also still works.

If you have another idea for extra credit, discuss it with your professor.

#### E. Appendices

The following appendices summarize what you need to do, what the appendix of your report should contain, and what should be included in your report.

##### I: Task List

Create your own task list and include it in your report. You should base it on the task lists we have given you in the first two projects. YOU MUST include a task list in your report. If you found this list helpful while completing the first two projects, you may want to make it as you begin the project rather than at the end.

##### II: The Appendix of Your Report

The following list of items must be included in the appendix of your report, numbered and ordered as listed. This will help make sure that everyone includes everything that is required. In your report you should refer to each appendix specifically as needed to help illustrate your descriptions and conclusions. If you would like, you can include a second copy of what is in the appendix in order to better illustrate what you are trying to say, however, this is not necessary and cannot be used as a replacement for the contents of the appendix.

Appendix A: Task List

Appendix B: Background and Theory

1. Calculation of portion of charge time between  $1/3V_{cc}$  and  $2/3V_{cc}$ .
2. Calculation of on-time and off-time of circuit in figure 3.
3. References

## Appendix C: Initial Design -- PSpice

1. PSpice Plots (all clearly labeled)
  - Threshold comparator
  - Trigger comparator
  - flip flop (Q2 and Q3)
  - transistor discharge circuit (Q1)
  - multivibrator from the outside. (pins 2, 3, 6 and 7)
2. Any additional PSpice output you would like to include

## Appendix D: Initial Design -- Circuit

1. Mobile Studio Plots (all clearly labeled)
  - Threshold comparator
  - Trigger comparator
  - flip flop output and Threshold comparator
  - flip flop output and Trigger comparator
  - transistor
  - capacitor and output from flip flop
2. Any additional plots you would like to include

## Appendix E: Final Design

1. Circuit Diagram
2. Calculations
  - Calculation of threshold and trigger voltages.
  - Modified equations of multivibrator
  - Calculations of on-time and off-time of new circuit
3. PSpice plot of pins 2, 3, 6 and 7
4. Mobile Studio plots of capacitor voltage and output voltage
5. Mobile Studio plots of capacitor voltage and voltage at the node between Ra and Rb

**III: Your Group Report (70 points)**Introduction (4 points)

State the purpose of the project and name at least two things you have learned in the class that are relevant.

Background and Theory (15 points)

Describe how each of the individual circuit components that you used to build the circuit works. The animation shows the basic components: an RC circuit, a voltage divider, two comparators, a flip flop, and a transistor. Describe the behavior of each. Concentrate on the features of the components that are most relevant to the way they behave in the multivibrator circuit. For example, you don't need to talk about how to combine capacitors in series because this is not relevant to this circuit. However, the rate at which capacitors charge and discharge in RC circuits is important in this circuit and should be discussed. Site any references you use in appendix B of your report.

After you have discussed the operation of each of the pieces, consider the multivibrator as a whole. How does it work? How do the pieces work together to create the output? Be specific.

Also include a discussion of the equations that we use to find the on and off times for the multivibrator. Where do they come from? Why do they make sense? What should the on and off times of the circuit you built (figure 3) be? Include your calculations in appendix B.

Initial Design (22 points)

Include a discussion of the output from the initial design in PSpice. Include the plots in appendix C. Describe how you know that the plots that you generated are correct. Don't forget to discuss the voltage levels you marked on the plots. Also, compare the on and off times you read off the plots to the ones you calculated.

Include information about the implementation of the initial design on your protoboard. Discuss how you wired and debugged your circuit. Include the plots created for appendix D. Demonstrate that the data that you took makes sense based on the behavior of the circuit. Discuss the voltage levels you recorded using the scope features. Compare the on and off times you found with the ones you calculated.

Compare the voltage levels you found in PSpice to the voltage levels in your circuit. Also compare the on and off times. How close are they to each other? How close are they to the theoretical values you expect? For some of the voltage signals, being close to the theoretical value is important to the function of the circuit, for others, it is not. Which levels have more tolerance, the analog voltage levels or the digital voltage levels? Which of the signals you recorded would you consider to be analog and which to be digital?

Final Design (15 points)

Include a circuit diagram of your final design in appendix E. Include the calculations you used to determine the new equations in appendix E. Summarize the results of these calculations.

Discuss the output traces you found using PSpice. Include the plot in appendix E. How do you know that the plots that you generated are correct? Discuss the voltage levels you marked on the plots. Compare the on and off times you read off the plots to the ones you calculated.

Discuss the voltage levels of the circuit on the protoboard and the voltages and time you recorded using the scope features. Compare the trigger and threshold voltages and the on and off times you found with the ones you calculated.

Compare the voltage levels you found in PSpice to the voltage levels in your circuit. Also compare the on and off times. Compare these to the theory. For this part, you only need to consider levels and timing that were affected by the change in design.

#### Conclusion (7 points)

Did you build an astable multivibrator? How do your output plots and pictures demonstrate this?

Present a summary of the similarities and differences between the PSpice plots and the data from the circuits that you built. How well did PSpice predict the voltage levels you observed in the circuit? Were the values close to those you expected based on the theoretical behavior of the devices?

Discuss the similarities and differences between the on and off times of your initial design found using the equations, PSpice, and the scope. Discuss the similarities and differences between the on and off times of your final design found using the equations, PSpice, and the scope.

This section should also include a discussion of sources of error and some basic conclusions about what you learned.

#### Personal Responsibilities (4 points)

\* How were the tasks divided between group members?

#### Appendices (3 points)

\* See appendix II of this handout

#### Extra Credit (0-5 points)

\* Include any details that you would like to include about anything you tried above and beyond the basics of the project.

Your grade will also include a general assessment of project understanding and quality worth up to 10 points. You do not need to write a general assessment.

**Total: 70 points for project report**  
**+ 10 points for general assessment of report**  
**+ 20 points for attendance**  
**= 100 points**

**Attendance (20 possible points)**

**3 classes (20 points) 2 classes (10 points) 1 class (0 points)**  
**Minus 5 points for each late.**

*No attendance at all = No grade for project.*